

RADIO BROADCAST

DECEMBER, 1928

WILLIS KINGSLEY WING, Editor

KEITH HENNEY
Director of the Laboratory

EDGAR H. FELIX
Contributing Editor

HOWARD E. RHODES
Technical Editor

Vol. XIV. No. 2

CONTENTS

Cover Design	From a Design by Harvey Hopkins Dunn	
Frontispiece	Old Sayville Station Returns to Limelight	84
Quartz Crystals	R. C. Hitchcock	85
Phonograph-Radio Amplifiers	Howard E. Rhodes	88
The March of Radio	An Editorial Interpretation	91
Radio, the Corner Stone of the Amusement Industries	With the Broadcasting Stations	
Wgy Protests Allocation Plan	The Progress of Aircraft Radio	
The 300-Mile Chain Regulation	Radio Abroad	
The Fight for Short Wavelengths	The Visual Broadcasting Field	
	News of the Radio Industry	
The "Skyscraper" Screen-Grid Receiver	Clifford Denton	95
"Strays" from the Laboratory	Keith Henney	97
Accuracy of "Slide-Back" Voltmeters	Data on Underground Aerials	
Hum in the "Lab." Circuit Receiver	Type 112 Tubes in First Audio Stage	
A Test Set for the Radio Service Man	B. B. Alcorn	99
The Service Man's Corner		101
As the Broadcaster Sees It	Carl Dreher	102
Information on Sound Motion Pictures	Broadcast Standardization	
Some Experiments with Band-Pass Filters	Kendall Clough	104
"Radio Broadcast's" Home Study Sheets		107
No. 11. Resonance in Radio Circuits—Part I	No. 12. Resonance in Radio Circuits—Part II	
Loud Speakers—A Debate		109
Removing Nonsense from Short-Wave Transmission	Robert S. Kruse	111
"Our Readers Suggest—"		114
An A.C. Screen-Grid Booster	Push-Pull with Standard Transformers	
Work Table Clamp	Home-Made Soldering Lug	
The New A.C. Screen-Grid Browning Drake Receiver	Glen H. Browning	115
Book Reviews	Howard E. Rhodes	116-125
An A.C. Band-Pass Screen-Grid Receiver—The Master "Hi-Q 29"	William E. Barton	117
New High-Voltage Metallic Rectifiers for B-Power Units	J. George Uzmann	120
"Radio Broadcast's" Service Data Sheets		121
No. 13. The A.C.-66 Dayton Receiver	No. 14. The Fada Models 50, 70, 71 and 72	
Problems in Synchronizing Television Receiving Discs	Boyd Phelps	123
The "Chronophase" for A.C. Tubes	Bert E. Smith	126
New Apparatus and Their Applications		127
Manufacturers' Booklets		128
"Radio Broadcast's" Laboratory Information Sheets		130
No. 241. Supplying Power Devices from 220 Volts A.C.	No. 246. Power Output Characteristics of Tubes	
No. 242. Resistance-Coupled Amplifiers	No. 247. Television	
No. 243. Resistance-Coupled Amplifiers	No. 248. Frequency Characteristics of Television Amplifiers	
No. 244. Alternating-Current Ratings		
No. 245. Power Output		
Letters from Readers		137
Short-Wave Stations		141

The contents of this magazine is indexed in *The Readers' Guide to Periodical Literature*, which is on file at all public libraries.

AMONG OTHER THINGS. . .

WITH this issue, we start the promised department for radio service men. The service man is a most important element in the present radio structure but for some reason or other he has been inarticulate. We know that a great many readers of RADIO BROADCAST are doing service work, either on whole- or part-time and we hope that those who are doing this work will write us, telling of their problems, how they are being solved, and of topics they would like to see discussed. Incidentally, the head of one of the largest New York organizations specializing in this work, Mr. John S. Dunham, writes: that although he believes service articles are of real value that "the average service man could derive far greater benefit by painstaking, thorough study of RADIO BROADCAST's Data Sheets from the beginning and the very excellent series of Home Study Sheets, recently inaugurated. From our own experience, we believe that service men generally need to increase their basic knowledge." With this, we agree, but we are certain that the experiences of service men are of deep interest to others working in the field. It certainly goes without saying that no service man can really do his work intelligently unless he has a thorough background in fundamentals.

THE application of power amplifiers, microphones, moving-coil loud speakers and similar apparatus for so-called public- or group-address work seems to be increasing rapidly. This development is a natural and fortunate one and in our opinion due largely to the increasing appreciation of what good radio apparatus can do. The question which most frequently comes up is not the simple one of how to connect or to operate the gear but what power output is essential for a given service. RADIO BROADCAST Laboratory Data Sheets Nos. 245 and 246 in this issue discuss this interesting question.

EARLY in 1926, Mr. Howard E. Rhodes joined the staff of RADIO BROADCAST and since that time, his excellent articles have added much to the interest and technical value of our pages. The popular Laboratory Data Sheets are Mr. Rhodes' work. We are pleased to announce that effective November 1st, Mr. Rhodes was appointed Technical Editor of this magazine.

THE current issue contains many articles on subjects of great interest to many radio folk. Notable among these are the following: the article on cutting and grinding quartz crystals, the data on underground antennas in "Strays from the Laboratory," the references to sources of information on sound movies, the article on experimental band-pass filters, the discussion of moving-coil and "magnetic" type loud speakers, Mr. Kruse's article on amateur experimenting and finally Boyd Phelps' description of his ingenious work in television synchronizing which is found on page 123.

THE January issue will contain the long-promised article on moving-coil speakers and is worth waiting for. Constructional stories on interesting receivers, and power amplifier units are promised as well as more useful data for the experimenter and service man.

—WILLIS KINGSLEY WING.

DOUBLEDAY, DORAN & COMPANY, INC., Garden City, New York

MAGAZINES

COUNTRY LIFE
WORLD'S WORK
THE AMERICAN HOME
RADIO BROADCAST
SHORT STORIES
LE PETIT JOURNAL
EL ECO
FRONTIER STORIES
WEST
THE AMERICAN SKETCH

BOOK SHOPS (Books of all Publishers)

NEW YORK: LORD & TAYLOR; JAMES MCCREERY & COMPANY
PENNSYLVANIA TERMINAL AND 166 WEST 32ND ST.
848 MADISON AVE. AND 51 EAST 44TH STREET
420 AND 526 AND 819 LEXINGTON AVENUE
GRAND CENTRAL TERMINAL AND 38 WALL STREET
CHICAGO: 75 EAST ADAMS STREET
ST. LOUIS: 223 N. 8TH ST. AND 4014 MARYLAND AVE.
KANSAS CITY: 920 GRAND AVE. AND 206 WEST 47TH ST.
CLEVELAND: HIGBEE COMPANY
SPRINGFIELD, MASS: MEEKINS, PACKARD & WHEAT

OFFICES

GARDEN CITY, N. Y.
NEW YORK: 244 MADISON AVENUE
BOSTON: PARK SQUARE BUILDING
CHICAGO: PEOPLES GAS BUILDING
SANTA BARBARA, CAL.
LONDON: WM. HEINEMANN, LTD.
TORONTO: DOUBLEDAY, DORAN & GUNBY, LTD.

OFFICERS

F. N. DOUBLEDAY, Chairman of the Board
NELEON DOUBLEDAY, President
GEORGE H. DORAN, Vice-President
S. A. EVERITT, Vice-President
RUSSELL DOUBLEDAY, Secretary
JOHN J. HESSIAN, Treasurer
LILLIAN A. COMSTOCK, Asst's Secretary
L. J. McNAUGHTON, Asst's Treasurer

**164
PAGES**

This big catalog places before you one of the country's largest — and most complete stock of radio kits, parts, accessories and consoles as well as one the season's outstanding lines of both A-C and D-Creceivers. Every set builder — every dealer, in fact all those interested in radio should send for their copy of this immense catalog.

WHOLESALE PRICES

On Everything
in **RADIO**

RADIO
MODERN RADIO SETS
ACCESSORIES KITS AND PARTS
OF
1929

**ALLIED RADIO
CORPORATION**
711 W. LAKE ST. CHICAGO, ILL.

CONFIDENTIAL
WHOLESALE
PRICES

RADIO SERVICE

Allied Service will prove a revelation to you in what radio service can really be. Allied Executives backed by years of training in radio, are practical men. They know radio. Their vast experience has built up around them an organization trained to serve. Months of effort have built up a tremendous reserve of stock that makes for prompt shipments; and this stock is new stock comprising the season's pick of such prominent manufacturers as Silver-Marshall, Tyrman, Aero, Hammerlund-Roberts, etc.

SET BUILDERS!

Set Builders, Amateurs and so-called "Hams" will delight in the *unusual variety* and *remarkable values* that are offered in standard kits and parts. Tremendous stocks — *real organization* — prompt shipping service all combine to make Allied your ideal source of supply.

RADIO DEALERS!

The five radio dealer — the man who keeps pace with the rapid advance of radio — will find much of *real interest* in the Allied Catalog. New A-C Sets, D-C Sets, Dynamic and Magnetic Speakers, Television equipment, in fact everything an impatient radio public is demanding.

Write for Catalog Now!

Allied Radio CORPORATION

711 W. LAKE ST. Dept. A-3 CHICAGO

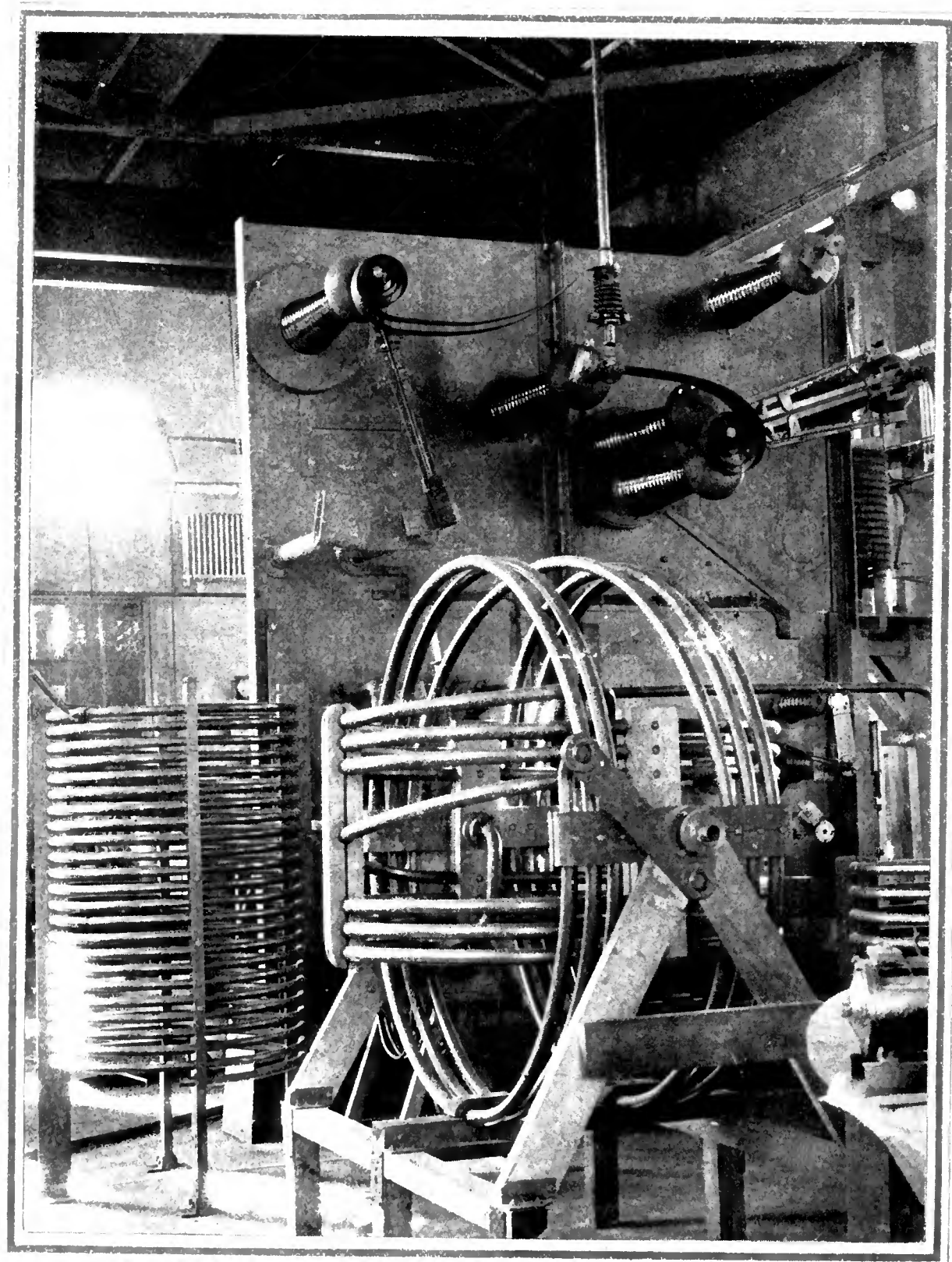

Old Sayville Station Returns to Limelight

Herman P. Miller, chief transmission engineer of the Federal Telegraph Company, is stationed at Sayville, Long Island, for the purpose of reconditioning the once-famous radio transmitter which was built there by the Germans in 1912. This station was taken over by the U. S. Navy during the World War and abandoned in 1925; however, it may soon be one of the most powerful marine stations in the world. This interior view shows a portion of the transmitting equipment. The remotely controlled switching apparatus is mounted on the large panel in the rear, on the left is the adjustable inductor for tuning the counterpoise, and the variometer in the foreground is connected in the antenna circuit.

QUARTZ CRYSTALS

How to Cut and Grind Them

By R. C. HITCHCOCK



FIG. 1. A NATURAL QUARTZ CRYSTAL CUT IN FOUR PARTS

MOST radio experimenters are now familiar with the advantages of using a quartz crystal to control a radio-frequency transmitter. Although many articles have been written on the use of a quartz-crystal oscillator, the actual procedure of cutting a proper plate from a crystal of quartz has received relatively little attention.

This article is concerned mainly with the actual operations and calculations used in cutting and grinding a quartz oscillator plate from a quartz crystal. It should be noted that a quartz-crystal oscillator does its most reliable work when certain factors are kept constant. These are plate and filament voltages, plate and "tank" circuit tuning, and most important of all, the temperature of the crystal.

Assuming the tuning to remain fixed, when a crystal temperature is maintained constant, the ordinary plate and filament voltage variations cause only small frequency changes in a crystal-controlled circuit. The frequency of such a crystal-controlled circuit varies about one five-hundredth as much as that of a similar tuned grid-oscillator circuit with the same plate and filament voltage variations.

SELECTING THE RAW MATERIAL

A PERFECT quartz crystal is rare, but fortunately a perfect crystal is not required for an oscillator. There are a few simple tests for determining the suitability of a quartz crystal, which require only the unaided human eye. A good quartz crystal may be rough and dirty on the outside, but generally is clear inside when viewed by the naked eye, showing no colors or dark regions. It also must be free from bubbles and cracks. Quartz is often cracked mechanically during mining. This of course would make it unsuitable for oscillator use, as a crack would lengthen into a complete break.

The optic axis of the quartz crystal, so called because of the unique optical effects obtained in this direction, is located parallel to the edges

formed by adjacent hexagonal crystal faces. It is in the direction of the dimension W in Fig. 3.

For reference in cutting as well as convenience in clamping, a crystal should have at least one of its natural hexagonal faces present. An ordinary crystal has all six hexagonal faces, and a pyramidal point on one end. The end opposite the point is generally full of flaws and is broken off in mining. Fig. 1 on this page shows a natural quartz crystal, with the first three cuts made for crystal oscillators. The left section contains the point, and is of a quality suitable for oscillator use. The right-hand section is full of



CRYSTAL-CONTROLLED transmitting stations are rapidly becoming the rule rather than the exception. The new amateur bands which become effective in 1929, and the insistent demand for greater frequency stabilization among broadcasting stations, make it imperative that transmitters use quartz plates which will hold the frequency of the station within very close limits. These plates must be sawed from quartz crystals, and then ground to the desired thickness. This article, by R. C. Hitchcock, of the Westinghouse Electric & Mfg. Co., gives the details of the modern technique of crystal grinding, and should appeal to amateurs and broadcast station engineers alike.

—THE EDITOR.



bubbles and other flaws which make it unsuitable for an oscillator.

Although the pyramid at the point of a quartz crystal is bounded by true planes, the hexagonal sides are seldom planes, their faces more often showing striations. These striations resemble steps, the crystal cross-section being gradually made smaller by these definite steps in the direc-

tion of the point. Striations are sometimes closer than $\frac{1}{16}$ inch and quite deep, and others may be over an inch apart and so shallow that the crystal must be examined closely to distinguish them.

The striations, if they are present, are useful as reference marks, as the first cuts are to be made in exactly the direction of the striations, that is, perpendicular to the hexagonal faces of the crystal.

The usual specifications for a good quartz crystal, or rock crystal, for oscillator cutting are that it should be free from twinning, have no flaws, and be of optical quality. It is true that sometimes a crystal plate is a satisfactory oscillator while all the other properties mentioned above are lacking. But in general, until one has had experience and is willing to risk cutting plates with the certainty that some will not oscillate, the best recommendation is that the proper quartz crystal be secured from a reputable dealer in minerals.

The cost of a quartz crystal depends on its size and quality. For the quality specified above the usual price is about five dollars a pound. A crystal $2\frac{1}{2}$ " across the hexagonal flats, and 3" over all in length, weighs about a pound. For larger crystals the price per pound increases. Clear quartz crystals having dimensions all less than one inch are quite cheap, but are not large enough for quartz oscillators. These tiny crystals can be used in fused quartz work and for ceramic glazes, and are sold for a few cents a pound.

CUTTING QUARTZ

QUARTZ is very hard and some form of machine for cutting is advised, although for grinding quite satisfactory work may be done by hand. Fig. 2 shows how an inexpensive polishing head may be arranged for cutting a quartz crystal. A lathe could also be used for this work, but special precautions would have to be taken to prevent the grinding compound from ruining the bearings and the ways.

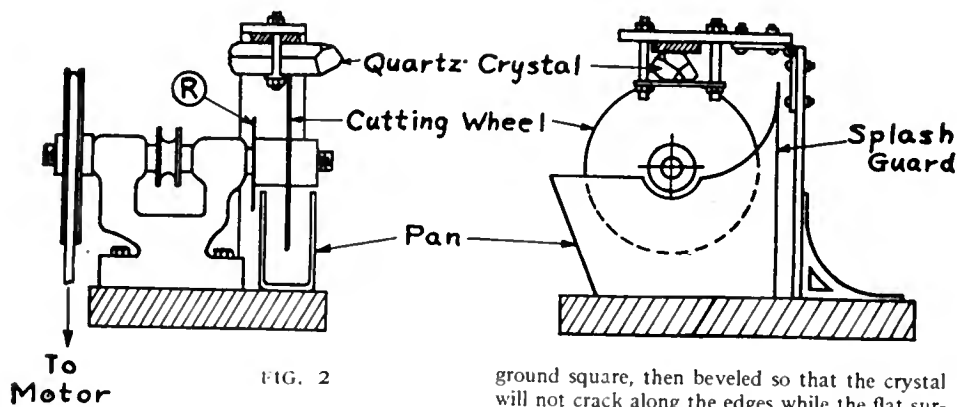

FIG. 2

A copper or brass disc $\frac{1}{16}$ " thick and 6" to 8" in diameter revolves in a pan nearly filled with No. 150 carborundum and water. More of this cutting compound has to be added as the cutting progresses, as a good deal of the material splashes out. Shields should be placed to prevent the spattering of walls and floors if the cutting apparatus is set up at home. A splash guard should also be provided as shown in Fig. 2, and a ring, R, put on the shaft to prevent the compound from working into the bearings. During cutting, the compound in the pan should be stirred so that the carborundum is kept in suspension.

The crystal is bolted to a hinged piece as shown in the figure. A thin wooden block is placed on top of the crystal so that the crystal will be cut clear through before the cutting wheel reaches the hinged piece. The cutting speed should be 250 r. p. m. or slower. If an 1800 r. p. m. motor is used, the pulley on the polishing head should be $1800/250 = 7.2$ times as large as that on the motor. A motor of $\frac{1}{4}$ h. p. is about the right size when the crystal rests on the pan on the cutting wheel, as shown in Fig. 2. About twenty minutes will be taken to cut through a two-inch crystal. If a weight is added to the crystal to make it feed faster, a more powerful motor will be required.

As shown in the picture in Fig. 1, the first cuts are to be made perpendicular to the crystal's hexagonal faces, and the section cut will be a right prism. These cuts should be 1.25" apart so that the finished size can be made 1.10" or 28 mm. This width dimension is called W in Fig. 3.

METHODS OF SLICING QUARTZ CRYSTALS

TWO methods of slicing an oscillator crystal from the right prism are shown in Fig. 3. The original method, given in 1880 by the Curies, is still used for all low-frequency crystals, and sometimes for high radio-frequency crystals. This is shown as Method 2. For frequencies higher than 600 kc. (less than 500 meters wavelength) a Method 1 crystal controls more power, is easier to make oscillate, and uses less quartz. For a given frequency a Method 1 crystal is about two-thirds as thick as a Method 2 crystal.

Fig. 3 shows clearly how the slices are made; a Method 1 plate has its faces parallel with the crystal hexagonal faces; a Method 2 plate has its faces at right angles to these faces. The dimensions L and W are not critical but good results will be obtained if L is about 1" or 25 mm, W being about 1.10 inch, or 28 mm.

The quartz prism is bolted to the hinged piece and slices made according to Method 1 or 2 are cut. The cutting disc wastes material and does not cut squarely, so a larger slab should be cut than is needed for the actual crystal size. For frequencies above 600 kc. a slice $\frac{3}{8}$ " to $\frac{1}{2}$ " thick should be made.

The edges of the L and W dimension are

ground square, then beveled so that the crystal will not crack along the edges while the flat surfaces are being ground.

The distance T is the oscillating dimension and Fig. 5 gives the value of T for frequencies between 600 and 4000 kc. The frequency and wavelength are given in the left column, and the oscillating dimension in both millimeters and inches is given in the right column. The short center column is a constant K, called the "meters per millimeter," meaning that for each millimeter of a quartz oscillator there is a definite electromagnetic wavelength. The larger T is, the longer is the wavelength, λ , the relation being

$$\lambda = K T \quad (1)$$

The "meters per millimeter," or K, is found by

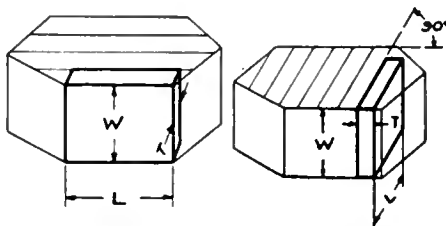

METHOD 1

METHOD 2

FIG. 3

dividing both sides of equation (1) by T, so that

$$\frac{\lambda}{T} = \frac{\text{meters}}{\text{millimeter}} = K \quad (2)$$

For Method 1, K varies from 140 to 150 meters per millimeter, while for Method 2, K is 100 to 110 meters per millimeter.

To use Fig. 4, line up the frequency at the left column, with K in the center column, finding T in the right hand column.

To be on the safe side, it is best to use the smaller value of K for preliminary work so that the crystal will be thick enough to allow for a final adjustment. For precision better than 10 per cent. a wavemeter or some source of standard frequency should be used. Fig. 5 gives only approximate values of T. A more exact method of figuring T and how to find the proper K for a given piece of quartz will now be given.

CALCULATING K FOR A CRYSTAL

QUARTZ crystals have different values of K, as noted above, and the only sure way to know the frequency is to measure it. However, a fair determination of K can be made for a given crystal, if the frequency is measured. Suppose a Method 1 crystal for 1800 kc. is wanted, and the value of 140 meters per millimeter for K is used. This shows T to be 1.19 mm. When T is ground to 1.19 mm. the frequency is measured to be 1760 kc. sec. Using equation (4), to be derived later, it will be found that the correct K for this piece of quartz is.

$$K = \frac{300,000}{T F} = \frac{300,000}{1.19 \times 1760} = \frac{143 \text{ meters}}{\text{millimeters}}$$

Putting this value of K in equation (4), the correct T is

$$T = \frac{300,000}{K F} = \frac{300,000}{143 \times 1800} = 1.166 \text{ millimeters}$$

The thickness measurement is used for convenience in grinding, and is not as reliable as a measurement of the frequency. The final adjustment of a crystal for frequency should be made with a wavemeter or some known standard of frequency.

For testing, the oscillator circuit of Fig. 4 is suggested. A 10,000-ohm wire-wound resistor and C battery provide grid bias. The use of a grid choke coil should be discouraged; a good crystal does not need it, and a crystal which will not oscillate without a choke should not be depended on for control. At 1000 kc. over 50 watts can be obtained from a single crystal-controlled tube using only a grid resistor, and no grid choke. For power work, from 20 to 50 watts, the crystal must be kept at a fairly low working temperature to prevent overheating.

For frequencies below the broadcast band, and as low as 25 kc. / sec., crystals are cut by Method 2, oscillating along the L dimension, T being from 2 to 4 mm. K has the same meaning for these low frequencies as for the regular Method 2 crystals oscillating in the T dimension.

NECESSARY PLANENESS OF CRYSTAL PLATES

THE faces of an oscillator plate should be as nearly flat and parallel as possible. That is, T should be the same throughout the crystal in order to have the whole crystal oscillating usefully as a unit. Tests have shown that the best crystals have variations in T such that the corresponding natural frequencies are not more than .5 kc. different. For instance, a 1000-kc. crystal may have thicknesses corresponding to frequencies ranging from 999.75 to 1000.25 kc. This makes it necessary to grind a high-frequency crystal very accurately plane and faces parallel, the accuracy required increasing as the square of the frequency.

If λ is the wavelength in meters, and F the frequency in kc. sec., the well-known relation is

$$\lambda = \frac{300,000}{F} \quad (3)$$

Eliminating λ between equations (1) and (3),

$$K T = \frac{300,000}{F} \text{ or } T = \frac{300,000}{K F} \quad (4)$$

To find the relation between small changes in T and F, equation (4) is differentiated, giving

$$dT = \frac{-300,000}{K F^2} dF$$

For frequencies from 600 to 4000 kc. the curves of Fig. 6 give the thickness variation, dT, for a frequency variation dF = .5 kc. To take a particular case, a Method 1 crystal of 3000 kc. should have a thickness variation of only 8.5 ten thousandths of a millimeter, or 3.3 hundred thousandths of an inch, if the .5-kc. variation is allowed. From Fig. 6 it will be seen that Method 1 crystals must have only two thirds as much thickness variation as Method 2 crystals of the same frequency. This offsets to some extent the

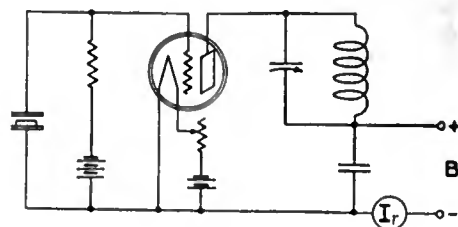

FIG. 4

advantage of using less quartz for the Method 1 crystal. However, the advantage of greater power still favors the Method 1 plate.

Accuracy as great as given above is impossible by ordinary grinding but indicates the desired goal. Crystals with thickness variations twenty times as great as given by Fig. 6 are often good enough, even though their frequencies are 10 kc. different at various points. If a crystal is ground with two frequencies nearly the same—for instance, one half the crystal at 1000.0 kc. and the other half at 1000.5 kc.—an audible beat note of .5 kc. will probably be produced and the crystal will not be satisfactory for control. This will not occur if the two thicknesses are irregularly spaced over the whole crystal.

For very high frequencies, due to the difficulty in making crystals plane enough, it is recommended that a low-frequency crystal be used in a circuit whose harmonics are amplified to obtain the desired high frequency.

GRINDING QUARTZ

THE thickness grinding may be done by hand, using a micrometer to measure the thickness. Crystal plates should be ground with their faces oriented as nearly as possible like the plate shown in Fig. 3. However, if a crystal has its faces quite accurately parallel, a change of a few degrees in having the crystal plate line up with the one shown in Fig. 3 is not serious except as it changes the value of K. As this factor varies for

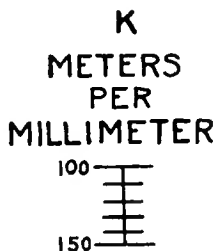
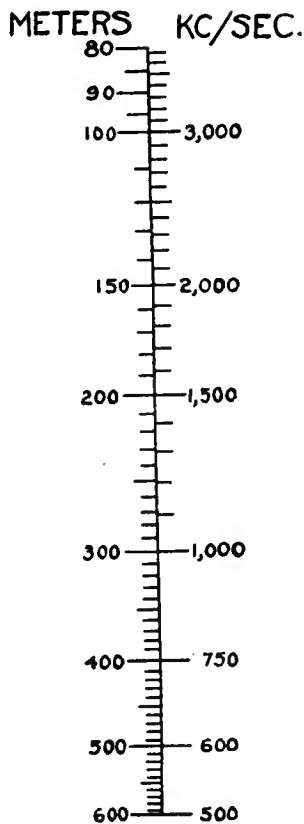
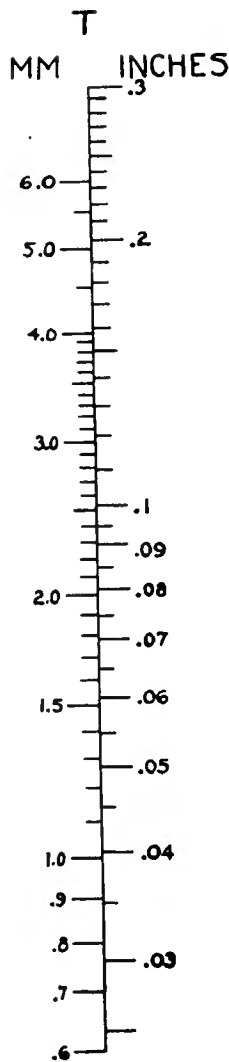

FIG. 5

different crystals, and has to be determined for each one by a frequency measurement, the important thing is to have the faces parallel.

Gasoline or benzol should be kept handy to clean the grinding compound from the crystal before measuring or testing in a circuit. After cleaning, a crystal should be handled as little as



possible to prevent getting grease on it from the fingers.

For the first stages of grinding an ordinary piece of glass is flat enough. First use No. 150 carborundum, then 302½ and 303½ emery. Pour the powder upon the glass, adding a few drops of water, and mix it with the powder to make a grinding paste. Move the crystal plate around in circles, holding it with the finger tips. If desired, the crystal may be fastened to a block of metal with low melting wax, and the metal block held by hand.

During grinding the thickness should be measured from time to time; be careful not to grind down the edges too far. If a certain spot is too high, a small brass piece charged with the grinding compound should be rubbed over it.

When approximately the right thickness by micrometer, a crystal should be tried in its circuit and the frequency measured. If the frequency is much too low, a new calculation of T should be made, as already mentioned.

Sometimes a crystal jumps abruptly to a higher frequency during grinding, just before the calculated thickness is reached. This does not necessarily mean that this crystal is useless, as often the frequency will jump lower by grinding either L or W a little, of the order of 0.020 inch. If a crystal refuses to oscillate when thin, although it oscillated well when thicker, this is due to irregularities in the T dimension, and a grinding off of the high spots will cause the crystal to oscillate.

When using a micrometer as the sole means of testing a crystal plate thickness the plate often deviates from a plane, the reason being that a hollow on one side and a high spot on the side corresponding can not be detected by an ordinary micrometer. When grinding very thin crystals this is especially likely to happen, and often prevents the oscillation of an otherwise satisfactory crystal plate. One remedy is to use a metal straight edge as a reference in keeping the crystal plate flat and free from high or low spots. The crystal is held up to the light, and the straight edge moved slowly over the surface. The high spots will be seen to touch the straight edge, and cracks of light will indicate low portions.

Polishing with rouge may be done with a leather surface, but if the thickness is nearly as good as the 0.5 kc. variation of Fig. 6 gives, no great increase in power or other advantage will be gained by polishing the faces of the quartz crystal.

It has been shown that high-frequency crystals must be very accurately flat and parallel. The grinding of the thickness is by far the most important item of the whole operation of grinding a crystal. A few hours spent in careful and painstaking work in grinding the thickness will be repaid by the successful operation of the quartz oscillator crystal plate.

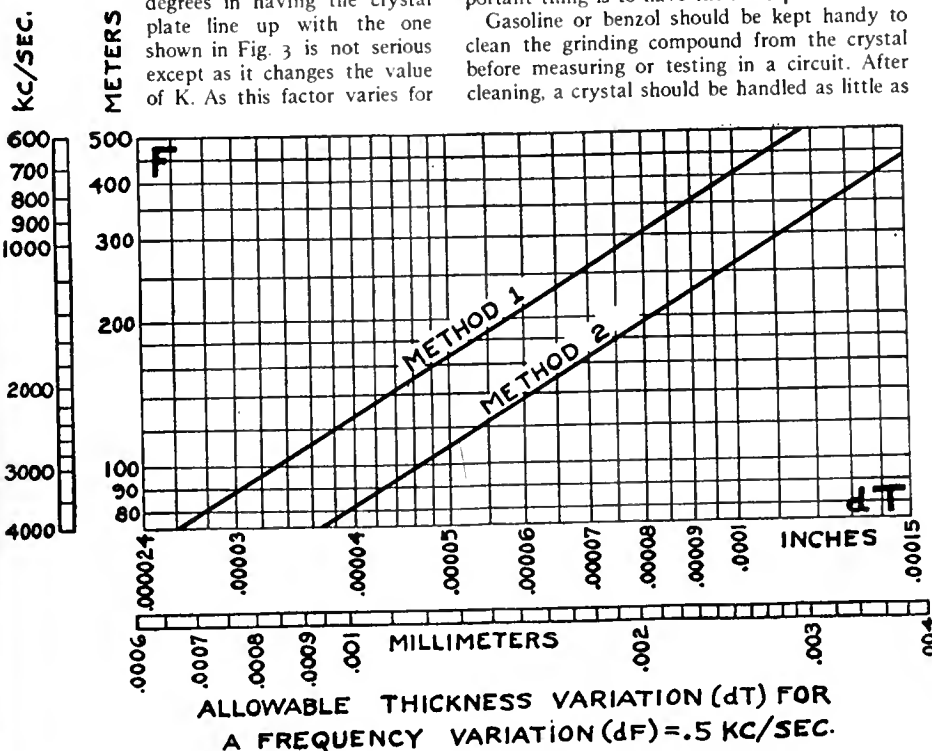

FIG. 6

Phonograph-Radio Amplifiers

HOWARD E. RHODES

Technical Editor

THERE is a natural link between the phonograph and the radio, for they both constitute means of bringing entertainment into the home. In a sense neither is quite complete without the other and both may be combined advantageously into a single instrument. There are many commercial examples of this—Victor, Columbia, etc.—with which the reader is probably familiar. From a small but carefully selected group of records one can obtain a great deal of pleasure, and, when the radio program becomes tiresome (as it frequently does), it is convenient to be able to turn on the phonograph and listen to one's favorite selection. The pictures in this article illustrate some apparatus, both home-constructed and manufactured, that can be utilized readily in assembling a phonograph-radio combination.

What apparatus do we need? For the radio set we require a tuner with which we may select and detect the radio signal, an audio amplifier, and finally a loud speaker. For the phonograph we require an electrical pick-up unit, an audio amplifier and a loud speaker. The audio amplifier and loud speaker may be arranged so that they may be used interchangeably with either the radio or the phonograph; these two sections will differ, therefore, only in the first part, a tuner being used for radio and an electrical pick-up for the phonograph. This article is devoted to a description of an amplifier and loud speaker combination designed to fit into the lower compartment of a cabinet which also contains space for a radio receiver; located in the top of the cabinet is a phonograph turntable. All of the apparatus may, of course, be light-socket operated. The choice of apparatus should be limited only to the extent that good parts must be used. The apparatus can be arranged in any fashion suiting the desires of the individual constructing the set.

The picture, Fig. 1, is typical and shows the

installation of an audio amplifier in the bottom compartment of a cabinet designed to house a phonograph and radio. The loud speaker is placed on the baseboard on which the audio amplifier was constructed. The inside of the cabinet has been lined with a layer of porous material so as to prevent to some extent cabinet resonance which tends to make some loud speakers boom at the low frequencies. The blank space at the upper part of the cabinet is for the radio tuner; we have not shown a receiver in this position because we wish to make it quite evident that any good tuner may be used, be it tuned r.f., superheterodyne or any other type. The lid on the cabinet, shown in a slightly opened position, closes down on the compartment holding the phonograph turntable. There is ample room in this compartment to permit placing the electrical pick-up in the correct position relative to the turntable.

In front of the loud speaker is placed a baffle-board shown in the picture lying against the left door. This baffle should preferably be constructed of a piece of board about 1 or 1½ inches thick of such dimensions as to fit into the opening in the cabinet. To hold the baffleboard in place it may be screwed to the front of the baseboard on which the amplifier is constructed. There is supplied with this cabinet a decorative screen which fits in front of the baffle and helps

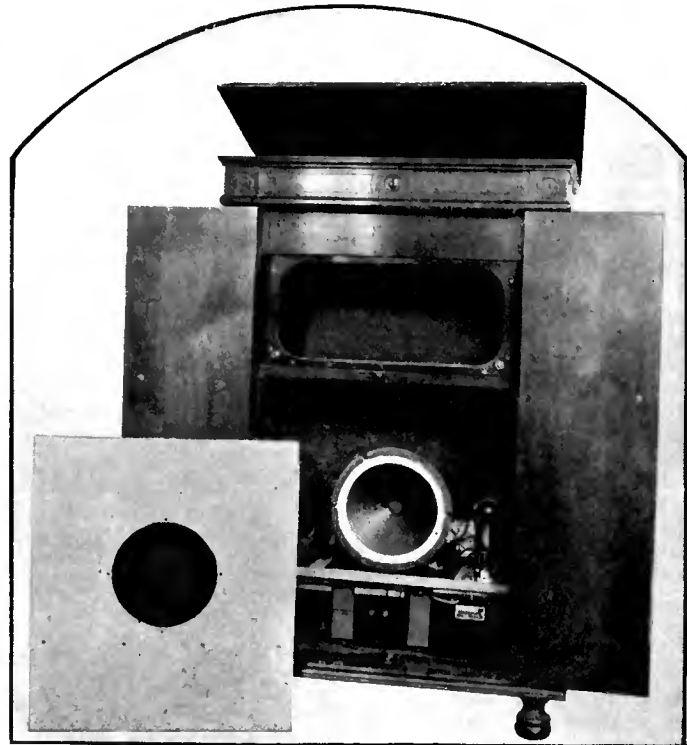

FIG. 1. THE PLATTER PHONOGRAPH-RADIO CABINET WITH AN AMPLIFIER AND REPRODUCER IN THE LOWER COMPARTMENT

to improve the final appearance of the instrument.

The amplifier, shown in Fig. 2, constructed in the laboratory to give the reader an idea of the kind of apparatus which may be utilized (any good amplifier may, of course, be used), employs an a.c.-operated two-stage transformer-coupled circuit. A 227-type tube is used in the first stage and a 250-type power tube in the output stage. The output of this tube—about 4.5 watts—is more than enough for all purposes.

LIST OF PARTS

THE circuit diagram of this amplifier is given in Fig. 3, and those who have had experience in the home construction of such units will obtain the information they require from the circuit diagram and the pictures. Those who haven't had such experience will do better, we feel, to buy a complete amplifier or a complete kit of parts, which can be assembled very easily. The parts used in the amplifier are listed below. Other makes of parts electrically equivalent may, of course, be used.

The following is a list of the apparatus used in the power amplifier constructed in RADIO BROADCAST'S Laboratory:

- C₁, C₂, C₃, C₄ Four Acme Parvult by-pass condensers, 1-mfd., 400-volts;
- C₅, C₆ Two Acme Parvult filter condensers, 2-mfd., 1000-volt;
- C₇ One Acme Parvult filter condenser, 4-mfd., 600-volts;
- C₈, C₉, C₁₀, C₁₁ Four Acme Parvult by-pass condensers, 1-mfd. 400-volt;
- L One dial light, 5-volt;
- L₁, L₂ Two Samson filter choke coils, type-312, 30-henry;
- R₁, One Ward Leonard fixed resistors, 5000-ohm;
- R₂ One Ward Leonard fixed resistor, 2000-ohm;
- R₃ One Polymet metallized grid leak, 25,000-ohm, type G-1303;
- R₄ One Ward Leonard resistor, 5000-ohm;
- R₅ One Polymet metallized grid leak, 25,000-ohm, type G-1303;
- R₆ One Polymet wire-wound resistor, 1500-ohm, type, W-1702;

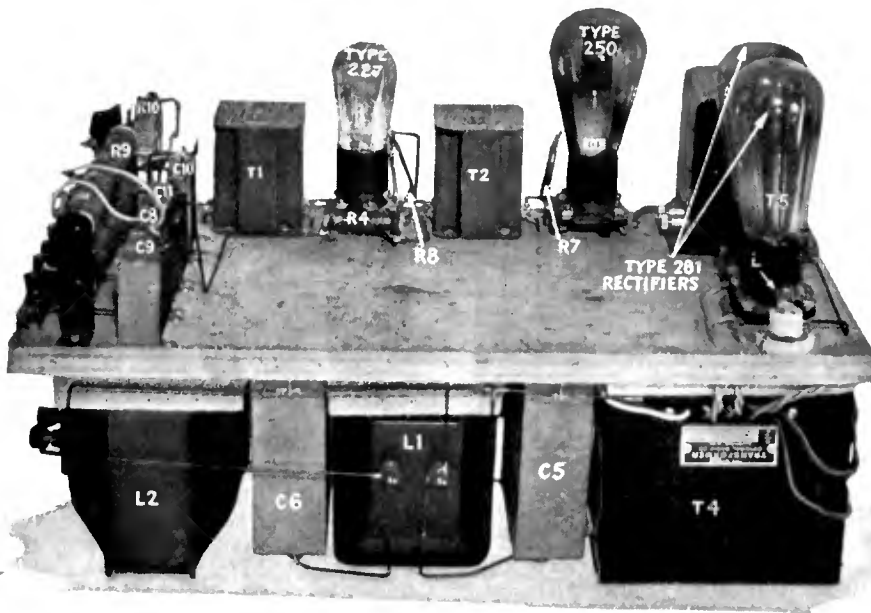

FIG. 2. THE PHONOGRAPH-RADIO AMPLIFIER CONSTRUCTED BY THE WRITER

- R₁ One Electrad Truvolt resistor, 50-ohm, type V-50;
 - R₂ One Electrad Truvolt resistor, 10-ohm, type V-10;
 - R₃ One Ward Leonard resistance bank, type 507-6;
 - R₁₀ One Centralab power potentiometer, 175-ohm, type PF-175;
 - T₁, T₂, Two Sangamo audio transformers, type A;
 - T₃ One National filament-lighting transformer;
 - T₄ One General Radio power transformer, type 565-B;
 - T₅ One General Radio loud-speaker filter, type 587-B;
 - Three Benjamin sockets, ux-type;
 - One Benjamin socket, uy-type;
 - Belden Hook-up wire;
 - Eight Eby binding posts;
 - One Platter orthophonic cabinet, type PR-918.
- The following tubes are required:
- One power tube, 250-type;
 - Two rectifier tubes, 281-type;
 - One tube, 227-type.

The input to the amplifier is through leads Nos. 1 and 2 which form a complete circuit

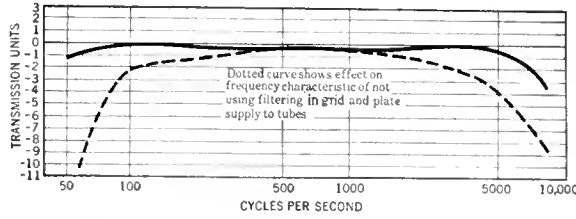

FIG. 4. RESPONSE CURVE OF THE AMPLIFIER DESCRIBED IN THIS ARTICLE

for the audio-frequency currents, these currents being kept out of the B-supply unit by the resistor R₁. Filter systems, consisting of resistors and by-pass condensers, are used in the grid and plate circuits of the 227-type tube, and also in the grid circuit of the 250-type tube, for the purpose of keeping all of the audio-frequency currents out of the B supply. The filter in the grid circuit of the 227-type tube consists of R₂, C₂, the plate-circuit filter is R₄, C₃ and the grid-circuit filter of the 250-type tube is R₅, C₄. The output of the amplifier feeds into the choke-condenser unit T₅.

The B-supply unit for the amplifier is conventional, consisting of two 281-type tubes in a full-wave rectifier system. In series with the output of the rectifier is placed a small 5-volt flashlight bulb, L. If a short circuit occurs in the filter system, or at any other point in the circuit, the current through this lamp will increase sufficiently to burn it out, thereby protecting all the apparatus from damage.

The excellent frequency characteristics of this amplifier are indicated by the solid curve in Fig. 4. To give an idea of the importance of the various filter circuits, mentioned in a previous paragraph, we have also shown in dotted lines the frequency-characteristic curve of this amplifier without the filters. The importance of such filtering is obvious.

The home experimenter who likes to construct his own gear may desire to build such an amplifier as we have described, but the professional set builder who has or hopes to get some orders for the construction of a phonograph-radio combination can do the job more quickly by buying a kit of parts or a completely wired amplifier.

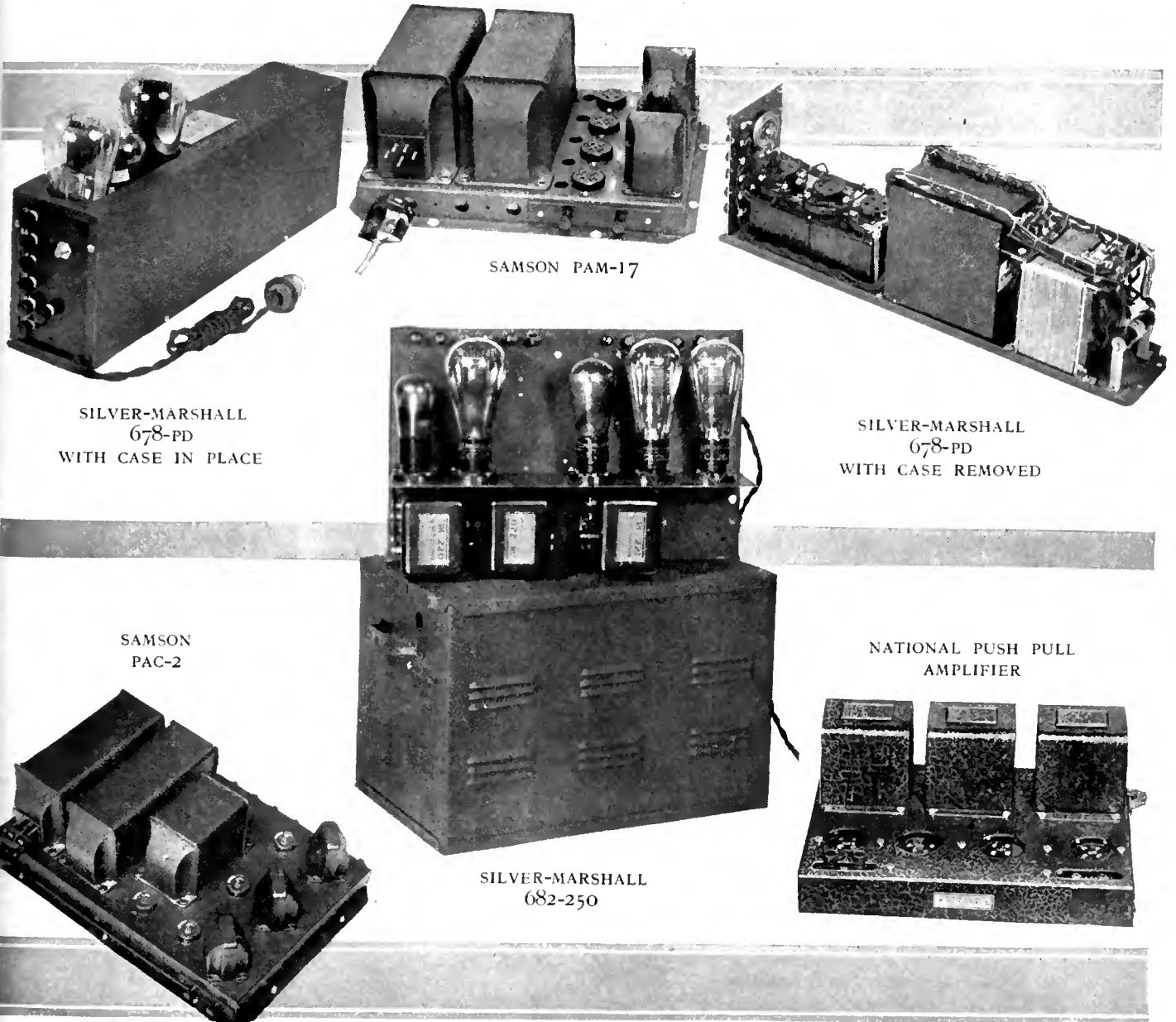

FIG. 5. A GROUP OF AMPLIFIERS SUITABLE FOR USE IN PHONOGRAPH RADIO COMBINATIONS

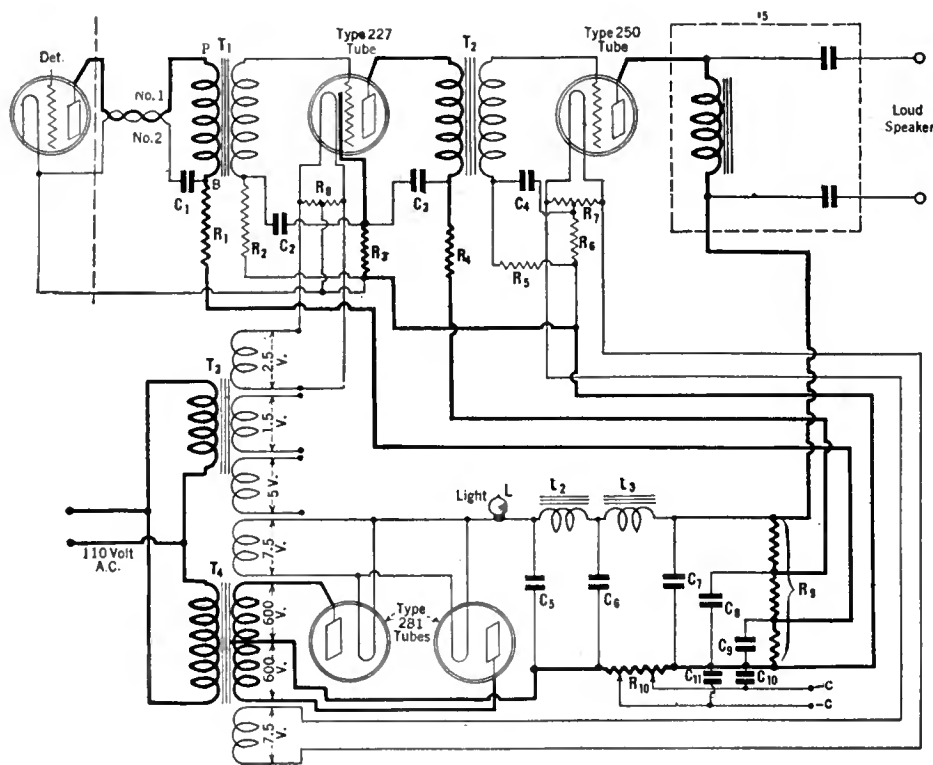

FIG. 3. SCHEMATIC DIAGRAM OF THE WRITER'S AMPLIFIER

Many such amplifiers are made—several are illustrated here—and a list of a few of the best units, with their characteristics, is given in Table 1.

COMMERCIAL POWER AMPLIFIERS

IN FIG. 5 are illustrated two Silver-Marshall "Unipacs;" both of them satisfactory for use in a phonograph-radio combination. Data on these and other S-M. amplifiers is given in Table 1. As indicated, these amplifiers may be obtained either completely wired or in kit form. The 678-PD amplifier is especially interesting in connection with this article since the circuit is arranged so that the field of the dynamic loud speaker acts as the filter choke and is energized by the d.c. current flowing through the filter circuit. This amplifier, with its 250-type output tube is capable of supplying up to 4.5 watts of undistorted audio-frequency power, to the loud speaker.

In Fig. 5 are illustrated also some of the power amplifiers made by the Samson Electric Company, which may be used in constructing a phonograph-radio combination, or any other unit from which high-quality reproduction may be desired. Data on the various models are given in Table 1. It will be noted that the amplifier PAM-17 is similar to the PAM-16 except that it supplies field current for a dynamic loud speaker. The type PAC-2 amplifier should be used where the unit is also to supply B voltages for the radio tuner. This amplifier, it will be noted, also supplies a C voltage of minus 4½ volts which may be used to bias the grids of the r.f. tubes in the receiving set.

The National Company also makes a power amplifier that may be used. This amplifier is also illustrated in Fig. 5, and Table 1 gives complete data on the various models. Model 8110 is a complete power amplifier and B-supply unit, but the Push-Pull amplifier does not contain any power supply and, therefore, must be used with a separate power unit designed to supply the

necessary A, and B voltages to both the amplifier and the radio-tuner unit.

A large number of special amplifiers which, in some cases, may be adapted to phonograph-radio combinations, are also made by many manufacturers, including those mentioned in Table 1. As an example we might consider the installation of power-amplifier equipment in a hotel. In such a case one would require one or more amplifiers arranged in the form of a group, each amplifier supplying a certain portion of the power for the loud speakers. The utility of such an installation is, of course, increased if it is arranged so that music from either radio stations or phonograph records can be transmitted throughout the system. When this arrangement is employed it is necessary to connect the input posts of all the amplifiers to the same set of terminals, and a switching system is needed to connect either the output of a radio receiver or the output of a phonograph pick-up to these terminals. Any readers interested in the details of such amplifiers will do well to write the manufacturers mentioned in this article for complete descriptions of this equipment.

An excellent power amplifier which, unfortunately, is not illustrated in this article, is the Amertran type 2-AP. This is a complete two-stage transformer-coupled amplifier, the output stage being push-pull. Either 171- or 210-type tubes may be used in the push-pull stage and the first audio amplifier tube may be either a 227- or a standard 201A-type tube.

Table 1—Data on Power Amplifier Units and Kits

Manufacturer	Type No.	Prices		Voltages Available for Receiver		Description of Amplifier
		Kit	Wired	B Voltages	A. C. Voltages	
Silver-Marshall	682-250	\$96.50	\$111.50	45, 90, 135	1.5, 2.25	Two-stage transformer-coupled. 226 in first stage and one 210 or 250 in output stage. Rectifiers are two 281 tubes. An 874 glow tube is used.
Silver-Marshall	682-210	\$102	\$117	45, 90, 135	1.5, 2.25	Same as 682-250 except that output stage is push-pull. Either 210 or 250 tubes may be used.
Silver-Marshall	678-PD	\$66	\$73	None	None	Two-stage transformer-coupled. 226 in first stage and one 250 tube in output stage. Rectifier is one 281 tube. This model supplies current for field excitation of a dynamic loud speaker.
Samson	PAM-17		\$125	None	None	Two-stage transformer-coupled. 227 in first stage and 210's in push pull in output stage. Rectifier is one 281 tube. This model supplies current to the field winding of a dynamic loud speaker.
Samson	PAM-16		\$125	None	None	Same as PAM-17 except that no provision is made for supplying the field of a dynamic loud speaker.
Samson	PAC-2		\$175	45, 90, 135	1.5, 2.5	Two-stage transformer-coupled. 227 in first stage and 210's in push pull in output stage. Rectifier is one 281 tube. An 874 glow tube is used. This model also supplies a —4.5 volt C bias.
National	8110		\$85	45, 67 (adjustable)	None	Three-stage resistance-coupled. Uses one 210 power tube in output stage. Rectifier is one 281 tube. One 201A and one 240 are used in the first two stages.
National	8050		\$75	45, 67 (adjustable)	None	Same as type 8110 except that the output tube is a 250 and the rectifier is a type 280 tube.
National	Push-Pull Amplifier		\$40	None	None	This unit is a two-stage transformer-coupled push-pull amplifier using type 210 or 250 tubes in the output. It does not contain a power supply and must therefore be used with a separate unit such as the National Type 250.
American Transformer Co.	2-AP		\$60	None	None	Two-stage transformer-coupled. Either a 227- or 201A-type tube in the first stage and 171A- or 210-type tubes in the output stage which is push-pull. It does not contain a power supply.

THE MARCH OF RADIO

NEWS AND INTERPRETATION OF CURRENT RADIO EVENTS

Radio May Become the Cornerstone of the Amusement Industries

IT IS the privilege of all men to consider the age in which they live as the zenith of human progress. In our little world of radio, the last decade has been a kaleidoscope of evolution and to-day we stand at the brink of a titanic realignment of the communication and entertainment worlds, with the versatile vacuum tube as its cornerstone. We cannot escape the conclusion that this decade will prove the most significant in the history of the stage, the screen, the phonograph, and the broadcasting industry.

Radio has grown from a humble sideline of the electrical industry and a pursuit of the former amateur experimenter, who refused to abandon his hobby, to the position of key industry of the entertainment world. The application of vacuum tube amplification to practically every phase of aural and visual entertainment promises to make broadcast reception only one phase of the many-sided business which will constitute the radio industry of the future.

Five years ago, the prostrate phonograph industry was revitalized by adopting the methods of the broadcast studio in recording and the audio system of the radio receiver for reproduction. More recently, the motion-picture industry, by an almost identical process, has incorporated sound entertainment as an integral part of screen reproduction and is, in consequence, enjoying an amazing revival.

Slowly but surely, drama, concert, vaudeville, motion pictures, phonograph, and broadcasting are being drawn into the vortex to form a huge, unified entertainment business, destined to reach staggering proportions in volume of business and to achieve undreamed of heights in the character of entertainment and education which it brings to the home. By this process, also, the economic problems of broadcasting will be solved definitely and the spasmodic character of production in the industry significantly readjusted.

SOME PREVIOUS PREDICTIONS

IN THE January "March of Radio," we ventured some predictions as to an ultimate home-entertainment machine, comprising broadcast receiver, phonograph reproducer, radio picture recorder, film projector and, some day, television reproducer. Nebulous as this conception then appeared, it seemed to us inevitable because of the natural technical and artistic alliance of these once separated fields. In June, we were able to chronicle the first practical step in this direction, the rumored merger of the Radio Corporation of America and the Victor Talking Machine Company. To-day, all the important phonograph companies are in the radio business. Concurrently, came the talk-

ing-movie boom, utilizing many of the inventions developed for radio. More recent developments are providing the structure for the actual manufacture of such a device.

The principal motion-picture producers are licensed already by the Bell System to use one or both of their two methods of sound synchronized film systems. Vitaphone uses phonograph records mechanically synchronized with the film; Movietone records sound impressions directly on the edge of the film by means of a light shutter system. These light impressions are converted into sound at the motion-picture theatre by passing light through the sound track, upon a photo-electric cell.

The R. C. A. more recently entered the field by exploiting a system developed by the General Electric Company, using the oscillograph principle to make the sound record on the film. Having entered the field later, there are, as yet, only a few Photophone licensees, as the R. C. A. system is termed, but with the prospective alliance with the Keith-Albee-Orpheum circuits and the Film Booking Offices of America, a huge number of theatre installations by Photophone are in prospect. Several other systems are soon to appear. Acute shortage of equipment exists and there is a feverish rush to speed theatre installations for the reproduction of sound pictures.

At the present time, the R. C. A. and the Bell System are in competition in the sound-picture field. If the precedent of broadcasting is followed, a combination of these rival interests will be effected ultimately. Five years ago, the Bell System laid the foundations for the National Broadcasting Company by operating the first chain of stations with WEAJ as the key, while the

Radio Corporation and its associates maintained WJZ as the competing key station to a chain connected through telegraph lines. Intense competition proved uneconomic, with the result that the National Broadcasting Company was formed as a merger of the two systems.

UNIFICATION INCREASES EFFICIENCY

FROM the standpoint of efficient and economic operation, unification of broadcast studio management, concert bureau direction, recording of musical accompaniment for sound pictures, phonograph recording and vaudeville management is a natural alliance. The operation of broadcast input amplifiers, of electrically operated devices for phonograph recording and of sound-film recording devices, as well as of reproducing equipment in theatres and public address systems, is technically similar. Nothing could be more natural and logical than the merger of these activities.

There are, however, some practical obstacles to the joining of so many forces. Political sentiment is against the concentration in a single hand of so many potent means of influencing public opinion as are presented by broadcasting and motion pictures. The leaders in the radio field have, at no time, been in greater need of unified public support and of intelligent management of their public relations. The very fact that all the prospective mergers are announced as being only in the negotiation stage is recognition of the need for public approval in advance of actual consummation.

The principle of unification and concentration in industry is founded upon efficiency in public service. So long as the policies of huge corporations are directed with impartiality, we not only tolerate, but encourage the unification of such important agencies of general welfare as the telephone service. Likewise, we may look forward to centralization of broadcasting, motion pictures, phonograph recording and ultimately television, provided that service to every element of the public, every taste, every strata of society, and every shade of religious and political belief is considered in proportion to their needs. The actual completion of such mergings may have to await additional legal safeguards but, more likely than not, the immense detail of negotiation is the only immediate problem to be met.

The merger of radio, phonograph, and theatre interests by a leading group of the industry will, undoubtedly, result in similar alliances on the part of the other radio manufacturers. There can be no practical monopoly of any artistic effort and, undoubtedly, in the prospectively combined fields, we

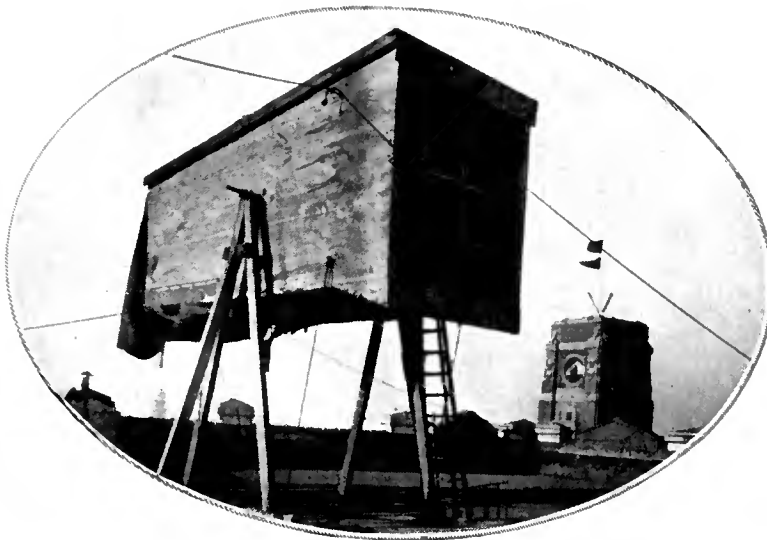

NEW SUPER-DIRECTIONAL HORN

The huge loud speaker illustrated above was developed by the Victor Talking Machine Company, Camden, N. J., and was designed to have marked directional characteristics. The horn is used to remove the hazards of landing dirigibles by providing a means of communicating directly with the ship while it is in the air. Successful results have been obtained in tests with the U. S. Navy Dirigible J-4 flying at 1500 feet over the Victor building.

will see competition of a character similar to that now applying in our more limited radio spectrum. The Radio Corporation activities, it appears to us, are only an example which will be followed by the entire industry in time. We also regard it as likely that, although patents may be an important part in the Radio Corporation structure, by the use of alternative methods or by licensing, a competitive field will be built up.

RESULTS OF UNIFICATION

TO THE radio manufacturer, the combination of these now separated industries promises an immensely increased volume of business and less seasonal fluctuation in production. To the home user of radio equipment, it will offer a more versatile source of entertainment of both aural and visual character. To the artist, it means greater opportunity to participate in a much wider range of activity, instead of restriction to a single field of entertainment, such as recording, radio, screen, or theatre. The unit of sale in radio equipment will rise manifold, and a billion dollar industry will soon appear. Every element of the industry will enjoy greater prosperity, proportionate to the greater diversity and service which it renders.

WGY Protests New Allocation Plan

THE most vociferous objections to the allocation plan have been advanced by WGY, which has been allotted a "daytime only" channel, which it may use up to the point that it interferes with KGO. Under the Commission's definition of sunset, this is three hours after sunset in the East, limiting WGY to transmissions up to about eight P. M. in winter and nearly eleven P. M. in summer. If KGO stands by for one hour after sunset, WGY gains most of the important hours when it serves its more distant listeners. The Commission points out, in answer to WGY's protests, that the First Zone, and particularly New York State, has more than its share of powerful stations and that there is one station of 30,000 watts and one of 50,000 watts within a hundred and fifty miles of WGY. Certainly, if the principle of equitable division among zones and subdivision of zone quotas according to states by population is to be ob-

served, there must be time sharing of one form or another on the part of at least one of the powerful stations in the First Zone with a station in another zone, so long as there are but eight exclusive channels per zone. WGY was selected for such sharing, no doubt, because it is not the original source of chain programs but acts principally as a relay station. Had WJZ or WEA-F been selected for sharing with a Pacific coast station, the effect would have been a great hardship upon the largest broadcasting audience in the world.

WGY HAS NATIONWIDE POPULARITY

WGY has pointed out that it is one of the pioneer stations with the most widespread audience of any station in the United States. RADIO BROADCAST's questionnaires certainly support the contention that WGY has the most enthusiastic "distance" audience of any station in the country. The requirements of equitable distribution are, however, inescapable. The exclusive channels of the First Zone cannot be assigned exclusively to chain stations or only to those within service range of New York City. The only alternative offered the Commission is to suggest a time-sharing arrangement by WGY with one of the New York stations, either WJZ or WEA-F. While this might be satisfactory to WGY, it certainly would be a blow of such serious proportions to New York listeners that it accounts for the fact that the Commission did not consider that course. The original engineers' plan, calling for fifty exclusive channels, provided room not only for WGY in the First Zone but better allocations for additional leading stations in all zones. Reduction of the cleared band to forty channels has complicated greatly the problem of providing adequately for all the good stations in all the zones.

One way out of the present situation might be a more liberal definition of "sunset." The Commission has ruled that daytime stations shall close down at the average time for sunset during a given month, at the point where the western station, subject to interference, is located. However, night broadcasting conditions do not prevail immediately upon the setting of the sun, but only after quite complete darkness. Therefore, the same sundown regulation as is used for the lighting of lights on motor cars may be more

suitable for broadcasting regulation. The addition of an extra evening hour at such peak times as ten and eleven P. M. would greatly lighten the economic burden now placed upon stations limited to daytime broadcasting. We urge that experiments be made to determine the proper time for establishing an official broadcasting sunset, because we believe this offers a loophole for improving the position of the worthy stations, now compelled to sign off just at the hours when they begin to have a fighting chance to make enough revenue to meet their expenses.

The Chicago stations which protest and ask for better channel assignments do not receive much sympathy from the average broadcast listener. Chicago stations have dominated the dials for too long a time in the memory of the broadcast listener to cause anything but glee when it is announced that the Commission has somewhat reduced the proportion of other territory assigned to stations in that city. Chicago has had its way about radio long enough and it will be a relief to listeners, who like dial twisting, to find something other than Chicago stations on the clear places.

Reasons for the 300-Mile Chain Regulation

THE regulation of the Commission, requiring that the same program shall not be duplicated in the exclusive channels by stations separated by less than three-hundred miles, has, for the time being, been waived, pending further investigation of the subject. Some months ago, in considering the problem of the frequent duplication of chain programs in the few clear channels, we pointed out that an ideal solution lay in limiting the number of exclusive channels assigned to stations of the same chain to four or five widely separated points, requiring that the bulk of chain broadcasting be conducted on regional rather than nationally clear channels. In practice, however, such regulation leaves an insufficient number of high-grade, independent stations, now carrying non-chain programs, to fill the clear channels thereby freed.

Some form of regulation is necessary, however, if the real objective of the clear channel is to be accomplished. The distant listener, beyond the high-grade service range of any broadcasting station, depends upon the nationally cleared channels for his program service. If he finds all stations within his range on these cleared channels radiating the same program, the fundamental objective of giving the rural listener the best broadcasting service and the greatest variety through cleared channels is not achieved. It was such a consideration which caused the Commission to pass the 300-mile separation regulation. The principal reason that the regulation adopted failed is that there is an insufficient number of high-grade independent stations to fill the cleared channels; not that there is anything fundamentally wrong with the regulation itself.

The Fight for Short-Wave Allocations

SECRETARY of War Dwight S. Davis has requested the Federal Radio Commission to set up a new amateur band between 5000 and 10,000 kc. This proposed band is to be used for amateur work in cooperation with Army radio stations. Oldtimers will remember that one of the first broadcasting stations in New York was WVP, operated under the supervision of the Army with the cooperation of a committee of amateurs. This station did its

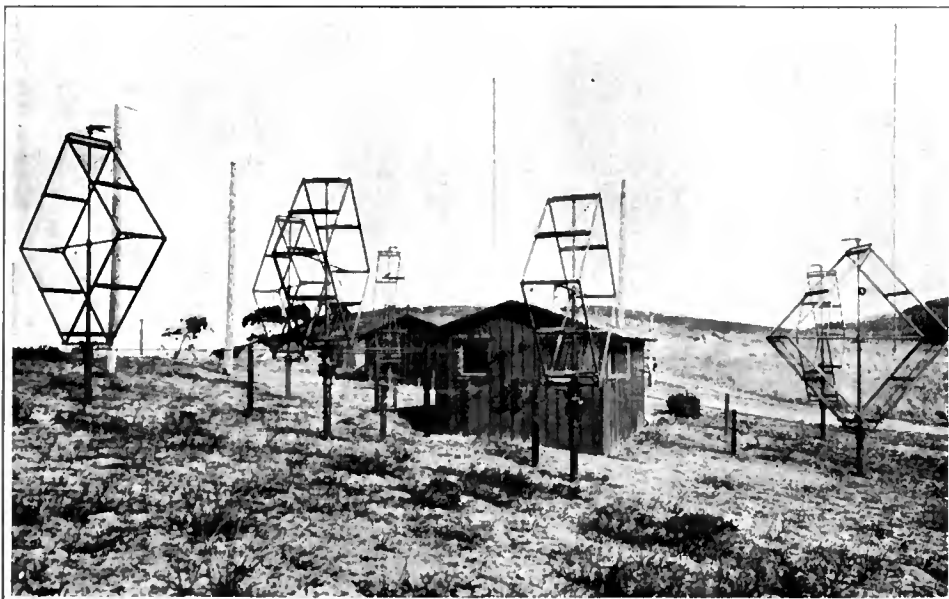

VIEW OF SAN FRANCISCO RECEIVING STATION AT DALY CITY, CALIFORNIA, SHOWING ROTABLE LOOP AERIALS. THIS STATION IS OPERATED BY THE FEDERAL TELEGRAPH FOR THE RECEPTION OF MARINE SIGNALS

share in the early days to introduce broadcasting to New York.

ONE of the more ambitious of applicants for short waves is the newly formed Universal Wireless Communication Company which wants no less than 116 short-wave channels. To begin its proposed service, it asks for an experimental license to operate a New York-Chicago circuit, to be followed, upon its success, by stations in fifty leading cities. There is no indication of the competence of the organization involved or its financial resources in the press dispatches. Certainly, its sponsors are not overburdened with modesty because they have the courage to ask for frequency space worth many millions of dollars.

A considerable number of non-communication companies have applied for short-wave channels. Perhaps one of the most interesting applications is that of the Montgomery-Ward Company, which wishes to link nine factory branches, three hundred existing stores, and ultimately 1500 stores by short-wave radio telegraphy. The means now used for communication purposes for this extensive group are the mails because telegraphy is too expensive for the purpose.

If a rental had to be paid the Government for the use of a channel, proportionate to its worth, it is unlikely that many of the private services now contemplated would be undertaken. The situation with respect to short waves is exactly similar to what would occur if we could have free telegraph lines, the only expense to the user being to furnish key and operator. Perhaps many of the Government's problems could be solved by turning over the channels in each class of service to the highest bidder. Such a process would be a shocking one to those who consider radio a democratic utopia, but it would eliminate a lot of the useless fighting now going on; limit the employment of radio to services in which it is truly superior and essential; avoid filling short-wave channels with private services, requiring discrimination against late but deserving applicants and, in addition, make radio a revenue producer for the Government.

IN SUPPORT of the Radio Corporation of America's application for 67 short wavelengths its representatives stated before the Commission that its principal purpose was to distribute 10,000 incoming transatlantic radiograms and 2000 transpacific radiograms daily. 95 per cent. of these messages are addressed to individuals and corporations in thirty leading cities, which it is proposed to link. The R.C.A.'s representative stated that Western Union, with its 25,000 offices, and Postal with its 2000, are unwilling to make satisfactory arrangements for handling these messages. The proposed radiogram forwarding business is not enormous and it seems unfortunate that a special system of communication must be set up in competition with existing nationwide systems of wire communication to handle such a reasonable amount of traffic. It is within the Commission's jurisdiction, in considering the merits of this application for short waves, to inquire why the wire facilities of the country are not available on satisfactory terms to handle the traffic involved.

With the Broadcasting Stations

A NEW departure in political programs was offered by the Democrats when they put on Irving Berlin, William Collier and Gene Buck on a coast-to-coast network, together with Fred Barrens' Democrat Orchestra. That political speeches require entertainment support has always been recognized, but this was the



THE RADIO OPERATOR OF THE COURTNEY FLIGHT AND HIS APPARATUS

Hugh Gilmour, the radio operator who accompanied Captain Courtney on his attempt to fly the Atlantic, is shown in his London home with the apparatus which he removed from the Dornier Wal flying boat when he was rescued by a life boat from the "Minnewaska" after floating in the ocean for fifteen hours.

first political broadcasting accompanied by a goodwill, musical program.

WALTER DAMROSCH, the dean of American orchestral conductors, has always found the education of children in music his happiest work. Under the sponsorship of the Radio Corporation of America, he is now enabled to carry this out on a more extensive scale than he dreamed possible ten years ago. He is directing forty-eight school concerts in four series, each series designed for a different group of school and high-school students. The first series is for children of the third and fourth grades; the second for the fifth and sixth grades; the third for seventh grade and junior high school; and the fourth for high schools and colleges. In this series, Mr. Damrosch takes up each instrument and describes its part in the spectrum of music. He also analyzes various musical themes in a carefully worked out curriculum. Schools are actively taking advantage of this meritorious educational use of broadcasting.

THE Bureau of Standards is undertaking the calibration of crystal oscillators for broadcasting stations on a moderate schedule of fees. The tremendous volume of work entailed in preparing for the new allocation requirements is, no doubt, overwhelming the personnel of the Bureau. We can count on the customary faithfulness of Bureau of Standards employees to do the job with the utmost speed consistent with the standards of accuracy which they maintain.

AN IMPORTANT addition to the Columbia chain is WBBM of Chicago which, for its power, has extremely good coverage in the central west.

WLS, the famous Sears-Roebuck station in Chicago, has been sold to the publication, *The Prairie Farmer*. E. L. Bill has been retained as its director. Inquiring persons point out that the Commission is not required to approve this sale and that it is not under obligation to grant a license to the station under the new ownership.

BY INCREASING its power to 10,000 watts, KWKH becomes the South's most powerful station.

WLW of Cincinnati and WTIC of Hartford, Conn., officially have been granted 25,000-watt construction permits and may use an additional 25,000 watts experimentally.

THE Federal Radio Commission quickly yielded to the protest of Iowa, demanding an exclusive channel, to which it is entitled under the quota arrangement of the Davis Amendment. Because of congestion in Chicago, the Commission, in its original set-up, had borrowed a channel for that city from Iowa. This is the first, but not the last, example which will show how useless the borrowing clause will prove in practice. When there is a universal shortage of any commodity, it becomes impossible to find anyone who will loan freely to others. Certainly, nobody feels inclined to make any sacrifices so that Chicago may have additional stations.

AN OPINION by Federal Judge James H. Wilkerson confirmed the right of the Federal Radio Commission to regulate wavelengths and the power of broadcasting stations under the Radio Act of 1927. This decision was rendered in Chicago in the case of Stations WCRW and WEDC, which stated that the Commission's power reduction, required under the new allocation plan, represented confiscation of property without due process of law. The effect of the decision is merely to change the scene of argument from a Chicago court to one in Washington where, under the Radio Act, such appeals must be brought.

Progress in the Field of Aircraft Radio

THE first of a more powerful type of radio transmitter installations at an important aircraft junction point is to be completed at Cleveland, Ohio, in the near future. It is of 2000-watt power and promises to give reliable radio-telephone communication with aircraft in flight for a distance of a hundred miles and many times that distance by telegraphy. The standard aircraft frequency of 335 kc. will be employed. Eleven aircraft centers, other than Cleveland, are being installed at the present time, and all of them will be in operation within the next six months.

UTILIZING 500-watt high-frequency transmitters a complete chain of stations has been established as the communications network for the Chicago-Dallas air route. The cities at which the transmitters are located are Fort Worth, Oklahoma City, Wichita, Kansas City, Unionville, and Moline.

BELLEFONTE, PA., is the location of another radio aircraft installation. This important center for air mail service will have a directive radio beacon, somewhat similar to that installed at College Park, Md. Announcement is also made of a new type of vibrating reed which is used as an indicator on the plane, in which change in frequency with temperature is practically eliminated.

Radio Abroad

A VITALLY important patent decision was made by the Comptroller General of the Patent office in England when a compulsory license was granted to Loewe Radio Company. Under this compulsory license, the Loewe Company will make three- and two-element radio valves at license fees of 10 s. and 7 s. 6 d. respectively, instead of £1, 17 s. 6d. and £1, 5s., heretofore asked by the Marconi Company. In the decision of the Comptroller General, he stated that he was "satisfied that a case of abuse of monopoly rights had been established." The decision further states: "When we come to consider the scale on which the applicants hope to manufacture in this country, the Loewe valve will be recognized as offering a new advantage or utility for which it may be well worth sacrificing the superior sensitiveness which the use of reaction admittedly affords. Broadcasting has become a feature of our national life and a commercial policy which excludes large sections of the public from its full enjoyment is not, we think, a justifiable policy.

"The Marconi Company have secured a dominant position by gathering together in their own hands a large series of patents which, taken collectively, cover almost all broadcasting receivers of an efficient character. It is to be remarked that not one of the five patents now in question is for an invention originating with the Marconi Company. Three of them are American, one is French and one is German in origin.

"It is a kind of super-monopoly. The applicants cannot seek alternative terms from competing monopolists. They are absolutely in the hands of those who have gathered together this far-reaching aggregation of monopolies."

THE British Broadcasting Company's educational curriculum includes literary readings in French, German, and Latin from biographical sources, and a wide range of subjects presented in English on literary, historical, geographical, and musical subjects. This educational program is summarized completely in a brochure on the subject which should interest ambitious American program directors.

THE League of Nations announces that its plan of establishing a powerful radio-telegraph station has advanced to the point

that it has now purchased a 50-kilowatt transmitter which will be operated, in normal times, by Radio Suisse. The station and its personnel may be taken over by the League, upon notice, in emergencies.

THE Government of Australia, under a new law, has taken over the ownership, equipment, and facilities of broadcasting stations of the Class "A" type. A system somewhat similar to that now established in New Zealand is being adopted for the control of broadcasting.

A COMMISSION has been appointed in Canada with a view to laying plans for the establishment of a national radio system, similar in character to the British Broadcasting Company. The commission will study the situation, not only in Canada but in Great Britain and the United States. Naturally, the owners of broadcasting stations are opposing the move.

In the Visual Broadcasting Field

COMMISSIONER H. A. LAFOUNT is reported as advising stations in his zone, interested in visual broadcasting, that, "In my opinion, the Commission will shortly issue orders for the regulation of television and picture transmission, particularly in the broadcast band. I, therefore, suggest that you defer the purchase of any equipment or the making of any investment until such action has been taken."

If restrictive regulation must be applied to this experimental art to the discouragement of those who are risking their time and money in so problematical a field, it would be a good idea to get it over with. There is no known reason for regulation at this time because picture broadcasting is causing no trouble of any kind, but the Commission has so often and so repeatedly thrown the shadow of threatened regulation upon it that progress in extending picture broadcasting has been totally stopped. If the new field must be stifled by the Commission, the sooner it is done the better, because all the money, so far

courageously spent by experimenters, is practically a total loss should the Commission pass any serious restricting regulations. Further waste in experiments may as well be stopped, sooner rather than later, and protracting the agony is not in the least helpful.

A VERY fine publicity story emanated from WGY, following the broadcast, on the evening of September 11, of the radio play from their studio. The television transmitter was working on the occasion. The story stated that synchronization of speech and vision was perfect, but there were no comments as to the character of the images received. Those, technically acquainted with the subject, were inclined to smile at the statement that perfect synchronization was accomplished, not because there was any doubt that it had been done, but because it would have been wonderful if anyone discovered a practical means of transmitting speech and television out of synchrony under the conditions involved. A statement by Dr. Alexanderson, who is receiving WGY's transmissions at Lake George, a distance of two-hundred miles, reported trouble from a mirage or delayed image. Television may prove useful in securing data with reference to the heaviside layer.

THE Experimenter Publishing Company has issued a magazine which was to appear under the title *Television*. The application for the injunction was, of course, denied by the New York Supreme Court. Somebody ought to publish a list of patented words.

News of the Radio Industry

IN URGING industry support of the R. M. A. patent pooling plan, Le Roy J. Williams of that Association pointed out that the automobile industry, which solved its patent difficulties by means of an identical scheme, did not find a single patent basic. The R. M. A. plan, as our readers will remember, provides for the pooling of non-basic patents at the option of their holders, and permits patent holders to exempt so-called basic patents from the pool. The argument, however, does not hold good for the radio industry because there are many patents of a decidedly basic character still in force. The pooling of non-basic patents is of negligible importance.

A RECENT statement of the R. M. A. innocently rises to the point of humor when it seeks to throw aspersions on the accurate and comprehensive statistics which the National Electrical Manufacturers' Association has issued with the cooperation of the Department of Commerce. The R. M. A. now proposes to go into the statistics business also, utilizing agencies of a character undisclosed to assist it. "The study of available, but incomplete statistics, largely estimates, is being made by the Committee which will present recommendations to the R. M. A. Board of Directors for the development of real statistics which are reliable and may be of actual service to all branches of the radio industry." Silly publicity of this character certainly does not reflect glory upon those who issue it.—E. H. F.

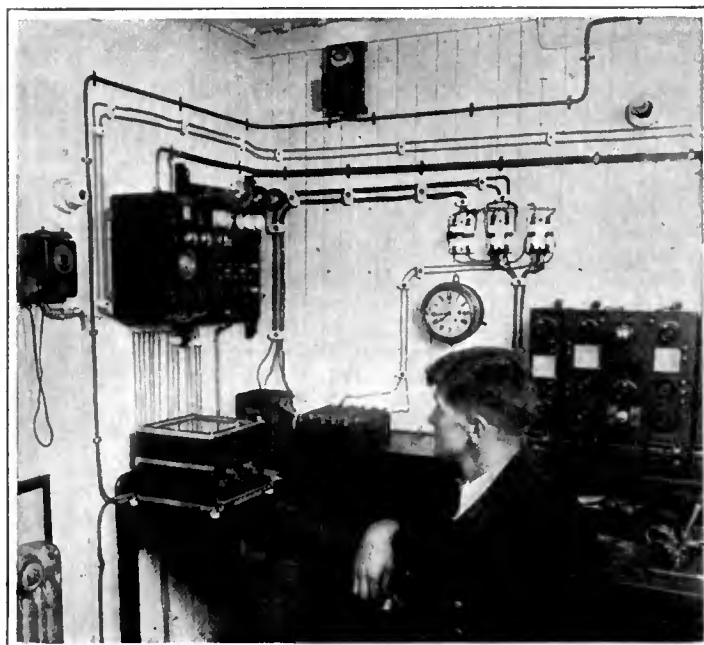

NEW AUTOMATIC SOS RECEIVING APPARATUS

The S. S. "Cedar Bank" recently has been equipped with Marconi apparatus for automatically receiving SOS signals. The signals are received by the three-tube regenerative set shown on the left, and below the receiver is the selector relay which rings bells, in the radio room, on the bridge and in the operators' stateroom, whenever an SOS signal is picked up.



FRONT VIEW OF "SKYSCRAPER" RECEIVER

The "Skyscraper" Screen-Grid Receiver

By CLIFFORD DENTON

Ferranti, Inc.

FOR a long time the neutrodyne type of receiver, consisting of a two-stage neutralized radio-frequency amplifier using 201A-type tubes, a non-regenerative detector and a two-stage audio-frequency amplifier, justly has been considered an excellent set—sensitive, selective, and easily controlled. The receiver described in this article has these plus some additional good characteristics. This set uses two stages of r.f., detector and a two-stage audio amplifier, and to this extent is to be likened to a neutrodyne—but here the similarity ends.

In this receiver two 222-type screen-grid tubes are used in the r.f. amplifier and, as a result, it becomes unnecessary to neutralize the r.f. circuits and greater amplification is obtained. The use of the screen-grid tube in the r.f. stages makes it essential that shielding be used and that all the plate and filament circuits be bypassed and filtered to prevent common coupling between the various circuits, which would result in oscillation. As part of the shielding, it is recommended that Remler tube shields be placed over each of the 222-type tubes.

Starting with the antenna connection we will review the circuit arrangement used in this receiver, and in this way we will be able to bring to the attention of the reader the various interesting design features which the set possesses. The circuit diagram of the receiver is given in Fig. 1.

The input circuit to the receiver is arranged so that either an antenna or a loop may be used. The loop is connected to the two terminals marked "Loop" in which case no ground need be used, although a ground may be connected to the ground terminal if one desires. The antenna connects to the first coil L_1 , through a small 0.0001-mfd. fixed condenser, C_1 . The switch SW_2 adapts the set for use on either a short or a long antenna, and, when the set is put into operation, reception should be checked on both positions of the antenna switch. In locations where there are several near-by broadcasting stations and a selective receiver is essential, the antenna switch should be thrown to terminal No. 1. With the antenna switch in this position the set is very selective; if the switch is thrown to terminal No. 2 the volume will increase but

the set will lose some selectivity. In out-of-town locations, where very sharp tuning is not required, the set generally will give most satisfactory operation with the antenna switch on terminal No. 2.

The output of the tuned circuit L_1C_2 feeds the grid circuit of the first 222-type tube which in turn feeds into the r.f. transformer consisting of L_2L_3 . This transformer is wound on a threaded hard-rubber tube. The plate coil is wound first with a small-size wire in the bottom of the grooves and on top of this primary winding the secondary is laid, the secondary wire being of a

type tubes. The output transformer, T_3 , should be of a type designed for use with the particular loud speaker which is to be used with the set. The designers of the receiver, feeling that many experimenters might have available an audio amplifier and, therefore, desire only to construct the radio-frequency and detector circuits, have shown the jack J_2 in the plate circuit of the detector. If a separate amplifier is to be used it should be connected to this jack.

As we mentioned in a previous paragraph all the battery circuits of the receiver have been filtered carefully in order to prevent common coupling which is often the cause of oscillations and motorboating. The screen-grid circuits of the two r.f. tubes are filtered by the 10,000-ohm resistors, R_2 and R_3 and the condensers, C_5 and C_6 . The plate circuits of these tubes are filtered by resistors R_4 and R_5 , each with a value of 50,000 ohms, and the by-pass condensers, C_7 and C_8 . The detector circuit is filtered by the 4-mfd. condenser C_9 and the resistor R_1 . Filtering in the detector circuit is especially important since even a small amount of coupling at this point will affect the characteristics of the audio amplifier and either make it distort or hum badly, and in some cases the coupling may be sufficient to make the audio amplifier oscillate.

Three filter circuits are located in the audio amplifier. The grid circuit of the first audio-frequency amplifying tube is filtered by a 2-mfd. condenser, C_{10} , and a 50,000 resistor R_7 . The plate circuit is filtered by a 20,000-ohm resistor, R_8 , and the condenser C_{11} with a capacity of 2 mfd. The third filter circuit is located in the grid circuit of the input push-pull transformer, T_2 , and it consists of a 10,000-ohm resistor, R_9 , and the condenser, C_{12} , whose capacity is 2 mfd. [Push-pull amplifiers frequently have a tendency to oscillate especially if the power tubes have slightly different characteristics. If the amplifier does oscillate it can be overcome by placing a 50,000-ohm resistor between the center-tap of T_2 and R_9 , in the grid circuit of the input push-pull transformer. This resistor should not be by-passed. The use of this resistance will not in any manner adversely affect the quality. Editor.]

THE receiver described in this article is a development of Robert Arnold, in association with the laboratory of the Ferranti Company in the United States. The set was examined and tested in operation in New York City by a member of the staff of RADIO BROADCAST Laboratory and it performed very satisfactorily. The set is quite selective and the fidelity is excellent. RADIO BROADCAST will be pleased to hear from those who undertake the construction of the set.

Constructional data is not given in this article for complete information of this sort may be obtained directly from the Ferranti Company.

—THE EDITOR.

size such that it lays on top of the groove. The turns ratio is 1 to 1. The coils are mounted on a standard four-prong base and plug into sockets mounted on the sides of the shields, as indicated in the picture of the receiver.

This secondary, L_3 , of this transformer feeds into the second radio-frequency tube whose output circuit supplies energy to the next transformer consisting of L_4L_5 ; this transformer is similar in construction to the preceding one. A C-bias detector is used; the plate is supplied with 90 volts through the 50,000-ohm resistor, R_1 , and minus 6 volts is used on the grid. The output of the detector goes to the first audio transformer, T_1 , across the primary of which is connected a jack, J_1 , to which a phonograph pick-up unit may be connected. The output circuit of the audio amplifier is push-pull with 171A-

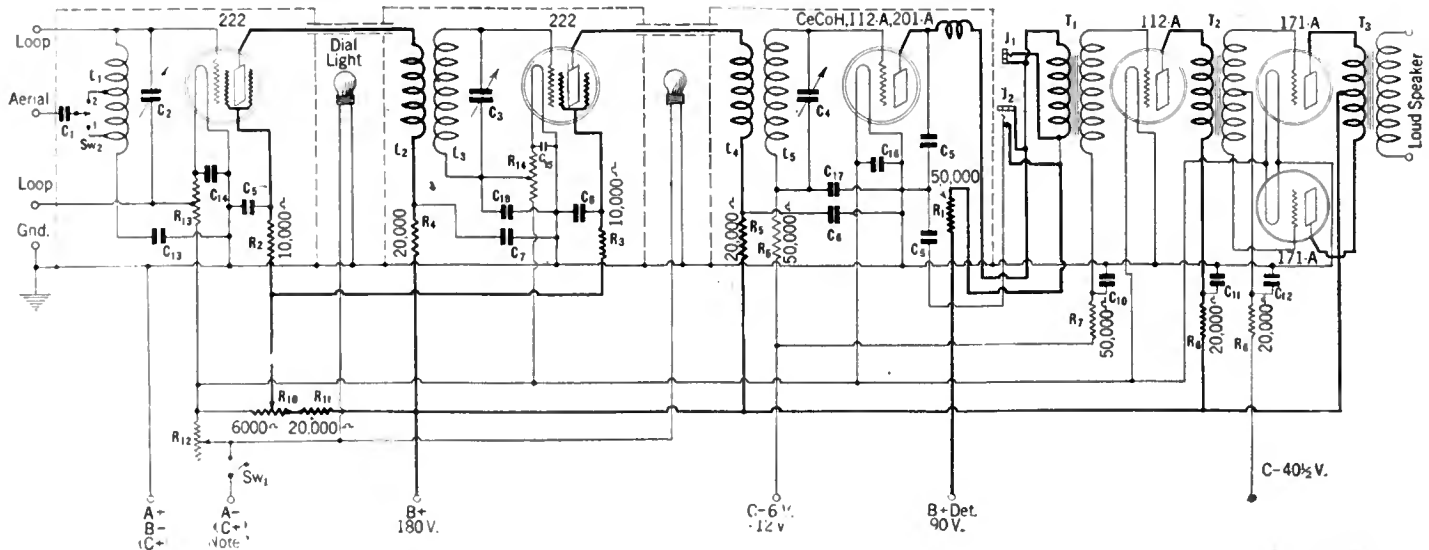

FIG. 1. COMPLETE SCHEMATIC DIAGRAM OF THE "SKYSCRAPER" RECEIVER

The values of resistance used in the filter circuits are such that both of the r.f. tubes and the first audio tube may be supplied with 180 volts from the power supply, and the filter resistance will reduce this voltage to the correct value for the operation of the particular tube. An example will make this clear. Consider the first audio stage, in which socket is recommended the use of a 112A-type tube. The d.c. plate resistance (not the a.c. plate resistance) of this tube is about 20,000 ohms. This 20,000-ohm plate-circuit resistance is in series with a 20,000-ohm filter resistance, R_6 , across 180 volts. Therefore, half the voltage will appear across the tube and the other half across the filter resistance. Therefore, there will be about 90 volts on the plate of the 112A-type tube.

Volume is controlled in this receiver by varying the potential applied to the screen grids of the r.f. tubes, this adjustment being accomplished by R_{10} , a 6000-ohm potentiometer. In series with this 6000-ohm potentiometer is placed a fixed resistance, R_{11} , with a value of 20,000 ohms so that not more than the rated value of 45 volts can be applied to the screen grids.

On the front panel of the receiver are four controls, besides the on-off switch. The two small knobs at the lower-right and left-hand corners are the filament rheostat and the volume control, respectively. The drum dial on the left tunes the antenna condenser, C_2 , and the right-hand dial tunes the other two condensers, C_3 and C_4 , which are ganged together.

For the past several months development work on the "Skyscraper" receiver has been in progress in the laboratories of the Ferranti Company. For this reason the writer feels certain that those who construct the set will obtain as satisfactory performance as he has from the various models which have been undergoing tests. Optimum performance can be assured only by following as closely as possible the arrangement of apparatus illustrated in the pictures on these pages and in the wiring layouts supplied with the construction booklet. For this reason it is recommended that set builders, who contemplate building the receiver, send for this booklet. If, after the construction has been completed, the set does not perform in an altogether satisfactory manner the wiring should be checked carefully and the various tubes should be tested. It is also a wise plan to examine the B power-supply device, as poor results may be caused by incorrect plate voltages.

LIST OF PARTS

THE apparatus used in constructing the model of this receiver illustrated in these pages is given below. The total cost of the parts listed is \$95.00. The builder may substitute electrically equivalent parts.

The last four items in the list, and also the tuning coils, are especially designed for use with this receiver, and may be obtained by writing directly to the Ferranti Company. Those who desire to construct this set can also obtain a booklet giving complete constructional data from the Ferranti Company for \$1.00.

The list of apparatus follows:

- C_1 One Tiny-Tube fixed condenser, 0.0001-mfd.;
- C_2, C_3, C_4 Three Remler SLW condensers, 0.0005-mfd.;
- $C_5, C_6, C_7, C_8, C_{13}, C_{14}, C_{15}, C_{16}, C_{17}, C_{18}$ Ten Tube by-pass condensers, 0.5-mfd., type 300;
- C_9 One Tube condenser, 4-mfd., type 240;
- C_{10}, C_{11}, C_{12} Three Tube condensers, 2-mfd., type 202;
- L_1, L_2, L_3, L_4, L_5 Three Ferranti tuning coils, "Skyscraper"-type;
- L_6 One Hammarlund r.f. choke coil, type RFC-85;
- R_1 One Tube fixed resistor, 50,000-ohm, 2-watt;
- J_1 One Yaxley jack, open-circuit;
- J_2 One Yaxley jack, closed-circuit;
- R_2, R_3, R_4 Three Tube resistors, 10,000-ohm, 2-watt;

- R_4, R_6, R_8, R_{11} Four Tube resistors, 20,000-ohm, 2-watt;
- R_6, R_7 Two Tube resistors, 50,000-ohm, 2-watt;
- R_{10} One Carter midget potentiometer, type MW-6M;
- R_{12} One Carter rheostat, 6-ohm, type 506;
- R_{13}, R_{14} Two Carter resistors, 15-ohm, type J-5-15;
- T_1 One Ferranti transformer, type AF-5;
- T_2 One Ferranti transformer, type AF-5C;
- T_3 One Ferranti transformer, type OP-8C for magnetic speakers, type OP-4C for dynamic speakers;
- Two Remler tube shields, type 56;
- Three Hammarlund shaft couplers, type FC;
- Three Na-Ald sockets, type 424;
- Three Na-Ald sockets, type 428, for plug-in coils;
- Three Benjamin sockets, type 9040;
- One pair of Benjamin brackets, type 8629;
- Two National drum dials, type VF with type-28 illuminators;
- Two Carter screen-grid connectors; type 337;
- One Yaxley mounting plate and cable, 7-wire;
- Four Eby binding posts, insulated;
- Ten Lynch resistor mounts;
- Acme flexible wire in colors to match Yaxley cable, for wiring;
- One Aluminum base, 10-gauge; drilled;
- One Bakelite panel, 8" x 24" x 1/8", walnut finish, drilled;
- Three Aluminum Co. of America standard shields, drilled;
- Thirteen rubber insert rings, for feed line through base.

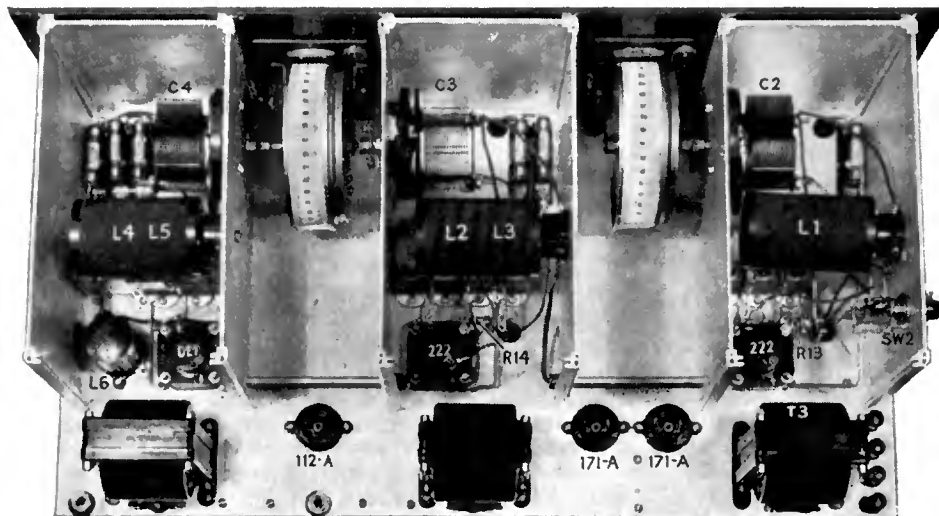

THIS PICTURE SHOWS THE EXACT ARRANGEMENT OF PARTS ON THE CHASSIS

More Data on Underground Aerials

SO FAR as we are concerned the following quotation from a letter from our good friend Dr. G. W. Pickard closes the subject of trick and underground antennas:—

"On page 259 of the September issue of RADIO BROADCAST I notice an appeal for definite quantitative data on the underground antenna. Probably by this time you have found the various references necessary, but in case you have not, I'll give some of the desired facts.

"As you know, there are underground antennas and antennas. Some of these consist of plates or coils of wire, variously insulated, but aside from the sucker type of radio fan, no one has taken them seriously, and so far as I am aware, no quantitative measurements have been made. But the real, more-or-less-useful type of underground antenna, consisting of a long, straight insulated wire buried at a slight depth in the ground, is the subject of a considerable technical literature, and its reception characteristics are quite well known.

"First, consider 'Short-Wave Reception and Transmission on Ground Wires (Subterranean and Submarine)' by A. Hoyt Taylor, *Proceedings I. R. E.* Vol. 7, No. 4, August, 1919. Taylor points out that the buried wire antenna is strongly directive, receiving signals best in the direction of its length, and but feebly from directions normal to the wire. He also explains that reception is possible because of a tilt in the wave-front, which gives a component of the electric vector parallel to the wire.

"Next, take my paper, 'Static Elimination by Directional Reception,' *Proceedings I. R. E.*, Vol. 8, No. 5, October, 1920, wherein it is explained that if static and signal come from different directions, properly oriented directional aërials will eliminate more static than signal.

"Finally, consult 'The Wave-Front Angle in Radiotelegraphy' by L. W. Austin, *Washington Academy of Science Journal*, pages 101-106, March 4, 1921, wherein it is shown that waves are slightly tilted forward in the direction of propagation, this tilt being small and of the order of 0°-3°.

"It is obvious without going further into the literature of the subject that buried wires often give better signal-static ratios than does the conventional open antenna, simply because they receive directionally.

"Now for a numerical answer to RADIO BROADCAST's question; what is the relative signal strength of a fifty-foot wire in the open, and the same length of wire buried? If the wire in the open is truly vertical, and the earthed wire is hori-

zontal and but lightly covered with earth, reception on the buried wire will be somewhere between 0 and 3 per cent. of that on the vertical wire, depending upon soil resistance and the consequent tilt of the wave. If the wire is buried quite deeply, both theory and Taylor agree that the wave tilt will increase, and hence a somewhat better signal will be obtained on the more deeply buried wire. If you really wish to pursue this matter to the bitter end, that is, literally run it into the ground, see *Wireless Telegraphy* by Zenneck, McGraw-Hill, 1915, particularly pages 260-262 and Figs. 310-317 showing examples of tilted waves for different soil constants.

"You see, there is no mystery, no magic about this matter. There is no division of the wave from the transmitter into two distinct parts, one traveling under and the other over, the earth's surface. There is no inexplicable filtering action in a layer of dirt which will strain the static out and let the signal through. A long buried wire is merely an inefficient but directional antenna, and, if it can be aimed at the signal and not at the static, it will give a favorable signal-static ratio.

"But more power to you in your attack upon the thousand and one fake contraptions which grow like weeds upon our unfortunate roofs, burrow foolishly in the ground and litter the tables of the uninformed fan. I am afraid an appeal to reason will not reach effectively the class you would protect, therefore, the best way

would be to make fun of these fakes. With wire cones, triangles and other Euclidian-looking objects on the roof, weird tangles of wire in pits on the front lawn, Geppert and other dingusses guarding the radio receiver, a poor, puzzled radio wave must scratch its head and wonder how it would ever get in."

Is a 112 Tube Needed in the First stage?

to use a 112-type tube in the detector socket because of its low output impedance. The object is that under these conditions the first audio transformer works out of a tube whose impedance is, ostensibly, 5000 ohms, instead of 12,000 ohms for the 201-A. Therefore, the articles argue that the low-frequency response will be better. We have often suspected this to be a piece of nonsense, and recent tests made in the Laboratory by Howard Rhodes on a two-stage Sangamo amplifier have proved our contention.

Little or nothing has been said about what happens to the high-frequency response of an amplifier when the impedance out of which it works is changed. It seems to be assumed tacitly that nothing happens, or if it does, the difference does not matter. This may be part of the general negligence on the part of amplifier designers to consider the high frequencies as unimportant, occasioned without a doubt by the unreasonable

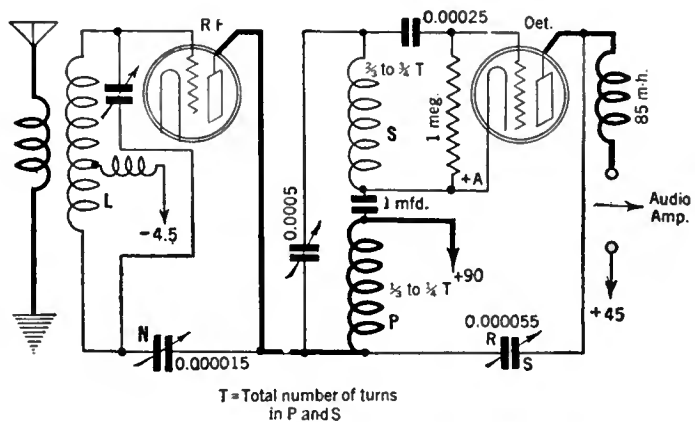

FIG. 5. THE IMPROVED "LAB" CIRCUIT RECEIVER

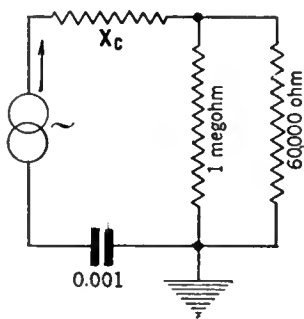

FIG. 3

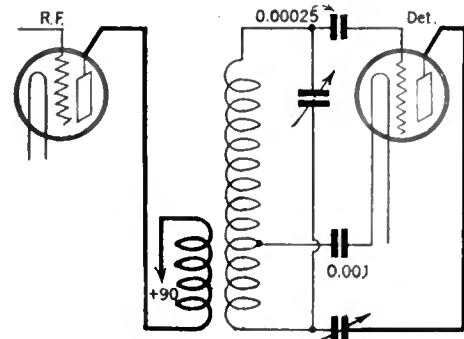

FIG. 4

demand on the part of listeners for low-frequency tones all out of proportion to their natural values. Mr. Rhodes's figures (Table II) show that working a good amplifier out of an impedance for which it was not designed may ruin its characteristic.

TABLE II

Rp ohms	Frequency cycles				
	60	1000	2000	4000	6000
5000	-1.7	0	+1.3	+2.8	+2.6
10,000	-1.7	0	+0.6	0	-1.3
20,000	-2.0	-0.5	-1.1	-3.5	-5.2
30,000	-2.3	-1.0	-3.2	-8.0	-8.6

TU

The amplifier consisted of two Sangamo type-A transformers, a cx-327 first-stage and cx-350 second-stage tube. The output device consisted of a General Radio Type 587-D which is made up of a 15-henry choke and two 2-mfd. condensers. The current into 4000 ohms was read while the input voltage was kept constant. The table gives the necessary data on the measurements. The current at 1000 cycles when the amplifier worked out of 10,000 ohms was taken as a zero level; all other adjustments of frequency and input impedance are compared to this value. Thus, at 60 cycles and worked out of 5000 ohms, the amplifier is down 1.7 TU compared to 1000 cycles when worked out of 10,000 ohms.

The amplifier has the best characteristic when worked out of 10,000 ohms, and it is assumed it was designed with this impedance in mind. Working it out of 5000 ohms causes a rise at the high frequencies where the secondary capacity begins to resonate with the leakage reactance of the transformer. Perhaps this is because lower input resistance is equal to lower reflected resistance in this resonant circuit so that the resonance becomes more pronounced. This theory is borne out by the fact that many amplifiers, which are perfectly stable when operated out of 10,000 ohms, begin to oscillate badly at 5000 or 6000 cycles when worked out of low impedances.

The Sangamo amplifier begins to fall off when worked out of 20,000 ohms but is still much better than many when worked out of the impedances for which they were designed.

The truth of the matter is that a well-designed transformer is engineered with some particular input resistance in mind. When worked out of this resistance the characteristic will be the best, if this resistance is something else the characteristic goes bad. If the resistance is 5000 ohms a 112-type detector tube will give better over-all frequency response; if it is 10,000 ohms a 201-A detector will be better.

The question remains, what is the output impedance of an average detector circuit? Who knows?—KEITH HENNEY.

A Test Set for the Radio Service Man

By B. B. ALCORN

The second installment of a series of articles relating the experiences of a radio service man

THIS is the second article on practical service problems by Mr. Alcorn. In his first story, the author discussed what seemed to him the ten leading service troubles, analyzing some of them in detail. This one deals with short circuits and the "case histories" represent actual and most interesting experiences which should be useful not only to those who have occasion to service or use the particular sets referred to, but also to those doing service work on almost any set. Surprisingly little really helpful data has appeared in print on service problems. It is our hope that these articles by Mr. Alcorn, and other similar articles which we may publish, will in a measure fill this real need.

—THE EDITOR.

of all parts to be in order, except that the B potential did not reach the plates of the tubes. After considerable checking, the trouble was located in the battery cable, but not in the place where one would normally expect to find it. The A+ wire in the battery cable of this receiver is fitted with a lug for connection with the storage battery, and the B— wire is connected with the cable in this lug. In some way the B— wire had become loose, and an oxide had formed which insulated the wire from the cable. When this difficulty was repaired no further trouble was experienced with the receiver.

GOOD EQUIPMENT NEEDED

IN THE servicing of radio receivers a repair man is lost without the proper tools and testing equipment. Both of these items are of equal importance and their selection deserves the most serious consideration. With a well-designed portable test set it is possible to locate most all causes of trouble in a fraction of the time that would otherwise be required, and, if a complete set of tools is available, the receiver often may be repaired in the customer's home. However, when equipping himself with tools and test apparatus the service man should always consider the equipment from the viewpoint of portability and convenience.

In addition to its utility value a service man's equipment accomplishes another very important result; namely, it creates a favorable impression in the mind of the client, and this is very important. Therefore, when building or buying portable equipment it is wise to consider its appearance as well as its usefulness.

IN SERVICING radio receivers repair men and radio dealers are confronted constantly with mystifying problems which tax their ingenuity to the extreme. In some cases several hours of experimenting may be necessary before it is possible to locate the trouble and start work on the repair, whereas other times an unusually baffling condition may be cleared up accidentally in a few moments. The writer does not wish to infer that he has found the solution difficult in all, or even a majority, of the problems in radio servicing, for this is not the case. On the contrary, the owner's description of the receiver's performance often permits one to diagnose the trouble, and other times it is possible to analyze the difficulty by merely turning the tuning controls for a few moments. However, there are a sufficient number of unusual ailments which a receiver is apt to contract to make this line of work full of interest.

In last month's article of this series the writer described several unusual experiences which he has had in locating troubles caused by open circuits. It is admitted that the difficulties cited were out of the ordinary, but they serve to point out the type of work a service man must be prepared to tackle. In all probability open circuits of the types described may never be experienced by the reader, but they are typical of the peculiar problems which present themselves every day. While on this subject there is one new case of open-circuit trouble which may be of interest.

The writer was called upon to repair an Atwater Kent Model 35 receiver, and after testing the various circuits it was found that there were a great number of open circuits. Both audio transformers were burned out, the grid suppressors were open, the primary windings of the radio-frequency transformers were defective and, in addition, several by-pass condensers were blown out; in fact the set was almost a total wreck. However, after all of these parts had been repaired or replaced the set still refused to function, although the usual tests showed the continuity

There are a number of excellent test sets available on the market, and, if the service business will stand the strain on its pocket-book, one of these instruments is an excellent investment. Such apparatus is now being made by Hoyt, Jewell, Supreme Instrument, Weston, and other instrument manufacturers. The writer recently had an opportunity to experiment with the test set made by the Supreme Instrument Company, and, while it is rather expensive, it is as complete an outfit as could be desired. The set is designed especially for use in the field, but it is also excellent for work in the laboratory. It consists of an oscillator, a wavemeter, a calibrated variable condenser, and a power-supply circuit which operates direct from the a.c. line. The set is housed in a neat case which also provides space for carrying tools, tubes, and enough supplies to meet the usual requirements. It may be considered a portable laboratory.

Unfortunately most service men cannot consider purchasing elaborate test equipment of the type referred to in the above paragraph, because of the high cost of such apparatus. However, it is possible to build a very satisfactory set-checking device at a considerable saving in expense. It is true that such a set tester may not be quite as versatile as a commercial product, but it may be constructed so that it is satisfactory for most purposes. The set checker designed by the writer will indicate short circuits, open circuits, and the general condition of tubes in both a.c. and d.c. receivers, and it is made up of meters that every service man should own. Of course, if high-grade meters are used the cost may be as high as \$40, but this is considerably less than the average commercial outfit.

PARTS NEEDED

A LIST of the apparatus required for the construction of the set checker is as follows: One double-range panel-mounting high-resistance d.c. voltmeter, 0-8 and 0-200 volts;

- One panel-mounting d.c. milliammeter, 0-100 milliamperes;
- One portable triple-range a.c. voltmeter, 0-4, 0-8 and 0-150 volts;
- Two Benjamin sockets, ux-type;
- Nine Carter tip jacks;
- Two single-pole, double-throw push-button switches;
- One double-pole double-throw switch;
- One double-pole single-throw switch;
- One wooden case (large enough to provide space for accessories);
- One bakelite panel.

The accessories used with the test set follow:

- One set of test prods;
- One socket adapter, UX199 to UV199;
- One socket adapter, UV199 to UX199;
- One socket adapter, UX199 to UV-201A;
- One Jewell ux socket adapter, type-521;
- One test cord (made by connecting two UX199 bases by six feet of four-wire battery cable).

The complete schematic diagram of the set tester is given in Fig. 1. The portable a.c. voltmeter is not



THE AUTHOR'S TEST SET

connected directly in the tester, but it is a necessary piece of equipment which should be on hand at all times. One of the sockets called for in the list of parts is connected in the position indicated by the tube in the diagram; the four wires marked "test plug" are connected to the terminals of the second socket. The notations on the drawing indicate many of the ways in which the tester may be used, but a few additional pointers may be of interest.

In checking a battery-operated receiver with this set tester it is best to start by removing each tube of the set in turn and inserting it in the tube sockets of the tester, the test plug socket of the tester being used for the test cord which is also plugged into the empty socket of the receiver. Next, throw the double-pole switch to one side, but change it quickly to the other side if the d.c. voltmeter is incorrectly connected, i.e., if the needle tends to move in the wrong direction. With the tester connected in this manner the milliammeter will indicate the condition of the circuit under test; if the deflection of the meter is correct for the tube used, it is necessary to assume that the circuit and tube are operating properly, but a large deflection indicates a short circuit and zero deflection indicates an open circuit.

After the above check has been completed it may be necessary to make further tests in order to locate the exact position of the opened or shorted circuit. In this connection it is interesting to note that tip jacks have been provided on the tester so that each of the meters may be used separately. When testing a.c. sets the portable a.c. voltmeter is used to measure the filament or heater potentials, and then the circuit is checked in the usual manner with the tester. It should be remembered that the d.c. voltmeter will not record the filament voltages of an a.c. set, and, therefore, the double-pole switch should be open when making the tests.

The tools and replacement equipment which it is necessary for a service man to carry with him in the field vary in different territories. In districts where it is necessary to travel a considerable distance from the shop it is essential that the equipment be very complete, and it should consist of a large assortment of tools as well as a number of replacement parts, such as transformers, condensers, etc. On the other hand, when working in a city a large kit of tools and parts is not essential. However, it is always advisable to carry a complete assortment of tubes and a few minor parts such as grid leaks, fixed condensers, amperites, etc. For city work the tools which the average service man considers it necessary to carry are a pair of long-nose pliers, a screw driver and an electric soldering iron.

AN EFFICIENT TOOL KIT

THE writer was once employed as field engineer for a well-known manufacturer, and, while acting in this capacity, he covered most of the southern states. In this work it was necessary for him to carry a very extensive kit of tools in order to be able to meet all conditions. In this particular case the tools were carried in a case with straps for each tool, thus making it difficult to lose equipment as each strap had to be filled before leaving the scene of work. A list of the tools included in this kit is as follows: flat-nose pliers, long-nose pliers, round-nose pliers, diagonal pliers, slip-joint pliers, long-nose angle pliers, duck-bill pliers, ratchet screw driver with three blades, screw driver with screw-holding attachment, set of Stevens Spintite wrenches with detachable handle, Yankee push drill, American Beauty soldering

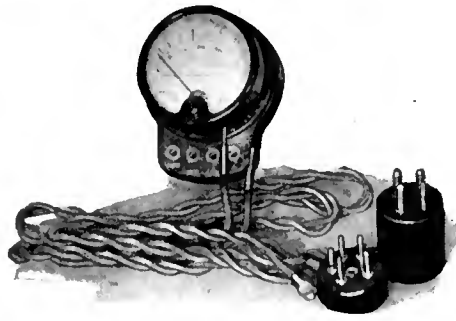

A HANDY A.C. VOLT-
METER AND TEST PLUG

iron, bits, reamers, and counter-sink bits. The miscellaneous equipment consisted of solder, soldering flux, tape, saddle tacks, lead-in strips, ground clamps, etc.

SHORT-CIRCUIT TROUBLES

TROUBLES caused by open circuits, which were discussed at length in last month's issue, are only one of the many types of difficulties experienced in the repair of radio receivers. Short circuits cause the service man nearly as much worry as the former, and they will be considered in the following paragraphs. Short circuits, it might be explained, occur in accessories as frequently as in the set itself, and they frequently are the result of carelessness or inexperience on the part of the person installing the receiver.

Short circuits due to carelessness or inexperience frequently are found in the Radiola Super Eights and the Radiola 20's. In these receivers six dry cells are connected in series parallel, and in installing these batteries a short circuit is often caused by two negative terminals touching each other, thus shorting one or more batteries and causing the set to go "dead." Much time is lost and often another set of batteries is ruined before the real cause of the trouble is discovered.

Another rather baffling short circuit, which is encountered frequently, is found in the older types of reflex receivers, such as the de Forest. Although there are few of these sets in city homes, many of them are still being used in outlying farm districts. This particular short manifests itself as an open circuit, and, when the set is tested with a set checker the results indicate a burned-out transformer. However, further testing will show that the transformer is perfect; the trouble being caused by a shorted condenser in shunt with the primary or secondary winding of the transformer. When the faulty condenser is removed the set will function but bad distortion will be experienced until the condenser is replaced.

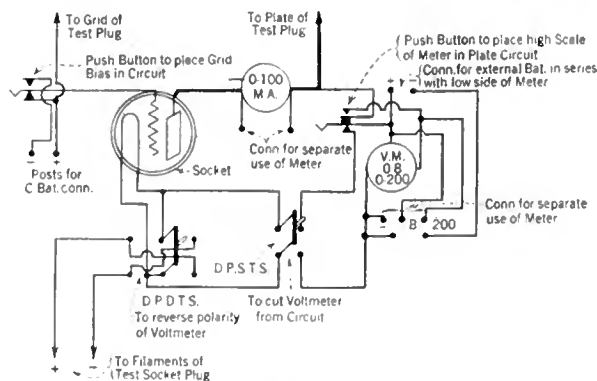

FIG. 1. DIAGRAM OF THE TEST SET

An interesting short circuit of a peculiar nature was discovered recently in a Radiola 18. The receiver provided entirely satisfactory results for several months before the trouble developed, and then the owner reported that the only way it was possible to obtain reception was to remove the first r.f. tube. The service man who was sent on the job went prepared to replace the tube which he considered defective. However, it was found that this was not the cause of the trouble. Upon removing the set from the cabinet after the usual test failed to indicate the fault, it was discovered that when the tube was inserted in the socket, instead of fitting into the contact springs, one of the filament prongs pushed its contact spring against another lead, thus causing a dead short circuit through the first r.f. coil and making the set inoperative. A simple operation with a pair of pliers shifted the spring to its proper position and corrected the difficulty.

One of the simplest receivers ever placed on the market developed one of the most unusual difficulties which has ever come to the attention of the writer. The set referred to was one of the old bread-board-type Atwater Kent receivers, and because of the simplicity of the receiver no complications were expected when the call for a service man was received. The owner stated that the set performed perfectly on the previous evening, but that he was now unable to coax it into operating. When the service man arrived he discovered that the set would play satisfactorily when held in the hand, but as soon as it was placed on the table it was inoperative; this was indeed an unusual condition. After carefully checking the set it was found in perfect condition, and then the surroundings were examined. Finally the trouble was found to be caused by the table cover on which the set had been placed; the cover being made of metallic tinsel, it caused a number of short circuits in the exposed wiring of the receiver. Then a little judicious questioning disclosed that the lady of the house had placed the table cover under the set during the day, and this explained why the set performed on the previous evening.

Table covers having metallic tinsel in their make-up have been the cause of more than one set being inoperative. A few days after the experience described above a service man was asked to repair a Radiola 18 which was found to have a short circuit caused in this way. In this particular case the location of the short circuit was never discovered, but removing the table cover corrected the difficulty.

CARELESSNESS IN SOLDERING

INNUMERABLE short circuits are caused by carelessness in soldering at the factory, and a recent example of this was found in a Radiola 30A. This set had been operating perfectly for a period of three months when it suddenly stopped, and all the usual tests failed to disclose the cause; even the continuity test of the manufacturer did not show anything wrong, still the set remained perfectly silent. Finally, it was discovered after a careful inspection, that a thread of solder, which was so fine that it was barely visible to the eye, was across the antenna and ground connections. This thread of solder probably was caused by the iron being slid from one connection to another when the set was wired and it did not cause a short circuit until the vibrations from the speaker caused it to sag. However, in the proper position, a thin piece of solder is as effective in stopping the operation of a receiver as a piece of No. 14 bus bar.



The Service Man's Corner



THE number of radio service men appears to be increasing with great rapidity.

Many service men, both old and new are readers of RADIO BROADCAST and quite naturally look to these pages for information of specific help to them in their daily problems. It is true, in a sense, that every radio article is of some help to those working in the field, but articles prepared with the problems of the service man chiefly in mind are badly needed.

Regular features now found in this magazine are designed to be of general help to those working in this field. In this classification fall the RADIO BROADCAST Laboratory Data Sheets, RADIO BROADCAST's Service Data Sheets on Manufactured Receivers, "Strays" from the Laboratory, "Our Readers Suggest . . ." and to a certain extent, RADIO BROADCAST's Home Study Sheets. And, beginning with the November issue, we started a series of general articles on radio service problems by B. B. Alcorn.

The chief problems encountered in the field by service men are classified in order of their importance by Mr. Alcorn as follows:

1. Dead tubes.
2. Run-down batteries.
3. Open circuits.
4. Defective parts.
5. Defective grounds.
6. Use of various "gadgets."
7. Defective antenna.
8. Misconnections.
9. Short circuits.
10. Lightning arresters.

A few of these problems were discussed in Mr. Alcorn's November article. In later articles, he treats of the others. Do men actually facing the problems of curing sick radio sets in the field agree with this estimate? If not, in what order do they list the troubles? What interesting shortcuts to the work in hand have they evolved? What simple test-sets have they built for their own use? What small and persistently annoying little problems have been solved in practise? Wouldn't a short description of any one of these pet ideas prove helpful to others doing the same sort of work? "The Service Man's Corner" will be a regular feature of RADIO BROADCAST from this issue on, and contributions from service men and professional set builders are welcomed and will be paid for at regular rates.

WHAT ONE SERVICE MAN SAYS

THE data that I feel is most needed by the service man is along the lines of test apparatus that he can construct himself, and so know the whys and wherefores of what is happening when he uses the test sets. I have found a number of service men who can use the more elaborate



test sets put out by several concerns. But few of them understand what the different readings show them about the condition of the receiver under test. These really fine pieces of apparatus are not

servicing their purpose unless they are in the hands of one who really knows how to use them." This service man concludes: "The servicing of radio receivers is a profession that no one need be ashamed of and the radio industry would certainly suffer if all service men were to be removed from the field."

The radio service man will not depart from the field, for he is too valuable a part of the present radio structure. "The Service Man's Corner" in RADIO BROADCAST will, we hope, be of help in making his work easier, by affording a medium where ideas and comment useful to him can be exchanged.

Field Suggestions

WHEN I received a letter from the editor of RADIO BROADCAST, suggesting that suggestions from service men would be appreciated and asking if I had anything to say, I felt much as I would if anybody had hinted that I might improve Bobby Jones' drive. And—in case you

WITH this issue, we start a regular page for the practising service man. This department will, we hope, be a forum where service men can discuss their problems, get their pet ideas into print, and see now and then a hint which will be useful in their daily work. Contributions, which preferably should be short, to the point and typewritten, are solicited and will be paid for if used. Address your articles to the editor, "The Service Man's Corner."

—THE EDITOR.

don't know—my golf drive looks like a sine wave. I have fooled around with radio receivers for some time, starting just after "ham" radio opened up after the war, so I can safely say I know nothing about radio. (You know, when you first start, you know it all). I've picked up a few kinks, most of which are doubtless ancient history to real service men. But I am glad to write about them in the hope that it will help bring to light some really good information on the subject from others. There seems to be a surprising dearth of information on the subject; I can't find any book that covers it.

Use of a Set-Analyzer: The service man should have in his kit a good set analyzer, of any good make. Working without one makes the job harder than necessary, and the use of one has a valuable psychological effect on the set owner, which is worth something. This unit should be capable of measurements on both battery- and a.c.-operated sets, and its use should be thoroughly studied.

Another tool almost as useful is a modulated oscillator that will cover the broadcast spectrum, which can be modulated for balancing sets using neutralized circuits. I have one that is small, self-contained, and does the job. Single-control sets are now in wide use, and if the condensers in the set under test do not gang or do not follow very closely, the receiver cannot give its best performance. One of these oscillators will permit the

service man to adjust the condensers to a nicety. Unless there is an adjustment provided, you do it by bending condenser plates, of course. The plates will get out of line in shipping, even when every care is taken at the factory. That, we are sorry to say, is not always the case. (A modulated oscillator was described on page 90, June, 1927, RADIO BROADCAST).

A tool I want is a tube checker working off the a.c. light socket to handle any of the usual tubes. They are on the market, but the price is too high for me and I am hoping RADIO BROADCAST will tell us how to build one. [A description of such a tube-checker as constructed in our Laboratory will appear in "The Service Man's Corner" in an early issue.—Editor.]

—H. J. GODDARD, Ellendale, N. D.

MISCELLANEOUS SERVICE SUGGESTIONS

MR. GODDARD has noted down some other service suggestions, which follow:

Line-voltage control: The advent of a.c. sets has shown up the floppy condition of the average commercial power line as nothing else could. Many a set is hooked to a line that varies from 105 to 125 volts. The latter condition is especially hard on tubes. Every service man should see to it, if the line voltage is high, that it is reduced to normal before it reaches the set. A 50-ohm resistor that will handle around 40 watts will do the trick. I like them variable particularly if they can be mounted on a bracket in a console, out of sight. They are cheap and will pay for themselves in no time. I'd like to see some reputable company build such a resistor that can be plugged-in between the outlet and the set plug so that a turn of the cap will permit adjustment. There should be a big sale for them. [A number of resistors which can be used for this purpose are now on the market. Although none of them have precisely the features which the writer desires, the adjustable units are satisfactory for the purpose.—Editor.]

Excessive plate voltage: Don't forget that a high plate voltage is almost as hard on a tube as high filament voltage. Watch that plate voltage if you want your tubes to last.

Blinking a.c. tubes: Every now and then you find an a.c. tube that is a blinker. These tubes start all right when cold, but when heated, a small break in the heater filament separates and for all practical purposes, the tube goes dead. When it cools a bit the ends come together and the tube starts again. I found a bad case of "fading" due to this very thing. Watching the tubes and noting which filament goes black of course localizes the trouble. [See p. 428 RADIO BROADCAST, April 1928, where this point was discussed at some length.—Editor.]

Caution: Ever notice the instructions to keep your hands out of a set when the a.c. is on? Manufacturers do that because they are sore at the mortician.

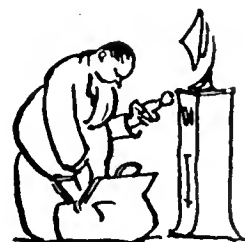

AS THE BROADCASTER SEES IT

BY CARL DREHER

Information in the Sound-Movie Field

IN ACCORDANCE with our recently announced intention to broaden the scope of this department, while not departing from its original purpose of serving the broadcaster, we are going to print considerable material on sound movies, of the same general type as the articles which have already appeared in "As the Broadcaster Sees It." For those readers who are interested professionally in talking pictures additional references will be of interest. I have prepared these in the form of a haphazard, informal bibliography—haphazard because sound movie articles giving varying degrees of technical information are appearing in great numbers and in widely scattered publications, so that any sort of complete collation is out of the question, and informal because it contains comments and information not usually included in the austere files of bibliographies. The list:

Transactions of the Society of Motion Picture Engineers, Vol. XII, No. 33. The current issue of this publication contains "A System of Motion Pictures with Sound," by H. B. Marvin of the General Electric Company; and "Some Remarks on the Acoustical Properties of Rooms," by J. B. Engl. Marvin's article is a description of the General Electric system as of April, 1928. With modifications and additions from other sources, this has become the R. C. A. Photophone system. The discussion is interesting, in that a good many questions are asked and answered which are likely to occur to almost all students of sound-movie technique. Copies of this issue may be secured from the Secretary of the Society, Mr. L. C. Porter, 5th and Sussex Sts., Harrison, N. J.,

at \$2.50 each. Earlier issues have also contained sound-movie material.

Motion Picture Projection, by James R. Cameron. Cameron Publishing Co., Inc., Manhattan Beach, N. Y. The fourth edition of this handbook contains over 1200 pages, of which 124, starting with page 699, are devoted to sound movies. There are descriptions, mostly of the "hand-out" variety, of Movietone, some of Hoxie's pre-Photophone equipment, Vitaphone, Vocafilm, and Phonofilm. The paper on the last named is ascribed to Dr. De Forest. Following these general outlines there are detailed instructions for the operation of Western Electric sound-picture apparatus. Apparently this stuff is reprinted from the manufacturer's bulletins. It includes general layout wiring diagrams. The whole book is \$6.00.

Bell System Technical Journal, Vol. V, No. 2, April, 1926. Published quarterly by the American Telephone and Telegraph Co., 195 Broadway, New York City. \$1.50 per year; 50 cents per copy. This issue contains a treatise on "The Alkali Metal Photo-electric Cell," by Dr. Herbert E. Ives. The general characteristics of central cathode and central anode cells are given, together with a consideration of the effect of such factors as gas, polarization and wavelength of the incident light, the nature of the emitting material and the surface coated with it, temperature, etc. A selected bibliography is included. For those who can follow scientific expositions articles of this and the following type are very valuable.

General Electric Review, Vol. 31, No. 7, July, 1928. Published monthly by the General Electric

Company at Schenectady, N. Y. \$3.00 per year; 30 cents per copy. This issue contains an article by Dr. L. R. Koller on "The Photo-Electric Cell." It is of the same scholarly type as Ives' paper and contains valuable curves. A few references are given as footnotes.

The American Cinematographer, Vol. IX, No. 6, September, 1928. A camera man's magazine published monthly by The American Society of Cinematographers, Inc., at the Guaranty Building, Hollywood, Calif. Yearly subscription is \$3.00; single copies, 25 cents. Material on sound pictures is printed quite regularly. The issue cited contains a story by Delmar A. Whitson on his system, and a discussion by the editor on "Who Invented Talkies?" The material is uneven and often not free from mistakes, but should prove informing to readers who do not know much about the field and want to acquire semi-technical knowledge.

The Motion Picture Projectionist, Vol. I, No. 11, September, 1928. This magazine is published monthly by the Craft Publishing Co., 45 West 45 Street, New York City; its readers are mostly motion-picture operators and the material is semi-technical, about on the same level as that in the *Cinematographer*. The September, 1928 issue contains a leading article on "Light Sensitive Cells" by Samuel Wein, a discussion by Friend Lescabour on "Just What May We Expect of Television?" some Electrical Research Products material, a reprint from the *Electrical Workers' Journal* by Prof. C. M. Jansky, "How a Rotary Brush of Light Paints Pictures from Afar" (picture transmission) and various little items of interest. Like most of the movie-trade journals, it carries a lot of audio picture stuff.

Exhibitors Herald and Moving Picture World. This trade weekly carries a monthly supplement, *Better Theatres*, which contains semi-technical sound-movie articles of varying degrees of reliability. The New York office is at 565 Fifth Avenue. Subscription costs \$3.00 a year. The September 1 issue carried a theatre architects' symposium, the conductor of which announced as one of the major conclusions, "Corrective work will be necessary in houses where no acoustical properties now exist," while some of the contributors were responsible for such illuminating statements as, "Will probably require the use of loud speaker equipment" (in answer to the question, "What effect will the synchronized pictures have on the acoustics in building the theatre of the future?") and, "Yes, where this has not been considered, sounds and tones are more sharp," the question being, "Will it be necessary for present day theatres to reconstruct so as to provide for the proper acoustical properties in the auditoriums?" Although the number of such inane answers was large, the idea of the symposium was good and a few searching comments were elicited. A conical piece in this issue was an illustration of a section of the dome of a theatre, showing treatment with acoustical felt, and captioned, "Acoustics in the Fox Theatre, Detroit." In the September 29 issue F. H. Richardson, who edits the "Better Projection" department of the *Exhibitors Herald and Moving Picture World* had a discursive but fairly informing article on "The Pick-Up," covering methods of getting audio

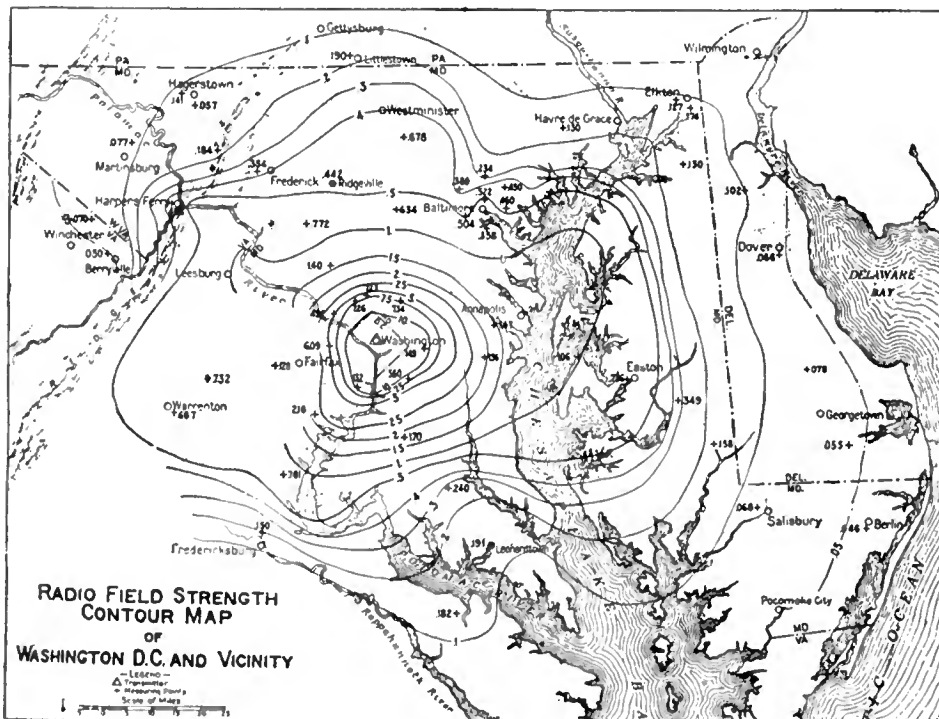

Illustration courtesy Institute of Radio Engineers

MAP OF WASHINGTON, D. C. SHOWING FIELD STRENGTH OF SIGNALS FROM WRC

input to the amplifiers from film and disc sound records. The illustrations were excellent. Richardson talks on paper, so to speak, which is fine in fostering informality but uses up a lot of words when carried too far. The August 25 issue of the same magazine carried a description of the RCA Photophone system, under the title of "How RCA Photophone Times Synchronism." Except for the title and a few mistakes in the text, the article was informing enough.

The combined bibliography and review printed above will give some idea of the variety of publications in which articles on or pertaining to sound pictures are to be found. It includes only those periodicals in which such material appears more or less regularly.

Broadcast Standardization

THE National Electrical Manufacturers' Association (NEMA) has a transmitter Section which deliberates occasionally on the subject of what broadcast transmitters should be like and in what terms it is valid to talk about them. The last meeting, in June, 1928, discussed a number of technical subjects especially pertinent in view of present developments.

The following methods for adherence to assigned frequencies by means of automatic master oscillator control are specified:

- a. Quartz crystal
- b. Standard clock with harmonic amplifier
- c. Tuning fork
- d. Magnetic striction bar

In any case it is specified that the master oscillator is to be arranged to be independent of external changes in humidity, temperature, barometric pressure, or loading.

Under the allied subject of frequency monitoring the Section adopted as a standard the use of an oscillating or heterodyne frequency meter whose frequency is held constant by one of the methods above, and so constructed that it can be shipped periodically to a primary standardizing laboratory.

In rating the coverage of a broadcasting station the population contained within the area over which the field strength is 5000 microvolts per meter, or more, is considered basic. Beyond this, under favorable transmission and reception conditions, it is permissible to add the population within a circular area having a radius four times the mean radius of the basic area. In determining the distances corresponding to the 5000 microvolts per meter field strength, measurements are to be made during the daytime on not less than 10 radii spaced at approximately equal angles around the station.

All this is, of course, empirical, but it is certainly effective in bringing down estimates of broadcast coverage from the blue sky to the solid earth. Applying the method to a specific case, we may use the Radio Field Strength Contour Map of Washington D. C., and Vicinity, presented as Fig. 9 in the paper by Bown and Gillett: "Distribution of Radio Waves from Broadcasting Stations over City Districts," (*Proceedings I. R. E.*, Vol. 12, No. 4, August, 1924). This map was based on measurements made on the old WCAP 500-watt transmitter, which is no longer in existence. The contour lines in the case of Washington are quite close to circles, the transmitting conditions being favorable for urban conditions (few high buildings, and a general distribution of low buildings and open spaces). The 5 millivolt per meter contour is a circle with a radius of about 14 miles around the transmitter. The population within this circle would have been the basic population

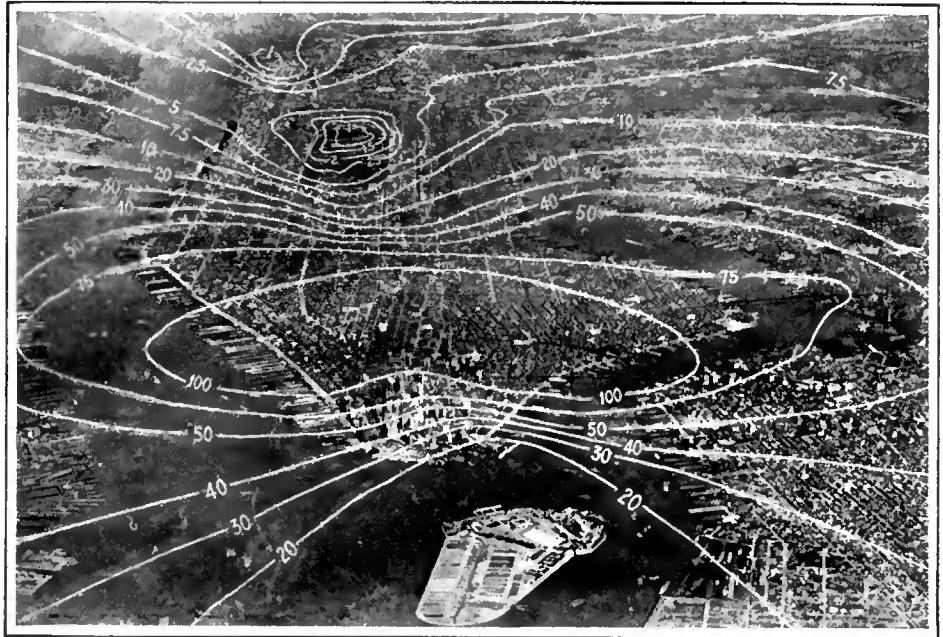

© Fairchild Aerial Camera Corp.

AN OLD MAP SHOWING RADIO FIELD-STRENGTH CONTOURS OF WCAP SUPERIMPOSED ON AN AERIAL PHOTOGRAPH OF NEW YORK CITY

served by WCAP. Under favorable conditions WCAP would have been credited with the population within a radius of 56 miles (four times the mean radius of the basic area, in this case fourteen miles). The half-tone on these pages shows the radio field strength contours for WCAP superimposed on an aerial photograph of New York City.

In rating the audio-frequency characteristics of a broadcasting station the NEMA Transmitter Section prescribed the following method: The number of octaves transmitted above 800 cycles (the mean speech frequency) and those transmitted below 800 cycles, with a deviation not to exceed plus or minus 1 TU, measured from the microphone input terminals to the rectified antenna output, shall be counted, and the smaller of these two numbers multiplied by two. The resulting number shall stand as the audio-frequency characteristic rating of the station.

On this basis a transmitter with a frequency characteristic flat within 1 TU between 100 and 7000 cycles would receive a rating of 6, since it transmits 3 octaves both above and below 800 cycles. If it only went up to 4000 cycles its rating would drop to 4, since it would be based on the two octaves above 800. Even if it went down as low as 50 cycles it would receive no extra credit, since the method of rating requires a balance between the ability to transmit high and low notes. About the highest rating within reach is 8, entailing flat transmission up to 12,800 cycles on the high end, and 50 cycles on the low. Apparently no one can get credit for going down below 50 cycles. If loud speakers are improved this point might be criticized, and likewise the 1 TU tolerance is open to question, since it cannot be detected by ear. A 3 TU tolerance might be preferable in practice. The general method, however, seems excellent.

Under "Modulation Capability" the committee specifies a single-frequency sine-wave audio input, to the maximum degree of modulation possible without "noticeable distortion," the analysis being on the basis of rectified radio-frequency output.

For the purpose of supervising modulation the Section specifies the use of a standard volume

indicator, on the scale of which the following relative limits are to be allowed:

Constant testing tone	30 divisions
Music peaks	30
Piano peaks	20
Speech	15-20

These values correspond to standard practice in chain broadcasting. The piano is more sensitive to slight overloading and so is given more margin, while speech is kept down to a value where announcements will not break into the music with obtrusive loudness.

Regarding microphone set-ups for broadcasting the committee decided that, in "view of the present relatively undeveloped state of this portion of the art," this subject should be tabled. This was no doubt a prudent move, since as things stand there are as many microphone set-ups for a given aggregation of musicians as there are musicians, announcers, engineers, musical directors, acousticians, program managers, commercial sponsors, studio supervisors, and advertising experts in the room, every man is sure he is right, and nobody can prove anything one way or the other.

Under "Standard Reference ('Zero') Level for Broadcasting Use," the NEMA group laid down the following specification: "It shall be standard for broadcasting use, to regard the term 'reference level' ('Zero level') as referring to a power of 10 milliwatts, corresponding to a current of 4.17 milliamperes flowing through a resistance of 600 ohms, or 2.47 volts across 600 ohms." This definition should put a stop to the endless wrangling about "zero level" which has been going on among the broadcasters.

Transmitter name plates, says the NEMA, should contain the following data: (a) Power rating in kilowatts; (b) Radio-frequency range over which the set will deliver full power; (c) Characteristics of the antenna for which the set is designed. That the power rating is to be in terms of power delivered to the antenna should have been specified, since in many countries power to the plates of the radio-frequency tubes is the basis of rating.

If the Transmitter Section continues its work on this plane it will become one of the most influential agencies in this branch of the industry.

Some Experiments With Band-Pass Filters

By KENDALL CLOUGH

Engineering Department, Silver-Marshall, Inc.

FOR months we have been trying to secure quantitative data on band-pass selectors and filters for use at broadcast frequencies. Not only does Mr. Clough, who is Chief Engineer of Silver Marshall, Inc., give the result of his laboratory work, but he gives some idea of how the home experimenter may play with the circuit for himself. Mr. Clough promises more interesting how-to-do-it material for an early issue.

—THE EDITOR.

A CONSIDERABLE amount of material has appeared in the engineering press on band-pass filters for radio-frequency tuners. Principal among these is the circuit discussed by Dr. Vreeland in the *Proceedings of the Institute of Radio Engineers*, March, 1928. In his paper Dr. Vreeland points out very completely the advantages of the use of a band-type filter in the tuner of the receiver, but for the benefit of those who have not had access to this paper, these advantages are redescribed here.

If we were to connect a stage of radio-frequency amplification, as shown in the circuit of Fig. 1, and run a resonance curve at 1000 kc., we would find that the circuit responded at and about resonance as shown in curve A of Fig. 2. Now in receiving a signal from a transmitter at 1000 kc., we would find that, in the course of modulation, frequencies varying from 995 kc. to 1005 kc., had been combined with the carrier. Obviously, if the reproduction is to be of the best, a band of frequencies must be transmitted from the antenna to the loud speaker with equal amplitudes rather than the single carrier wave only. Just how wide this frequency band should be has been the point of many discussions, some contending that we need to regard only a band 5 or 6 kc. either side of resonance, while others believe that a band 10 kc. wide each side of the carrier is necessary for perfect fidelity of reproduction. The finest audio equipment manufactured to-day is designed on the 5 kc. basis, so it seems superfluous to consider a band of greater width than this. We are not concerned here with the actual band width, however. The fact remains that, whichever stand one wishes to take, the resonance curve A of Fig. 2 does not permit the free passage of a band of frequencies of any

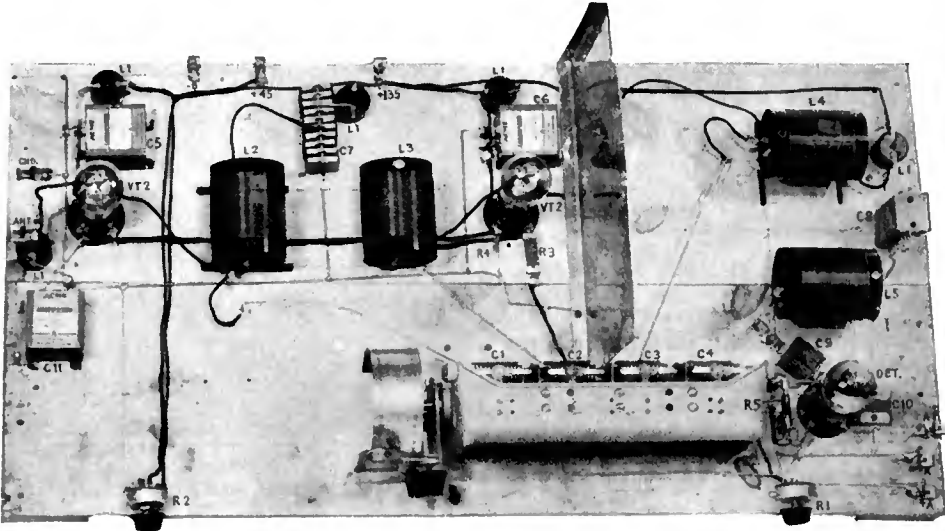

THIS PICTURE SHOWS THE EXPERIMENTAL BREADBOARD RECEIVER WHICH THE WRITER CONSTRUCTED TO TEST THE BAND-PASS PRINCIPLE

appreciable width. It will be seen in the curve that a frequency 5 kc. off resonance is amplified only 83 per cent. as greatly as the carrier, and a frequency 10 kc. off resonance only 62 per cent. as great.

RESULTS WITH THREE STAGES

FROM an interference standpoint the single stage of amplification would be far from adequate for modern conditions, so we have shown the resonance curve B in Fig. 2 which was obtained by cascading three of the circuits. It can be seen that the selectivity to an interfering station is greater, while the 5 kc. amplification is only 60 per cent. of normal and the 10 kc. amplification 25 per cent. of that of the carrier. The operation of this receiver would be equivalent to the use of a tuner with a perfect band pass and an audio amplifier having good amplification of the bass notes and falling to 60 per cent. of the bass amplification at 5000 cycles, and 25 per cent. at 10,000 cycles. It should be remarked that the receiver having the resonance curve B of Fig. 2 would not be considered a particularly selective receiver, so the reader can judge for himself the side-band cutting that is going on in the high-grade selective outfits. The ear is a tolerant device, and never seems to miss that which it has not heard.

Now, it may be demonstrated that the resonance curve shown is a definite geometrical shape. By this we mean that there is no adjustment (such as the resistance of the coil, the primary coupling, or the L/C ratio) which will cause the circuit to admit, say, a 5 kc. band with more facility without admitting an interfering station 10 or 20 kc. off resonance with corresponding facility. Thus, the only circuit of the usual resonant type which would provide perfect fidelity would be a circuit infinitely broad, a mathematical fiction which would be worthless in reality. This indicates that an entire change in the shape of tuner response would be desirable.

The dotted-line rectangular curve of Fig. 2 would be the theoretical ideal shape. This shape is not capable of attainment, but there is a cir-

cuit, old in the art, which under proper conditions will produce a response approximating this curve more or less closely.

Dr. Vreeland has discussed a similar circuit (Fig. 3) in detail in the paper mentioned, but it can be shown that this circuit is the analytical equivalent of the circuit with which we are to deal, Fig. 4, and which has been covered theoretically in all standard texts. So thoroughly has it been discussed that there is little we can add to the treatment other than to present curves and observations made in the laboratory. It is hoped that certain readers will find sufficient material and interest in these notes to enable them to go on with the experiments in this interesting field of band-pass filters which is far from a state of perfect practical application.

The theory of this circuit indicates that, when the coils, coil resistances, and condenser capacities are identical in each circuit, both circuits are tuned to the same frequency (due to the identical construction) when operated independently.

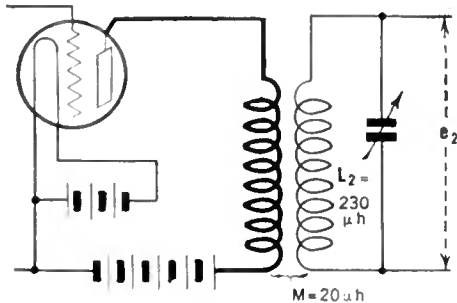

FIG. 1

A transformer with a tuned secondary constitutes the coupling device used between one radio-frequency amplifier tube and another in the vast majority of present-day receivers.

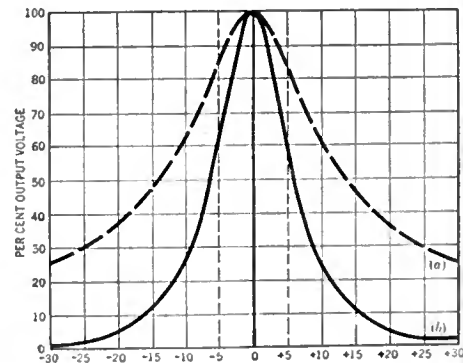

FIG. 2

If the voltage across the condenser in Fig. 1 (e_2) were measured as the frequency of the voltage input to the preceding tube was changed, a curve similar to "a" in this graph would result. If three stages were used, the selectivity would be greater, as shown by the decreased response at points far away from resonance in curve "b."

However, they actually tune to two separate frequencies when operated with coupling between the two circuits as shown. In other words, if the coils and capacities are of the proper size to tune both circuits, $L_1, C_1,$ and $L_2, C_2,$ to a frequency of F_1 kc. independently, the combination will not have any resonant peak at F_1 kc., but will have two resonant peaks at other frequencies. One of these peaks will be F_m kc. above the frequency of resonance, the other will be F_m below the frequency of resonance and this interval of F_m is defined by the equation:

$$\frac{M}{L_1} = \frac{M}{L_2} = 2 \frac{f_m}{f_1} \dots \dots \dots (1)$$

This equation says in simple terms that, if the mutual inductance between the coils is A per cent. of the inductance of either coil, there will be a peak of resonance $A/2$ per cent. either side of the frequency of resonance of the circuits considered independently. Thus, in the circuit of Fig. 4, if we select two coils of 230 microhenries each, tune them independently to 1000 kc., and then couple them with a mutual inductance of 2.3 microhenries, there will not be a resonant peak

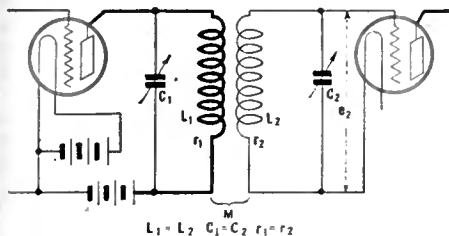

FIG. 4

Mr. Clough chose to study this variation of the Vreeland scheme—he uses the mutual inductance between two coils as the coupling impedance.

at 1000 kc., but there will be two other peaks, one at 995 kc., and the other at 1005 kc. Anticipating that this arrangement would approximate ideal selectivity, the circuit was set up for measurement and curves were run.

ANALYSIS OF CURVES

THE circuit used for these curves is shown in Fig. 5. Two commercial coils of very low-loss construction, the specifications of which are given on the circuit, were chosen for the tuner. Two mechanical placements are given in Fig. 5A which resulted in a measured mutual inductance of 1 per cent. of the coil inductance. In order to compensate the tube and other capacities of the circuit, the tuning of the condensers was accom-

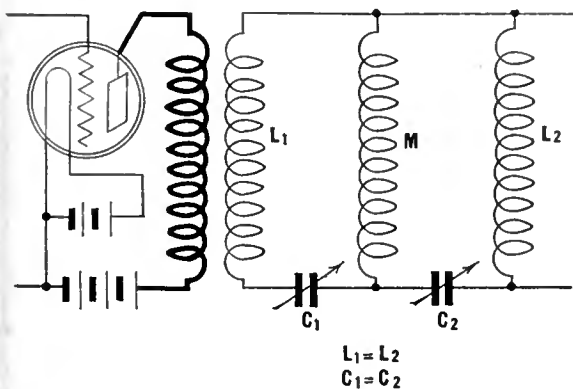

FIG. 3

Dr. Vreeland's circuit started all the discussion regarding band-pass tuning for broadcast-frequency amplifiers. It consists of two identical coils and condensers tuned to the same frequency and coupled together by an inductance.

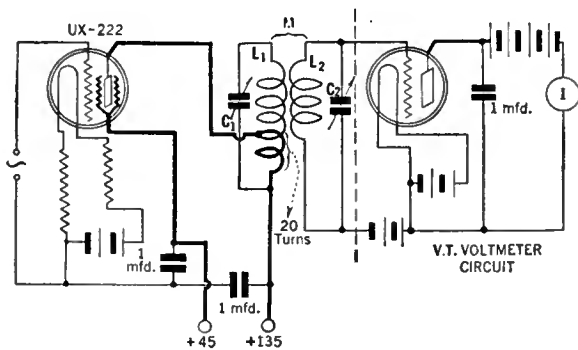

FIG. 5

How the circuit actually was set-up to be measured. A screen-grid tube fed the vacuum-tube voltmeter by means of the band-pass coupling mechanism. Diagram A—Two possible methods of obtaining one per cent. coupling between the two Silver Marshall coils used by Mr. Clough.

NEW FILTER UNIT

OTHER studies of this circuit indicate that the coil resistance must be kept very low in order to maintain the desired shape of curve and amplification for the stage. A similar type of band-pass filter having two sections has appeared recently upon the market and the writer had an opportunity of running a curve on the selector feature. The size of the coils was such that a high resistance could be predicted and the resulting curve is shown in Fig. 8. It will be noted that the amplitude varies very badly with the frequency and the band effect, while better than the average tuner, is far from the desired shape.

To check by actual observation the effect of the band passed on the reception, a receiver was made in breadboard style with two of the band circuits and screen-grid tubes. Feeling that some readers may desire to hear this circuit for them-

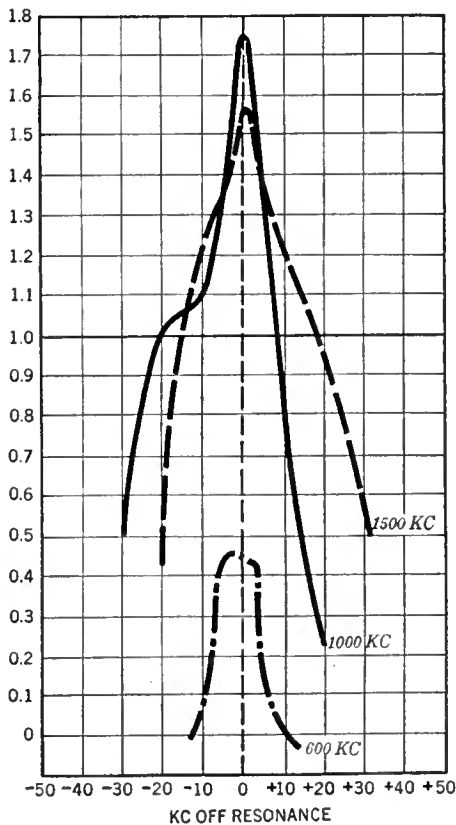

FIG. 8

A commercial receiver uses a system somewhat similar to the one described in this article. The result obtained in measuring the ratio between output and input voltages of such a band-pass selector is shown in this figure.

plished by disconnecting the primary condenser, $C_1,$ and tuning the secondary to resonance with the desired wave, then disconnecting the secondary condenser, $C_2,$ and tuning the primary. It was necessary to use a strong signal from the oscillator while tuning in this manner as the transfer from one coil to the other was very low. After tuning each circuit independently, both condensers were connected and the curve for a particular frequency measured. These curves were taken at 600, 1000, and 1500 kc., and are shown in the full lines of Fig. 6. It will be noted that they check very well with the theory of the circuit, for in the 600 kc. curve Fig. 6A, we have the two resonant humps lying very close to 3 kc. off resonance on either side while in the 1000 kc. curve, Fig. 6B, they are 5 kc. off the normal resonance of the individual circuits. The 1500 kc. curve did not turn out as well, although the separate resonances can still be distinguished. It will be noted that the curve at 1000 kc. compares very favorably with the ideal curve as the amplification varies very little in the 5 kc. pass band either side of the carrier. Attention is called to the variation with frequency in the width of the band passed in the three curves, which was predicted in equation (1) to which we will refer later.

The low amplification obtained with the screen-grid tube in the above curves is of no moment for our discussion. It was due to the low value of coupling used between the tube and primary circuit (20 turns at the base of the coil), which was employed in order to prevent the tube circuit from affecting the coil circuit until the curve shapes were assured.

In order to compare the shapes of the band curves of Fig. 6 with the performance that would be obtained when using the same tube, coupling, and coils in Fig. 7, the secondary circuit was removed and the measurement repeated with the single circuit shown in Fig. 7. These curves are plotted in dotted lines in Fig. 6 so they may be compared with the band-pass filter performance. It will be noted that at each measured frequency the selectivity of the band circuit is greater than the ordinary resonant circuit and that the amplification is about on a par, one with the other.

Other curves were checked using the whole primary coil for coupling to the tube. It was found that the curve shapes remained substantially the same as shown in the full lines of Fig. 6, but the amplification went up to an average of 30 per stage.

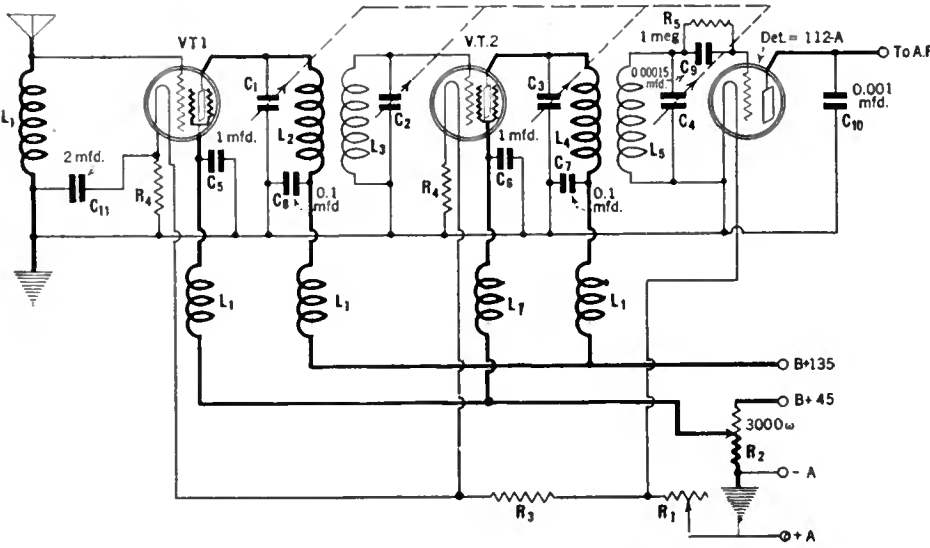

FIG. 9

The complete schematic diagram of the experimental breadboard receiver which is pictured at the head of this article. Note the thorough filtering of all the screen-grid and plate leads, the volume control which varies the screen-grid voltage, and the absence of shielding except the single metal plate.

selves, the complete circuit diagram of this setup is given in Fig. 9, as well as a photograph from which the physical considerations can be seen. One coil of each of the pairs was mounted in slots so that the coupling could be varied, thus varying the width of the pass band. The distance between coils used in making the curves was marked so that it could be referred to during operation of the receiver.

This receiver was operated for two evenings in conjunction with a Silver-Marshall type 682-250 pack with remarkable results from a quality standpoint. Several unbiased observers stated that it was the finest quality of reception they had ever heard, noting particularly the excellent timbre of the high notes of the piano and organ. It would be even safe to say that some of the curse is removed from soprano solos when the overtones are freely admitted by a band filter.

By placing a millimeter (0-3) in the plate circuit of the detector, the double hump of the curve could be noted at the lower broadcast frequencies. Selectivity was ample for Chicago conditions, good clear spaces being obtained between the local stations in a location where local field strengths were very great. In these clear spaces on the dial two out-of-town stations could be heard weakly, but the amplification of the system was not sufficient to provide a good signal. The receiver in the form indicated could be called an excellent local receiver of the highest quality. To extend the scope of this model beyond local reception, two possibilities present themselves for the future. The first would be the addition of hand-pass filter stages. This does not appear feasible except for those who can bear the expense and the necessary difficulties attendant with the matching of the large number of stages which would be involved. The other possibility is the use of a broad amplifier having no manual adjustments and equally responsive over the whole broadcast band. Many will recall the amplifiers of this type used in the early days of broadcasting when the tuned radio-frequency receiver came to the rescue. Perhaps with more general knowledge of electrical theory better success could be obtained with this type of circuit than

in the past. The two tuned circuits above present sufficient selectivity to form very fine receivers with a good "untuned" amplifier of this type.

CONCLUSIONS

WHILE this is not intended to be a "final hearing" on the subject of band-pass amplifiers, it would appear that sufficient man-

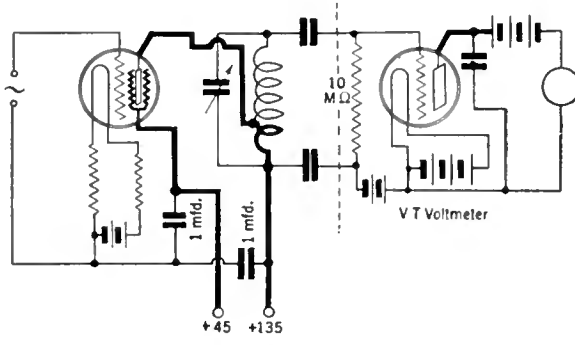

FIG. 7

The dotted curves in Fig. 6 were taken with this circuit, which is an auto-transformer in which part of the coil is used as primary and all of it as secondary.

material has been presented to arrive at the following conclusions with regard to circuits of the type discussed:

(1) That the coils must be carefully matched and of low-loss construction in order to obtain a

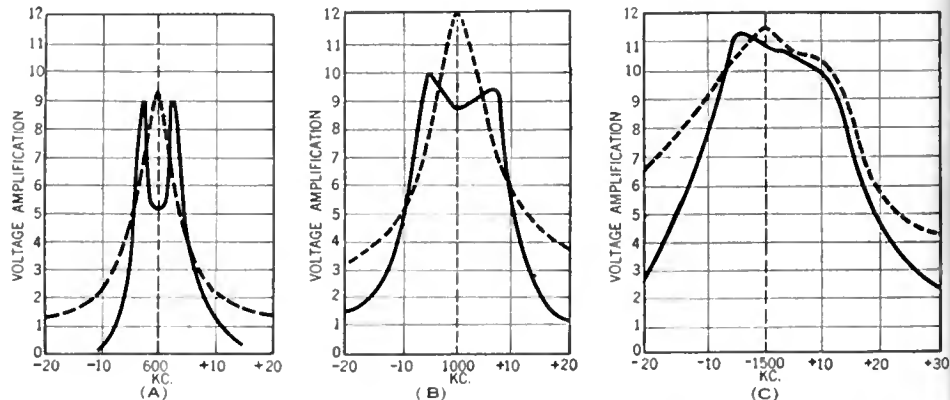

FIG. 6

The result—note that in each case the dotted curve, which represents a conventional transformer with only the secondary tuned, has poorer selectivity than the double-tuned transformer.

good band-pass filter effect. Good coils are usually large physically, so good band-pass filters can be expected to have a considerable amount of bulk in their finished form.

(2) That with good coils, better selectivity per stage can be attained than is to be had with the same coil operating as a conventional radio-frequency transformer. In general, it can be said that this increase will not be great enough to compensate the greater cost of the band-pass tuner stage, which is at least double that of the single circuit.

(3) That the width of the band passed will vary with frequency when attempting to tune the broadcast band by means of fixed coils and variable condensers. This follows from the theory of the device, and was confirmed by the curves which show that with a 1 per cent. coupling the band passed was 10 kc. wide (total) at 1000 kc.; 6 kc. wide at 600 kc. This constant percentage relationship prevents the attainment of the correct band width except over a small range of frequencies without changing the coupling between the coils. A similar situation has been long tolerated in radio-frequency transformers, however, so this is not a serious consideration.

(4) That it is not possible to cascade sufficient of these stages to obtain the degree of amplification that is usual in sensitive radio receivers without prohibitive cost and constructional difficulties.

(5) Far superior tone quality can be obtained by the use of a band-pass device than from the use of simple resonant circuits. It is undoubtedly on this last point that the band-pass filter will find a prominent place in the radio art.

LIST OF PARTS

THE apparatus used by the writer in making this investigation is given below. There is nothing special in any of the parts, and similar apparatus would perform as well. The coils, as mentioned above, must be of low-loss construction.

The list follows:

- L₁—1 S-M r.f. choke coil, No. 275;
- L₂, L₃, L₄, L₅—4 S-M inductances, No. 140 (minus primary);
- C₁, C₂, C₃, C₄—1 Four-gang condenser, 0.00035-mfd.;
- C₅, C₆, C₁₁—3 Parvult condensers, 2-mfd.;
- C₇, C₈—2 By-pass condensers, 0.1 mfd.;
- C₉—1 Carter condenser, 0.00015-mfd.;
- C₁₀—1 Condenser, 0.001-mfd.;
- R₁—1 Filament resistor, 10-ohm;
- R₂—1 Potentiometer, 3000-ohm;
- R₃—1 Filament ballast, 10-ohm;
- R₄—2 Filament ballasts, 10-ohm;
- R₅—1 Durham grid leak, 1-megohm;
- 8—Fahnestock clips;
- VT₁, VT₂—2 Screen-grid tubes;
- Det—1 Detector tube, 312-type.

Resonance in Radio Circuits

Part I

WHENEVER one tunes his radio receiver or transmitter he performs one of the most interesting and most fundamental experiments in all electrical science; he demonstrates a phenomenon that underlies practically all radio work. This is the phenomenon of resonance which occurs in an a.c. circuit under certain conditions of inductance, capacity, and frequency.

To study, experimentally, this phenomenon of resonance, we will need the following:

LIST OF APPARATUS

1. A simple radio-frequency generator consisting of a vacuum tube connected to a coil and condenser as in Fig. 1. The plate potential of 150-180 volts may be supplied by a standard B-power unit.

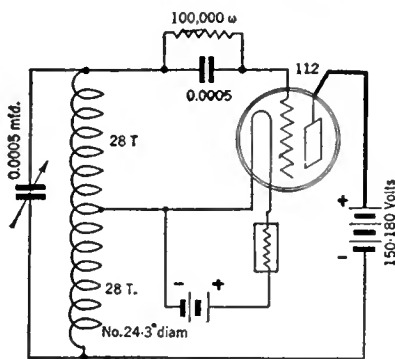

FIG. 1

2. A meter which will read radio-frequency current. The Weston Model 425 thermogalvanometer is a good example. It will measure 115 milliamperes at radio frequencies, has a resistance of 4.5 ohms, and costs \$18.50. This is rather expensive, but, in view of the number of uses to which it can be put, it is found in every well-equipped laboratory. Other meter manufacturers make similar meters.
3. A coil. The one used in taking data for this experiment was part of a Browning-Drake Kit and had the following dimensions: number of turns, 46; length of winding 1-11/16"; diameter, 2-11/16". The wire was about No. 24 and was spaced about the diameter of the wire.
4. A calibrated variable condenser—a good one is a General Radio Type 247-E in which the capacities are engraved on the dial.

PROCEDURE

Start up the generator, and if possible, measure its frequency or wave length. This is not essential, however. Connect the coil, the condenser, and the current meter in series. Couple the coil loosely to the generator inductance, and slowly tune either the generator or the tuning condenser until some current is read on the meter. Tune through "resonance," indicated when the current is a maximum, making sure that the meter does not go off scale. Now use as loose coupling as possible to the generator, and plot the current (or deflections of the meter) against condenser degrees and condenser capacities, as the tuning condenser is varied through resonance with the generator. A specimen "resonance" is shown in Fig. 2. Add a 10- to 30-ohm resistance in series with the circuit and repeat.

Calculate the inductance of the coil from the formula given in Home Study Sheet No 2 (August RADIO BROADCAST) and from the formula connecting wavelength, inductance and capacity,

$$(\text{wavelength})^2 = 3.54 \times L \times C$$

where
 C is in mmfd.
 L is in microhenries
 wavelength is in meters.

DISCUSSION

What is happening that the current in such a combination of apparatus, known as a series-resonant circuit, increases at first slowly, then more rapidly, then decreases sharply, and finally falls off to a very low figure?

The answer may be found in Home Study Sheets 7, 8 and 10. In these sheets the effect of a capacity, and an inductance upon the a.c. current in a circuit was discussed. Thus, in an inductive circuit

$$I = \frac{E}{X_L} = \frac{E}{6.28 \times L \times f}$$

and in a capacitive circuit,

$$I = \frac{E}{X_C} = E \times 6.28 \times C \times f$$

and when L, C, and R all exist in a series circuit, the current I is

$$I = \frac{E}{Z} = \frac{E}{\sqrt{R^2 + (X_L - X_C)^2}} = \frac{E}{\sqrt{R^2 + \left(L\omega - \frac{1}{C\omega}\right)^2}}$$

where Z is called the impedance of the circuit
 ω is equal to $6.28 \times f$
 f is the frequency in cycles
 X is the reactance of L or C

Now an inspection of this formula for current shows that the capacity reactance is to be subtracted from the inductive reactance to get the total reactance in the circuit which, combined with the resistance, forms the impedance which controls the flow of current. If, therefore, we add sufficient capacity reactance to the circuit, so that it is equal to the inductive reactance, the two, when combined by subtracting their values, add up to zero, and the impedance then is composed of the resistance only. In other words, tuning the condenser changes the capacity reactance, thereby decreasing the total reactance, decreasing the impedance, and increasing the current.

This is exactly what was done in the above experiment. We balanced out the inductive reactance, which is determined by the coil and the frequency, by changing the capacity reactance, which is determined by the condenser and the frequency. When the two reactances are equal in value but of opposite effect, the total impedance offered to the flow of current is very low, consisting of R only at this value of L, C, f, and the current is a maximum.

In a series resonant circuit the current may become very high although the driving voltage, which is across the entire circuit, may be fairly small, and although the individual reactances of the coil and condenser are large.

VOLTAGE IN CIRCUIT

As in all circuits the voltage across any part is the product of the current through it and its impedance. Thus the voltages across a resistance, inductance, or condenser in such a circuit are:

$$E_R = I \times R$$

$$E_L = I \times X_L = IL\omega$$

$$E_C = I \times X_C = \frac{I}{\omega C}$$

and since the current at resonance may become very high—it is governed by the voltage and resistance only—the voltage across the coil and condenser may become very high. For example, if 100 milliamperes flow in a circuit at a resonant frequency of 1000 kc. when the inductance is 200 microhenries, the voltage across the coil is

$$E_L = I \times L\omega = (100 \times 10^{-3}) \times (200 \times 10^{-6}) \times (6.28 \times 1000 \times 10^3) = 125.6 \text{ volts}$$

although, if the resistance in the circuit is 10 ohms, the impressed voltage necessary to drive 100 milliamperes through it is only one volt.

A series circuit may be tuned to resonance by varying either the capacity as is usually done—or the inductance, or the frequency. Below the resonant frequency the principal reactance is capacitive. The inductance offers little reactance at low frequencies. At frequencies higher than resonance, the major reactance is the inductance, because the condenser reactance steadily decreases with frequency. At the resonant frequency the two reactances are equal, and hence the voltages across them are equal. This occurs when $X_L = X_C$, or when

$$f = \frac{159200}{\sqrt{L \times C}} \text{ when } L = \mu\text{h, } C = \text{mmfd. } f = \text{kc.}$$

Thus a series-resonant circuit is a kind of voltage multiplier. A small driving voltage across a low-resistance ("Low-loss") circuit will cause a high current flow at resonance and a large voltage to appear across the inductance and coil.

PROBLEMS

1. Assume $L = 200$ microhenries, $C = 500$ mmfd, $R = 10$ ohms. Calculate the reactances, impedance, current, resistive, and inductive and capacitive voltages in the circuit when $E = 10$ volts. Plot all these against frequency from 400 to 600 kc. If the experiment outlined under Procedure has been carried out, use the values of L and C obtained there and assume $R = 10$ ohms. If the current is known, calculate the voltage across the circuit at resonance.
2. How do the two calculated inductance values check?
3. Does the current lag or lead the voltage below the resonant frequency? At the resonant frequency what happens to the phase angle? What above the resonant frequency?
4. In an amateur transmitter tuned to 40 meters, the antenna current is one ampere. This flows through a series tuning condenser of 100 mmfd. capacity at resonance. What voltage must the condenser stand?
5. In Problem 1, what is the ratio between the current at resonance and at 20 kc. below resonance? What would be this ratio if R were doubled, or halved? Do you see the importance of low-resistance circuits?

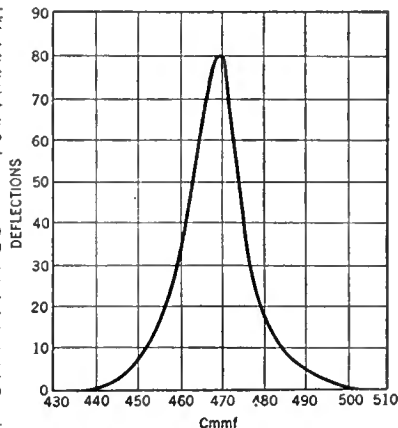

FIG. 2

Resonance in Radio Circuits

Part II

RESONANCE may occur in a radio circuit in one of two ways. The series resonant circuit was discussed in Home Study Sheet No. 11. Suppose, instead of having the voltage impressed in series with the inductance and capacity, it is impressed across the condenser and inductance connected in parallel, as in Fig. 1. What happens, as the frequency is changed?

DISCUSSION

Unfortunately the experiment to show just what happens to the various currents and voltages in such a circuit is difficult to perform. It is simple, however, to calculate what happens and to plot it. Instead of going into the laboratory for this experiment, then, we shall rely on the slide rule and graph paper to delve into another interesting radio phenomenon known as parallel resonance.

In a series circuit the same current flows through all the units, but the voltages across these units may differ. In a parallel circuit, the same voltage exists across the branches, but the currents through them differ. The total current, I , flowing out of the generator, in Fig. 1, is the sum of the currents flowing in the two branches. Since, however, a capacity reactance is considered as a negative reactance, the current through such a reactance may be considered as having an algebraic sign opposite to that of a current through an inductive branch. The total current, then, is the difference of the currents, i. e.,

$$I = I_L - I_C$$

and from previous Home Study Sheets, the currents in these branches may be calculated if the reactance and the voltage is known.

The formula above, which gives the generator current flowing into the parallel circuit, shows that if the current in the capacity equals the current in the inductance, the difference, or generator current, becomes zero.

IMPEDANCE OF PARALLEL CIRCUIT

The impedance of any device or circuit may be defined as the ratio between the voltage across it and the current through it. Thus, the impedance of a parallel tuned circuit is

$$Z = \frac{E}{I}$$

and if, at resonance, the current, I , is zero, the impedance must be infinitely high, because current would not flow out of the generator no matter how high its voltage.

A series-resonant circuit, looked at from the viewpoint of the generator is a very low-impedance circuit at resonance. The current it draws from the generator is large. On the other hand, at resonance the impedance of a parallel-resonant circuit, looked at from the generator, is very high, and the current fed into it from the generator is very small. Series circuits are used when low impedances are desired; parallel circuits, when high impedance circuits are needed.

If we measure, or calculate, the current flowing in each of the two branches in Fig. 1, and the total or generator current as well, we shall obtain curves similar to those in the accompanying figures. These are the theoretical curves and do not take the resistance of a circuit into account. Resistance usually exists in the inductance of such a circuit, but in well-designed radio circuits it is small compared with the inductive reactance of the coil. If this is true, the impedance into which the generator feeds current at resonance is equal numerically to $L^2\omega^2$ where R is the resistance of the coil.

As the frequency of the generator is changed, the current through the inductance decreases and the current through the capacity increases as in Fig. 2. At very low frequencies there is a large difference between the two currents—the inductance current being the larger—and so a large current flows from the generator. At very high frequencies the capacity current is much greater than the inductance current and so a large difference current, i. e., the generator current, flows as in Fig. 3. For this reason, below the resonant frequency the generator views the circuit as inductance shunted by a condenser whose reactance is so high it takes but little current. At frequencies above resonance the inductance has little effect upon the generator current and so the circuit is said to be capacitive. At the frequency which makes the inductive and capacitive

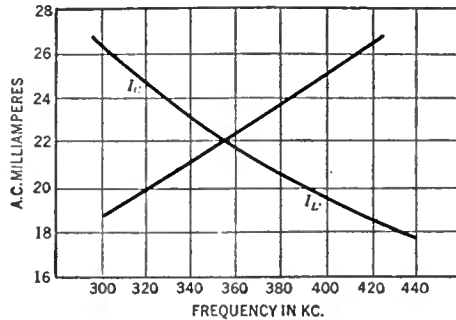

FIG. 2

reactances equal, the currents are equal, the circuit as a whole is neither capacitive or inductive and, therefore, must be resistive only, so far as the generator is concerned. At this frequency, then, the circuit looks like a resistance to the generator, and the expression above for its impedance is properly called its effective resistance. Thus,

$$R_{EFF} = \frac{L^2\omega^2}{R} \text{ or } \frac{L}{CR}$$

where L = coil inductance
 ω = $6.28 \times f$
 C = capacity required to resonate the coil
 R = series resistance of coil
 For example if $L = 200$ microhenries, $R = 10$ ohms and $f = 1000$ kc., $R_{EFF} = 160,000$ ohms.

PROCEDURE

1. Assume $L = 200$ microhenries, $C = 500$ mfd., $E = 10$ volts. As the frequency varies from 400 to 600 kc., calculate; a. reactance of inductive and capacitive branches, b. currents in these branches, c. total current flowing from generator, d. impedance presented to generator;

2. Plot all of this data against frequency.

PROBLEMS

1. If the coil in Procedure has 15 ohms resistance at 300 meters, and the grid and filament of a vacuum-tube amplifier is connected across the circuit, what impedance does the tube work out of? Suppose it is in the plate circuit of a power tube which feeds 100 milliamperes into it. What is the power required from the tube if $P = I^2 R_{EFF}$

2. An antenna-ground system has a capacity of 0.00025 mfd. An inductance is to be put in series with it so that the entire circuit will be resonant to 400 meters. Calculate the total circuit inductance. If a distant station impresses across this system causes voltage of 100 microvolts, what voltage is across the inductance at resonance?

3. An interfering station working on 600 meters also sets up across the antenna a voltage of 100 microvolts. If the system is tuned to 400 meters, what voltage at the interfering frequency will appear across the inductance?

4. Suppose in series with the antenna is connected a circuit like that of Fig. 1 and tuned to 600 meters. Assume the resistance of the coil is 10 ohms. Calculate the impedance this circuit would offer to the 400-meter and the 600-meter signals. Then calculate roughly the ratio of wanted to unwanted voltage across the inductance L . The complete antenna system is shown in Fig. 4. In calculating the impedance neglect the effect of L and C .

5. If doubling the inductance of a coil doubles its resistance, too, what effect upon the effective resistance of a shunt tuned circuit has doubling the inductance? Of course, a smaller condenser would be used to reach the resonant condition, how much smaller would the condenser be?

6. A plate-supply device has considerable 120-cycle hum in its output. Suppose a parallel tuned "trap" is placed in the positive lead. A 30-henry inductance is available. Calculate the size of condenser needed. If the inductance has 500 ohms resistance what impedance will the trap offer the 120-cycle current?

7. The maximum voltage gain that may be secured from a screen-grid tube may be calculated from $G_m \times R_{EFF}$, where G_m is the mutual conductance of the tube and R_{EFF} is the impedance of the tuned circuit into which the tube works. Assume that $G_m = 300$ micromhos, $L = 200$ microhenries, wavelength = 300 meters and calculate the maximum resistance that can be tolerated in the coil and condenser which tunes it to permit an amplification of 60. If the resistance of the coil is doubled, what happens to the gain of the tube and coil-condenser combination?

Note: Readers may send their answers to these questions to the Editor to be checked.

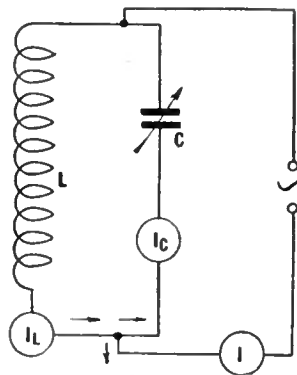

FIG. 1

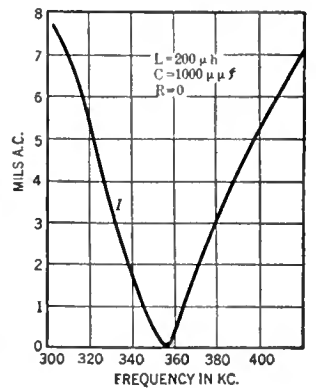

FIG. 3

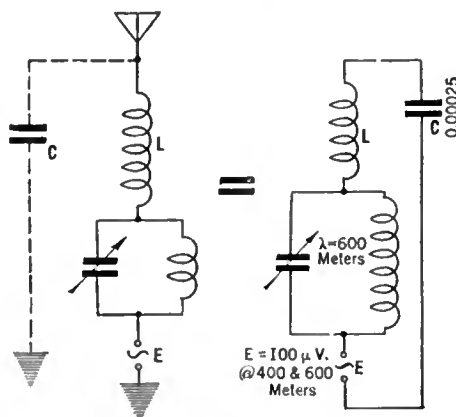

FIG. 4

LOUD SPEAKERS—A DEBATE

*Dynamic
Type*

Versus

*Magnetic
Type*



AT THE end of an average day, the waste-paper baskets in the Editorial Office of RADIO BROADCAST are almost filled with press releases written about every known kind of a radio equipment. It is a rare release which contains information which can be used in this magazine. The truth is, that it is a rare release which has any information of use to anyone. Occasionally, however, the mail clerk brings one which promises a great deal.

The following statements are taken from a release dated August 29th, titled "Little-known Facts About Well-known Cone Speakers," and signed by the Director of Research of a cone-type loud speaker corporation. The replies to these statements were made at our request by an engineer who has no connection with the loud-speaker industry, but who, in our opinion, is equipped with as much unbiased data as any engineer in the country. His interest, as shown in his statements below, is the interest, of engineering truth. We believe this little debate may give our readers more information than a much longer article written in conventional style and form.

The release: "It is freely claimed that the efficiency of the usual rocker-type driving unit for cone speakers is from 4 to 7 per cent., and that its power rating is strictly limited to that for which it is set. The Western Electric unit, for example, is set for 1 watt, the BBL for 2.5 watts, while the Stevens unit will take 3 watts and still maintain an efficiency of 7 per cent., although at 0.5 watt its efficiency is only 2 per cent."

Our engineer replies: "The so-called wattage that can be put into a speaker varies with the frequency. The Western Electric cone handles about $1\frac{1}{2}$ watts at the lower end of its response without striking the pole pieces. Because of its rather greater efficiency than most cones this gives as much sound output as a cone 3 TU less efficient capable of handling 3 watts."

We should like to put in a word here. The average listener need not worry about the power-handling ability of his loud speaker. What difference would it make if his speaker could handle 100 watts of energy without smoking, blasting, or hitting the pole pieces? What he should be interested in is the amount of sound he gets out of the speaker with a given elec-

trical input. We have stated already that, if a speaker could be made 10 TU more efficient than the best of our present devices, we could obtain sufficient volume of sound from it without using expensive power apparatus.

The fact that the efficiency of the unit which the release mentions differs at various power levels indicates, according to the engineer, "con-

stant 30 per cent., when actuated by push-pull amplifiers. When, however, they are actuated by ordinary transformers, and from a single power tube, the efficiency drops to as low as 20 per cent. with some distortion. In some of the cheaper makes, the efficiency is further impaired by mechanical losses due to the cone suspension."

Our engineer says: "The push-pull element has nothing to do with it. Equal efficiencies can be obtained with either single or push-pull amplifiers and transformers. An efficiency of 30 per cent., is probably high for even the best of the dynamic speakers. Any speaker worked from improper conditions will perform unfavorably."

The release: "These figures, let it be understood, are electrical only, and to obtain the overall efficiency, we must subtract the cone losses. It is quite true that in cones of the same size—the 18-inch size, for instance—the efficiency of a cone actuated by a dynamic unit is greater than that of one actuated by an electromagnetic unit. This is due to the greater power available for flexing the material, provided, of course, that the source is capable of furnishing the energy. On the other hand, it is well known that the amplitude of the apex of the cone varies inversely as the square of its diameter, plus a logarithmic constant for air slippage."

POWER VS. EFFICIENCY

THE engineer: "The power available has nothing to do with efficiency; the losses are what reduce it. Dynamic speakers may be made to have less eddy current and hysteresis losses than the rocking-armature units. In the latter type the armature itself is saturated rather heavily. In addition, mechanical masses are supported better and distributed so that impedances, both mechanical and the resultant electrical, are more uniform and permit of better matching in the dynamic type.

"This is true for a constant radiating power at a particular frequency, and provided the whole moves as a unit (piston) without interference between the front and back faces. This latter is not the case for the Western Electric type of cone, and is true for the dynamic only when the baffleboard is sufficiently large (diameter), massive and damped."

The release: "In practice this works out so that if an 18-inch cone requires 0.008-inch amplitude down to 100 cycles,

RADIO folk feel keenly that, out of the mass of near-accurate statements and downright mis-statements about topics which may at the moment be uppermost, there must be some generally accepted facts to which they may cling. This is usually so, but the search for simple and real truth is not easy. In the comparative merits of different types of loud speakers, the flow of inaccuracies has recently been especially strong. The short discussion here of the comparative merits of the magnetic vs. the moving-coil loud speaker is as technically accurate as we know how to make it, without ascending to the rarefied atmosphere of higher physics. We hope it proves interesting and valuable to our readers.

—THE EDITOR.

siderable lack of linearity in response. When the ratio of input to output is not linear, the harmonics are very bad."

EFFICIENCY OF DYNAMIC UNITS

SPEAKING of moving-coil loud speakers, the release states, "The very best design available develops an electrical efficiency of only 50 per cent., and this figure is attained only by employing a push-pull transformer which has been designed specially and constructed of very expensive material.

"The electrical efficiency of some of the most popular makes of electrodynamic speakers is a

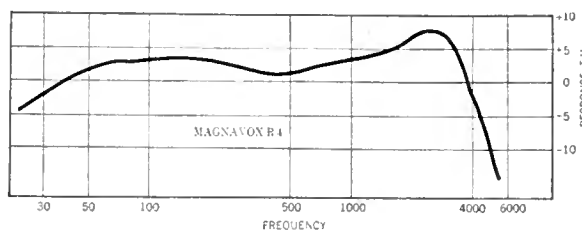

FIG. 1. FREQUENCY RESPONSE CURVE OF A TYPICAL MOVING-COIL SPEAKER

then a 7-inch cone will require 0.062 inch down to the same frequency. If, however, a dynamic speaker could reach only 100 cycles, it would not be satisfactory; and to reach 48 cycles, a stroke of plus or minus $\frac{1}{4}$ inch or $\frac{1}{2}$ inch is necessary. It is, of course, theoretically possible to make a dynamic unit with this stroke, but at the present time there are only two commercial speakers of this character, and both are sold complete with amplifier and power plant. The very best dynamic unit for 7-inch cones has a possible stroke of plus or minus $\frac{3}{8}$ inch. Others have a possible stroke of $\frac{1}{8}$ inch. One type examined in our laboratory had as little as a $\frac{3}{32}$ -inch stroke."

The engineer: "This depends upon how much energy must be radiated. Under any reasonable conditions it will be superior to the Western Electric type of cone in radiation (area x amplitude) at frequencies below 300 cycles because of the baffleboard's effect."

ELECTRICAL TROUBLES

THE release: "Electrical troubles are caused by the following factors: To begin with, dynamic units are not provided with a spring resilience as are the electromagnetic units. Push-pull actuation is therefore more essential. Again, in all cases an output transformer of special design is required, and unless made of special alloy cores, which are quite costly, it can introduce quite as much distortion as a third stage of audio amplification."

The engineer, replying on the spring resilience of the cone-type speaker: "That is the reason dynamic units are so very much superior to balanced-armature speakers from the standpoint of harmonics generated. Since they are always actuated by a.c., theoretically no restoring force should be necessary. The current itself will always return the moving system to the starting position. Push-pull actuation is obtained by the a.c., not by any push-pull feature of the amplifier system. The currents fed to a speaker by a push-pull amplifier can in no possible manner be told from those fed by a single-tube amplifier as long as neither is overloaded and the d.c. component is eliminated by a transformer or blocking condenser."

The release: "Many makes of dynamic speakers now on the market are provided with cheap transformers, so that the distortion caused by combinations of capacities, chokes and resistances—including cut-off filters intended to cover up poor design—tends to cut down the efficiency."

The engineer: "This is equally true of other types."

The release: "The greatest electrical loss, how-

ever, occurs in the movable coil itself. The impedance of the movable coil is not matched with the secondary of the output transformer; and even when it is nearly matched, the I²R loss of the coil is enormous. The reader can obtain a really practical picture of this loss if he stops to consider that in a correctly designed step-down transformer whose ratio is 50 to 1, the secondary wire is No. 18 while the dynamic coil is wound with No. 30 or 32! This means that the dynamic coil is being overloaded from 300 to 400 per cent."

The engineer: "The losses (I²R) in the coil are fairly large compared to those in certain other parts in the system, and account largely for the 30 to 50 per cent. efficiencies instead of 100 per cent. It is still better than the 3 to 7 per cent. efficiency obtained by other types. The moving coil cannot be considered as "overloaded" unless it is mechanically or electrically likely to be destroyed."

FIELD COIL EFFICIENCY

THE release: "The electrical efficiencies discussed above are those of the signal system only. In addition, we must consider the efficiency of the field, which is from 10 to 25 per cent. When a field for the signal of a 112-type tube was required, this was quite immaterial. To obtain a field for the signal from the 210- or 250-type tubes in push-pull, however, requires enormous power."

"Dynamics of the kind having a signal efficiency of about 20 per cent., with the field rated at 1 ampere at 6 volts were found to take 6 watts at 6 volts, while those having a signal efficiency of 30 per cent., required 16 watts. Those with a signal efficiency of 50 per cent. demanded a 50-watt field. The latter field requirements are far above the usual output of eliminators. Hence the field cannot be used as the eliminator filter choke, but must be fed with a separate rectifier."

The engineer: "Proper design of the magnetic circuit can reduce greatly this loss and apparent inefficiency."

In this connection, we understand the Vitaphone loud speakers in factory production have an average efficiency of 35 per cent., and that the field of these speakers consumes about 10 watts.

The release: "In conclusion, it should be noted that the deep bass notes developed by many dynamics are additive resonance, and if one likes this effect one can readily obtain it by much cheaper and simpler means. The deep resonance is caused by the fact that most dynamic cones are fastened to a metal frame which, in turn, is bolted to a large wooden baffle acting in the capacity of a diaphragm. This serves to accentuate certain low frequencies. To prove this, let the reader actuate a dynamic unit thus mounted, with an organ record of low pitch, and he will hear clearly a bass drum accompaniment. If this effect is desired, the same results can be produced with an impregnated cloth cone (of curved angle) glued to the same kind of baffle and actuated by a high-power electromagnetic unit."

The engineer, "No loud speaker is quite so free from the effects of resonance as the dynamic with a piston-type paper cone or properly designed moving system and horn. The reproduction of low notes is not due to resonance. The wooden baffle does not act as a diaphragm. In fact, the less it moves the more effective it becomes."

OUR DECISION

WE HAVE enjoyed this little argument. The cone designer is correct in stating that good cone-type speakers can deliver excellent quality; the engineer, whose feeling in favor of "dynamic" speakers is so evident, is correct

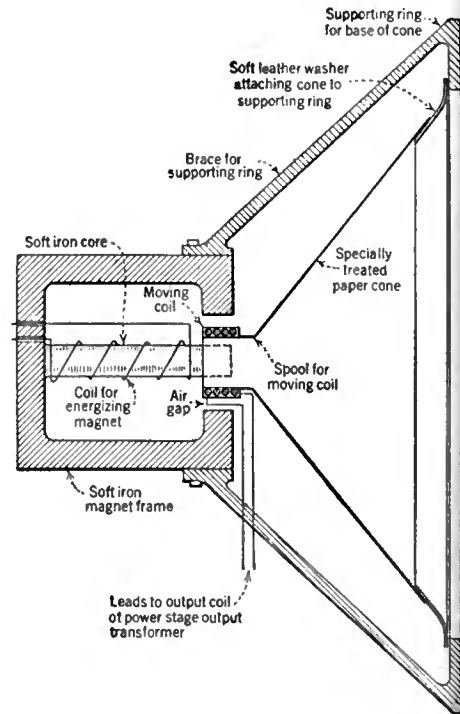

FIG. 3. CONSTRUCTION DETAIL OF A MOVING-COIL SPEAKER UNIT

too—for the best possible reproduction, a good moving-coil speaker is superior to a speaker of the Western Electric type.

There is only one more statement we hope everyone will understand—all speakers are dynamic speakers in that some of their parts move. All dynamic speakers, however, are not "moving-coil loud speakers" which are the type the engineer favors, and what nearly everyone thinks of when the word dynamic is mentioned. Up to the present time there is no type of speaker generally available which is the equal of the better grades of moving-coil loud speakers.

More Data on Loud Speakers

THE above argument will be followed by additional data on dynamic speakers, as the Editors have made arrangements with Joseph Morgan, of the International Resistance Company, for the preparation of another of his articles on loud speakers—the first appeared in August RADIO BROADCAST and was called "All About Loud Speakers." The second of Mr. Morgan's articles will be "All About Dynamic Loud Speakers," and he has been instructed to take every type of dynamic speaker now easily obtainable and put them through their paces in his laboratory. His article will contain curves showing how the various speakers respond to the necessary audio frequencies, what field currents they require, how much audio power is necessary, what their advantages and disadvantages are, and where the magnetic type of speaker stands in the path of progress toward better and better radio reception.

The advantage the second of Mr. Morgan's articles will have over other dynamic-speaker descriptions is that his remarks will be based upon laboratory measurements and actual tests, not upon matters of opinion. Together with the present article made up of the remarks of two engineers, it ought to equip any serious radio thinker with sufficient data to decide for himself and advise his friends on the question, "Is it worth while to invest in a dynamic speaker?"

—THE EDITOR.

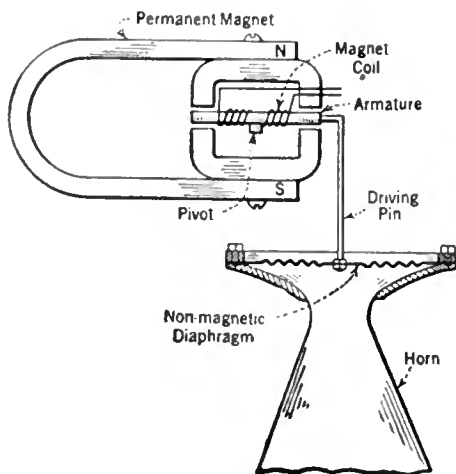
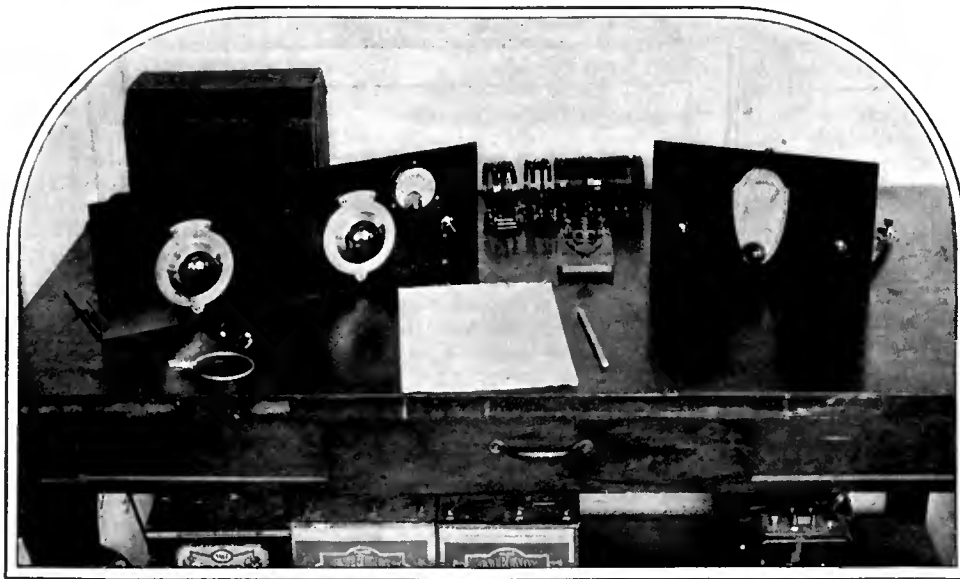

FIG. 2. CONSTRUCTION DETAIL OF A BALANCED-ARMATURE MAGNETIC UNIT



A TYPICAL WELL-ARRANGED AMATEUR STATION

Removing Nonsense from Short-Wave Transmission

By ROBERT S. KRUSE

THE transmitter described in the last two installments of this series will supply its owner with a considerable amount of pleasure, whether he be experimenter, scientist, engineer, tinker, or friendly "rag-chewer." It is not intended especially for the highly specialized message-handler, but is quite adapted to the uses of that group as well.

Just how it may be made to serve these various purposes may be told best after we have pushed aside certain very widespread hoaxes. That it is really necessary to do this can be made plain by recalling that grotesque hearing at Washington wherein a large group of gentlemen demanded all the short waves—and more—from the Federal Radio Commission. Not only did these representatives have in mind purposes that ranged from worthy to silly, but a goodly proportion of them were filled with the most amazing illusions as to the possibilities of short waves. Surely Mr. Average Citizen is at least as badly off. In order to give him a fair start one must surely equip him with something approaching the truth.

The fault lies with the evergreen enthusiasm of the reporter and the fish stories told him by the station owner. Between them they produce an illustrated story about some amateur station which is claimed to "talk to every country in the world and be in touch with Australia every night." (The quotation is genuine.) Probably neither one recognized this as a plain ordinary lie—yet a lie it is. No amateur (or professional) station can "talk to every country in the world" for the good reason that not all countries have stations which can reply. Again, one is perfectly safe in saying that no amateur station in this country has ever maintained daily contact with Australia (or any other foreign country with the exception of Canada or Mexico) for even one year. Any attempt to claim that a shorter demonstration is a proof can be set down as an admission

that the speaker is not familiar with the seasonal and climatic vagaries of short waves. There are many cases on record to show that quite good international amateur contacts may exist for several months, only to disappear completely with no assurance of recurrence twelve months later.

International amateur contacts are a post-graduate activity in any case. The beginner may make an occasional contact of this sort but as a rule the signals are weak, the interference is

BRASS-pounders, message-handlers, rag-chewers—these are terms dear to the heart of all amateurs. In this article Mr. Kruse puts such divisions of the amateur lists into their proper places, and points out that the true experimenter is a combination of all three—and has lots more fun. In the bargain, Mr. Kruse gives some directions about operating the master-oscillator code-and-phone transmitter already described by him in RADIO BROADCAST.

—THE EDITOR.

strong and the contact at best is fleeting, even with good operating skill. Where a contact is recurrent it is almost invariably due to a schedule, careful hunting and breathless listening—plus some "filling-in" by the receiving operator. Working in that manner certain operators, such as Clifford Himoe, who just returned from the McMillan Greenland Expedition, and Fergus McKeever of Lawrence, Kansas, have accumulated extraordinary strings of "calls-exchanged" and not a few international contacts have persisted for weeks or months. These feats have the same relation to the results obtained by an

ordinary operator that Will Rogers' rope spinning has to my attempts—or yours.

THE LOW-POWER MYTH

AT ONE time there existed a state of near-anarchy in amateur radio, occasioned by the installation of high-power broadly tuned transmitters by those amateurs who could afford them. The rest of the congregation was allowed to sit and listen. This was combatted by legislation and by a campaign for low-power records. The expected result of such a campaign followed in the form of a low-power cult which was surrounded by as much exaggeration as the international contacts. We read of this or that station which operates a receiving tube (replaced how often?) at 350 volts and is in "constant" (all newspaper radio contacts are constant) communication with amateurs all over the country (even where there are none). Because superb operators like Mason and Waskey maintained Wilkin's lane of communication with sets of the one-mouse-power class we are asked to believe that the range of a battery-driven set using a receiving tube is 500 or 1000 miles. But, nothing is said of the frequent failures, of the painstaking repeat-repeat-repeat, of the nerve-straining listening, and of the weary hours spent in searching for a lost whisper.

If, indeed, these tiny transmitters were capable of reliable work over distances, then we must suspect the Western Electric Co. of being very badly informed; a 500-mile transmitter manufactured by this company occupies most of a standard boxcar when it is shipped.

It all boils down to this, the range of a short-wave transmitter varies with time, weather, operator's skill, location, interference, and adjustment. The total variation that results is certainly at least as large as 10,000 to 1, and it is quite possible for the same small set to communicate with its antipode with fair signal and

on another occasion to fail entirely to "get out of town." There is also another factor which multiplies the above by another 10 or so. This is the fact that "you can always hear a signal on schedule" if it is even partly readable, through that same signal may have been begging vainly for attention for months past.

THE FRIENDLY "RAG-CHEWER"

SEVERAL years ago when engaged in the process of exploring the wave band of 15 to 100 meters a group of experimenters became very much disgusted with the existing fad for extreme curtness toward any radio activity other than the handling of messages. After listening to a large number of the messages, and handling many of them ourselves, we became convinced that they were mainly of no consequence and could be replaced with profit by tests and friendly conversations. F. C. Beekley, *QST*'s Advertising Manager, and L. W. Hatry, well-known to readers of this magazine, conceived a purely paper organization to be called the "Rag Chewer's Club." In order to become a member of this organization one had to furnish written proof of a 30-minute non-message-handling radio conversation with another amateur station, whereupon there was sent out a membership certificate made up as a burlesque of the I.A.R.U. and A.R.R.L. certificates. It was hoped that, if amateurs could once be induced to assume a human friendliness toward their radio contacts, they would never again lapse to the same machine-made routine. That hope was fulfilled to such a degree that the mailing of the "certificates" became almost a full-time job for one person. Even now, after a number of years, the idea is still alive and one may derive considerable pleasure from a friendly conversation with other transmitting amateurs in various parts of the United States.

—AND THE CALL CARD

SEVERAL years ago Don Hoffman of Akron, Ohio contributed to this picture the idea of sending a postal card as friendly acknowledgement of a radio conversation. His postal card

had the radio call, 8UX, printed across its face in large letters, and other information was pen-written across it.

Within a year the call-card was a fad and every conversation wound up with "Pse send card," or simply "QSL". Shortly after this the owners of active stations discovered that the cost of the cards, and the time to write them, would shortly compel abandonment of radio activity—and as a result they sent fewer of them. Then ensued a violent argument which has raged these three years with no conclusion arrived at. The amateur across the Atlantic especially is not at all pleased with the remarkable lack of consideration shown by his American neighbor who fails to reply to all of the appalling flood of cards and letters from European listening posts which have no transmitters. Meanwhile the varieties of cards grows, but no more colors are available, the limit having been reached in Lawrence Mott's famous Catalina Island series, terminating with an eagle-trimmed card in five colors and gold. Beyond that even the Southern California imagination has not gone.

THE EXPERIMENTER

I PROPOSE to give a considerable space to the experimenter because he is in the most interesting of radio fields, also because he is least organized and least catered to. Let us begin by explaining the seeming contradiction in the preceding sentence.

The experimenter, whether he uses a microphone or key, must say something with it, and unless he uses an outright automatically sent test signal there is no easy way to avoid "rag-chewing" or "message-handling." This causes him to be included in one class or the other although he has no primary interest in message totals or call cards, does not gain any satisfaction from the activities of either of the groups, and intends to stop sending as soon as he has worked out the problem that happens to be under way—which is likely to be anything under the sun from an antenna test to an investigation of the electron distribution in the upper atmosphere during an eclipse of the moon. In addition to this

the experimenter works best in small groups which break up and re-form about various problems, making it very hard to keep track of their performances or to give them any of that entirely proper publicity which will call in new aid.

By tradition organization has centered about message-handling, and personnel or cash has never been placed in back of an attempt to create a coherent experimenter class or a clearing house for information. This has been done for other activities which, in some cases, have received support extending as far as the employment of laboratorians to solve problems by proxy!

All of these things contributed to an unhappy state wherein the experimenter was an outsider, compelled to seek out his own co-workers, handle all his own correspondence without aid and then, if he had energy left to do any effective work, to take his reward in personal satisfaction. The experimenter is usually neither a publicity seeker nor a shirker, but even he resents such an unfair situation. Several years ago, in an attempt to even matters up, I formed the "Experimenter's Section, A.R.R.L." This organization was as loosely put together as the "Rag Chewer's Club" and the motives were not entirely different. The "Section" proposed to issue at intervals lists which would tell all members what work was being done, and by whom, thus facilitating inter-member contacts. To this were to be added occasional outline-suggestions and the results, which were to be circulated in mimeograph form or made into magazine reports when of sufficient interest. Although this work never received more than one fourth of one man's time it really made surprising headway. From it developed the Official Wavelength Station scheme of Don Wallace, the Standard-Frequency transmissions of 1XM and 9XL-WCCO under Lansingh and McCartney, some really worthwhile information on transmission r.f. chokes, a variety of circuit improvements, the fine General Electric and amateur "April tests," much article-material and a considerable contribution toward a changed attitude of the amateur as to experimental work.

IS IT WORTH WHILE?

ONE may question with perfect justice the value of amateur experimental work, since the professionally equipped laboratory seems so much better able to cope with questions than the amateur.

This may be answered either by logic or from the record. First of all, the logic may be taken from (I think) Josh Billings who said, "It's better not to know so much than to know so much that 'aint so." That is the handicap of the trained man seeking new trails—he is too sure of many facts that are not facts, too certain that a whole variety of things cannot be done, too inclined to reason out his course. Furthermore, he cannot escape this tendency, for he is always under the eye of his associates who feel likewise, and usually under the surveillance of an impatient production department which does not want everything tried and but *one* thing finished.

The amateur is not so; he is not required to be logical, or to know any theory from which the result can be predicted. Therefore, he blathers around cheerfully with just the faintest contact with established knowledge, and often he falls over the most amazing and fundamental discoveries. Later the engineer and the physicist and the mathematician will refine and make useful these discoveries. However, it is a fact that a good share of the fundamental things in radio have been discovered with the poorest of equipment and in the face of contrary opinion.

This is, of course, not a suggestion that all established information is wrong. It is, however,

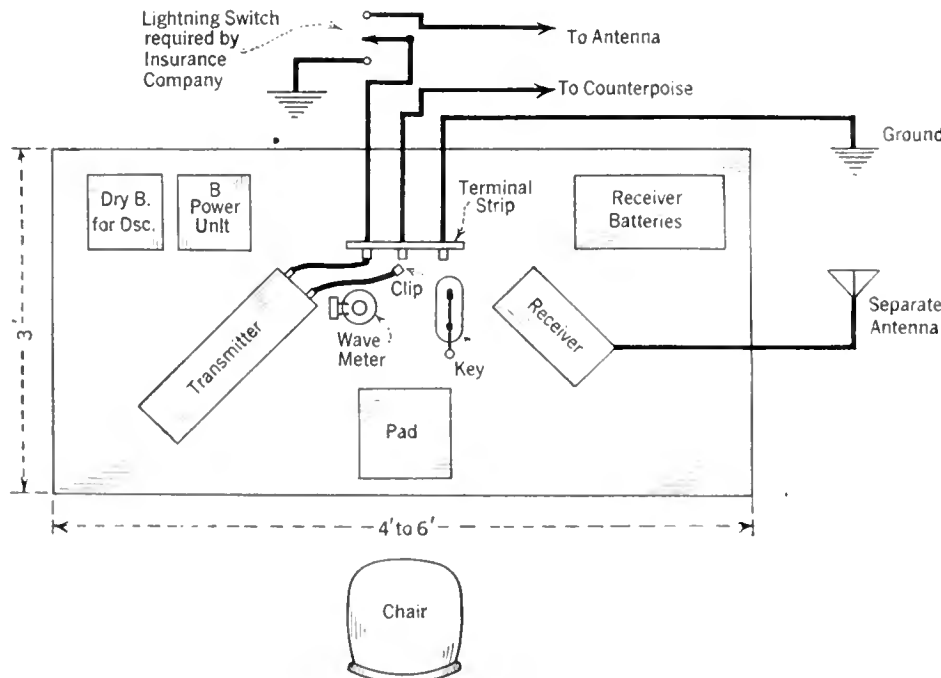

FIG. 1. ARRANGEMENT OF APPARATUS

The table should be about 20 to 30 inches high. If much operating is done the leg room should be entirely free of shelves, batteries or other obstructions. The location of the key is optional, but the transmitter switch should be convenient to the left hand.

an earnest suggestion that the experimenter always be inquisitive and ever ready to try those things that seem to be vague or incorrect. Whatever the conclusions may be which these tinkering and testings give forth, they should be aired. Progress comes from comparison and from the matching of results.

It seems that sooner or later there must exist an agency which may act as a clearing house for the needs and questions of the experimenter in a manner somewhat as adequate as the provision now made for other activities. This will be a rather difficult matter to frame, for it will be required to deal with all manner of interests from the most serious and important to the case of the misguided boy who is trying earnestly and persistently to determine whether Hartley or Armstrong invented the "best sending circuit."

THE INNER URGE

THAT this agency does not exist now will not matter greatly to a real experimenter; when the genuine radio experimenter is interested in a problem time, cash, and correspondence deter him no more than a violent golf fiend is deterred by a pneumonia fog. Similarly I also suspect that such stubborn persistence does produce the best work. At any rate the genuine radio experimenter need not read this discussion, nor will I convert anyone who is not already an experimenter of some sort. The thing is organic, like red hair, and if artificially produced is equally temporary.

THE MESSAGE-HANDLER

AS HAS been suggested above, the handling of amateur radiograms seems to carry less opportunity for developing something worthwhile than do other uses of amateur radio. In the main it serves only to develop operating skill which can then be diverted to worthy ends. The messages handled meanwhile are mostly worthless in the same manner that a copybook is worthless after one has learned to write.

The applications of that operating skill have been advertised so widely that it seems almost useless to mention them. Radio contact with exploring expeditions, occasional emergency work when wires are down, application to military situations, have all been mentioned many times. There exists an Army-Amateur scheme of cooperation as well as a Navy-Amateur scheme, the activity of each differing materially in various territories. The object of these systems is that in case of war there will exist a partly trained reserve.

Recent hearings before the Federal Radio Commission suggest that if no better agreement, can be made between the various interests who "must" have radio for emergency contact we may well consider the possibility of a public-property or corporation-operated radio emergency net whose operators may keep in practice by talking to amateurs. A preliminary tryout of such an idea was instigated some years ago by G. L. Bidwell of Washington and operated by A. L. Budlong for the Pennsylvania railroad. It gave a very good account of itself and I (who began as a skeptic) feel that, with somewhat stronger support, it would have expanded easily into the scaffolding on which a permanent system such as suggested could be erected. Certainly the tryout would have been made easily with amateur stations—and can to-day. It would be a most unhappy matter if instead we were to have a horde of privately owned stations working for their separate owners, having no contact in normal times and hampered by financial affiliations so as to be unable to work in

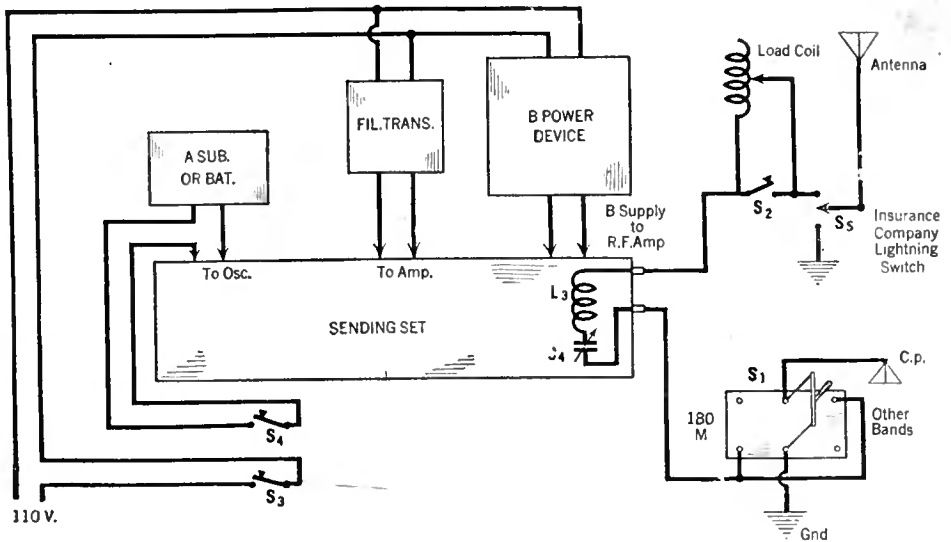

FIG. 2. SWITCHING ARRANGEMENT

Switch 1 changes the antenna so that various bands may be employed. Switch 2 shorts or opens the antenna loading coil used to operate on the 180-meter band. Switch 3 turns on and off the a.c. power input to the transmitter. Switch 4 turns on and off the A battery—if used. It must be kept away from Switch 3, and if a.c. is used in place of the A battery switch 4 is not necessary. Switch 5 is the lightning switch required by the fire insurance company.

the free-handed manner that a good emergency net must base upon.

The suggestion just made, is that certain but ill-defined military value seems to be the main reason for the message-handling game. Expeditions will not continue indefinitely to depend on amateur stations, though they will continue to use amateur operators because they are able to work under limitations of apparatus. International message handling is involved just now in a great bog of diverse opinion from which it may not emerge for a long time, if indeed it emerges.

TEST TRANSMISSIONS

I CANNOT resist a paragraph regarding test transmission. These sendings are typified by the "test number one, test number two, test number three" of the man making circuit adjustments or by the dreary machine-sent "Test 1XAM" or "Test 10A" that has gone out so many times during these years of short-wave exploration. Such transmissions are meaningless to those who have not been informed in advance, except when supplemented by hand-sent or spoken information, but this does not in any way mean that they are out of the way or to be condemned. On the contrary, they deserve a hundred times as much respect as the senseless calling of station after station for the purpose of hastily asking for a card and then jumping to the next station. Such foolery teaches nothing, does not provide satisfaction to the stations so curtly dismissed, and may well step aside for even a machine-sent "test test" which at least represents an attempt to learn.

CONCERNING THE STATION

EVERY man is free to choose which of the foregoing activities he cares to indulge in, but he will find that certain conventions relating to operating and station arrangement apply in each case. One must comply obviously with the legal provisions as to manners of calling and signing to some degree. A certain use of abbreviations is also most helpful and in any case is forced upon one if key operation is employed. These abbreviations fall into two classes, the absolutely arbitrary ones, which are matter of international agreement, and those which are

merely butchered words such as "Xtal" and "Xmitter" for "crystal" and "transmitter" or "Wx" for "weather." Picking these up is not as painful as it sounds. Another class of abbreviations occasionally met is that sort made by phonetic spelling or by dropping vowels, as "sine" for "sign" and "tmrrw" or "Tmw" for "to-morrow." These too dawn on one soon enough.

Station arrangements are suggested in the illustrations herewith and usually a wide departure from these is not advisable. It is really surprising how much more one can accomplish when things are arranged conveniently. Especially one should avoid placing apparatus in cabinets or against walls in such a manner that alteration or inspection requires disconnecting wires. The transmitter as here shown is without a case and this is my preference since a dust-cover made of khaki cloth serves all the useful purposes of a cabinet. If a case is desired it should be made so that it may be removed without disturbing wires. Mere opening of the lid does not suffice.

Other than these generalities it seems destructive to give advice. Such matters as the exact antenna arrangement, the construction of the loading coil, etc. can be decided best by the owner, and useful experience is gained at the same time. If the antenna must be made shorter than was described, perhaps the counterpoise may be made longer, or a different combination altogether worked out to cover the various wavebands. If a loading coil is necessary no exact dimensions need be followed. One may start with the first thing handy—a Dutch Cleanser box for example—and wind it with ordinary annunciator wire. A little loop should be brought out and twisted together every 5 turns until perhaps 40 have been wound. As soon as the loops are skinned one can connect to the lower end of the coil, clip the antenna to one of the loops and, by trying various wavelengths and noting the condenser setting, one can arrive quickly at the correct number to load to the desired 20-meter wavelength. This is quite as effective and much more educational than a set of ready-made directions which might not fit the antenna. At the writer's station the process was timed and it required 20 minutes.



"Our Readers Suggest—"



OUR Readers Suggest—" is a clearing house for short radio articles. There are many interesting ideas germane to the science of radio transmission and reception that can be made clear in a concise exposition, and it is to these abbreviated notes that this department is dedicated. While some of these contributions are from the pens of professional writers and engineers, we particularly solicit short manuscripts from the average reader describing the various "kinks," radio short cuts, and economies that he necessarily runs across from time to time. A glance over this "Our Readers Suggest" will indicate the material that is acceptable.

Photographs are especially desirable and will be paid for. Material accepted will be paid for on publication at our usual rates with extra consideration for particularly meritorious ideas.

—THE EDITOR.

An A. C. Screen-Grid Booster

IN THE August RADIO BROADCAST there appeared the description of "An Extra R.F. Stage For Any Receiver," employing a d.c. screen-grid tube. I was very much interested in this arrangement, but as I desired to use it in conjunction with an a.c. receiver, I thought it logical to redesign the circuit for the Arcturus a.c. screen-grid tube. The altered diagram is shown in Fig. 1. The following is a list of the parts used in the construction:

- 2—Frost ux-type sockets;
- 1—broadcast-range plug-in coil;
- 1—Variable condenser, 0.00035-mfd.;
- 1—Frost fixed condenser, 0.00025-mfd.;
- 2—Silver-Marshall r.f. choke coils;
- 3—Tobe by-pass condensers, 1-mfd.;
- 7—Eby binding posts;
- 1—National dial;
- 1—Front panel, 7" x 9";
- Baseboard or sub-panel;
- Corwico Braidite for wiring;
- Miscellaneous hardware;
- 1—Power Clarostat;
- 1—Step-down transformer, 15-volt;
- 1—Frost strip resistor, 500-ohm;
- 1—Arcturus screen-grid tube, 22-a.c.-type.

The unit is wired to antenna, ground and receiver as indicated. The output post is led to the

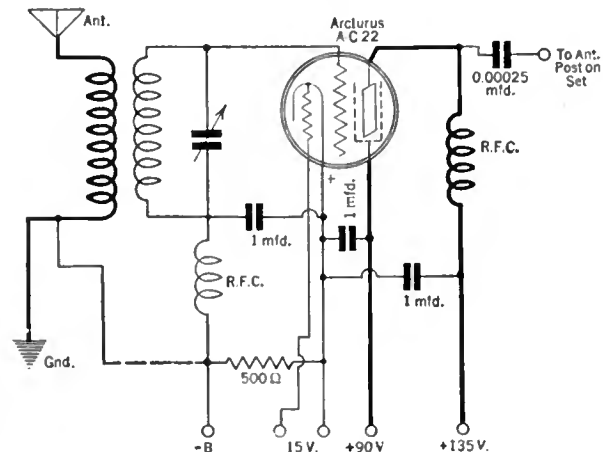

FIG. 1

antenna post on the receiver. An Arcturus 22-type tube is plugged into the socket. The ground is connected both to the receiver and to the booster.

The dial on the booster functions as an additional tuning control.

The power Clarostat is placed in series with the primary of the step-down transformer and is employed to regulate the output to fifteen volts for the Arcturus tube. The voltage is best determined by means of an a.c. voltmeter, however, if this instrument is not conveniently available, the voltage may be adjusted by noting the time lag between the turning on of the current and the heating of the tube to its normal operating temperature. When the voltage is correctly adjusted, the lag will be approximately 30 seconds.

PETER L. JONES, Boston, Mass.

Work Bench Clamp

THE presence of wires indiscriminately strewn about the test bench is hardly conducive to efficient work, to say nothing about the possibility of short circuits, wrong connections and general



FIG. 3

lack of order. I have found it decidedly worth while to equip my test bench with several simple clamps designed to hold the various wires to the table.

A simple clamp for this purpose is shown in the picture, Fig. 3. It was assembled from odds and ends out of the junk box.

A small strip of thick wood provides the base. Near one end a recess is filed out for the cable. The latter is held in position by a narrow strip of ebonite which acts as the upper jaw.

Slightly off the center, a countersunk hole is drilled in the wood block for a 3/8-inch screw, and the ebonite strip is forced down by a small wing nut. Although a spring washer is used between nut and ebonite strip, the latter will have a tendency to turn when the nut is tightened. To prevent this, the other end of the ebonite strip has

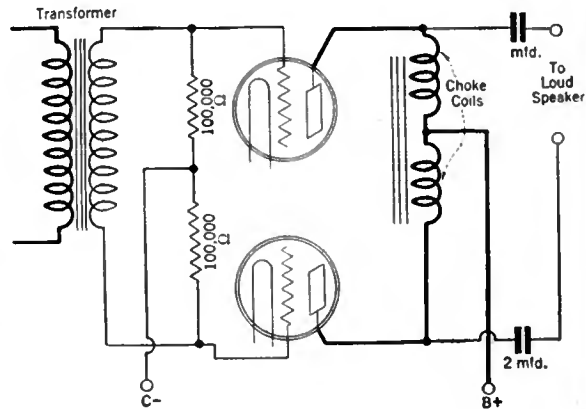

FIG. 2

been slotted; in this slot lies a stop—a nail driven into the wood block and snipped off about 3/8" above the surface of the latter.

C. A. OLDROYD, Lancs, England.

Push-Pull with Standard Transformers

FOR clear and undistorted output, with abundant volume a well-made push-pull amplifier is the standard of comparison.

The transformers specially made for such circuits have a center-tapped secondary winding in the first stage, and a center-tapped primary winding in the output stage. Yet a standard audio transformer may be used with excellent results if an external center-tap is provided, as indicated in Fig. 2.

Two 100,000-ohm resistors are connected in series across the secondary. The grid bias is applied at the central junction of the two resistors. The value of the resistors is not critical, and slightly higher or lower values may be used if the experimenter happens to have them at hand.

The only other special part needed for a push-pull amplifier is the output transformer or a center-tapped output choke through which the B current reaches the plates of the power tubes.

A commercial choke may be used in this position, but the same results can be secured by using two standard chokes connected in series.

The inner turns of the two chokes are joined by a connecting lead, to which the B-plus lead is wired. Two fixed condensers are connected as shown in Fig. 2 to keep the loud-speaker windings at a low potential.

C. A. OLDROYD, Lancs, England.

Home-made Soldering Lug

RUNNING out of soldering lugs in the midst of a radio construction job, I twisted the loose ends of the stranded hook-up wire together and bent them in the form of a hook. To reinforce the stiffness of the lug it was tinned thoroughly. While the solder was still soft, the hook was flattened with pliers, thus providing a better contact surface.

This lug is no harder to make than it is to solder the wire to a conventional lug—and it costs nothing.

EDWARD PIRANIAN, Philadelphia, Pa.

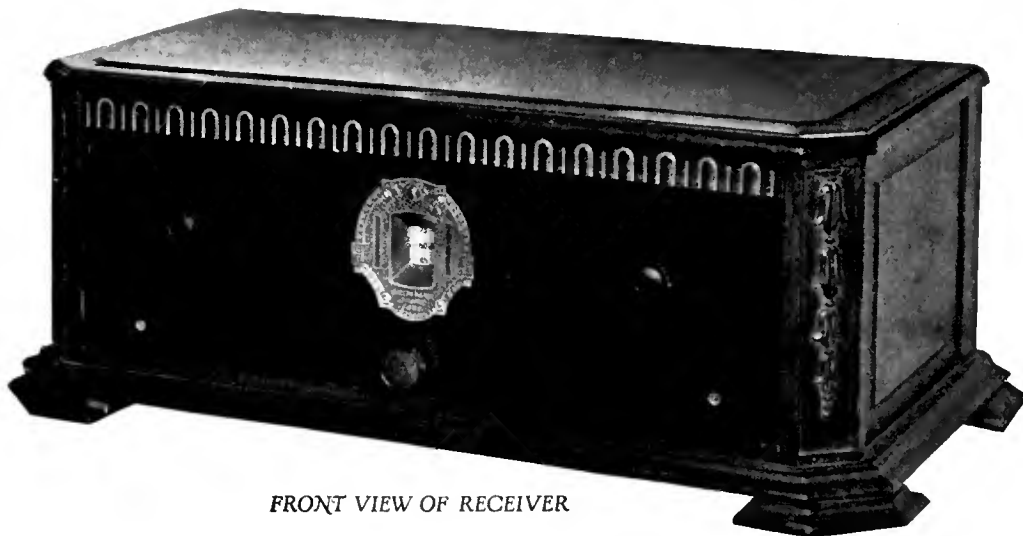

FRONT VIEW OF RECEIVER

The New A. C. Screen-Grid Browning Drake Receiver

By GLENN H. BROWNING

Browning Drake Corporation

THE Browning-Drake Kit-Set has enjoyed a continued popularity since its introduction a number of years ago, doubtless due to the efficiency of the radio-frequency transformers, combined with the simplicity of the circuit in which they were used. During this time some slight improvements have been made.

With the introduction of the screen-grid tube, the problem of designing a one-stage tuned radio-frequency amplifier was attacked again from an analytical standpoint and an extremely efficient transformer was developed for this type of circuit. The problem of obtaining selectivity and gain in a radio-frequency amplifier employing a screen-grid tube differs considerably from that encountered when using a 199- or 201A-type tube. This is due to the inherent electrical characteristics of the tubes themselves. For instance, the 201A-type tube has a plate impedance of approximately 12,000 ohms, and an amplification factor of 8, while the screen-grid tube has approximately 400,000 ohms of impedance with an amplification factor of from 150 to 300. With the 201A-type maximum gain could be obtained easily by the proper number of turns on the primary, together with a normal coefficient of coupling which was about 0.5. This, together with a low-resistance secondary, resulted in a gain of about 12 to 15 per stage. However, when using this tube careful neutralization, even in a single-stage amplifier, was necessary to obtain the best results. The primary purpose in the design of the screen-grid tube was probably to make the capacity between plate and grid so small that neutralization was usually unnecessary. In interposing the screen-grid between control grid and plate, high amplification in the tube itself resulted as well.

PROBLEMS OF DESIGN

THERE are two ways of obtaining radio-frequency amplification under the new condition imposed by the screen-grid tube, i.e., by an auto-transformer (tuned impedance), or by

the usual tuned radio-frequency transformer, consisting of a primary and secondary winding. These have been discussed at some length in a previous article in this magazine and will not be dwelt on here. It is sufficient to say that tuned impedance has the advantage of slightly more amplification per stage while the transformer gives greater selectivity. The design of such a transformer, however, is not a simple matter by any means. With the increase of plate resistance that the screen-grid tube has over the 201A type, the turns on the primary of the radio-frequency transformer should be increased a great deal for maximum gain, or the coefficient of coupling must be increased, or both. Unfortunately, there is a very definite limit to the number of turns which may be used on the primary of the transformer. This limit is determined by the distributed capacity and inductance of the winding itself, coupled with the capacity placed across it due to the plate to ground capacity of the tube used as the radio-frequency amplifier.

These two capacities tune the primary to a definite wavelength, and if this wavelength is 200 meters or above, the transformer as a whole will tend to pass a signal coming in on this wave no matter where the secondary is tuned. In designing a transformer for the screen-grid, the high plate resistance means that primary turns should be increased, but the plate to ground capacity is increased over the 201A type of tube by a factor of three or four times, due to the proximity of the screen-grid to the plate. Therefore, it is essential to increase the coefficient of coupling as much as possible.

Some months ago the writer started to determine just how this coefficient of coupling could be increased from its normal value of about 0.5 to as great a value as possible (the maximum theoretical value is 1). The result was that, with a short winding length for the secondary and a slot wound primary placed in about $\frac{1}{4}$ " from the low-potential end of the secondary, the coefficient of coupling in-

creased to 0.91. Thus, with this coefficient of coupling and placing as many turns on the primary of the radio-frequency transformer as possible, consistent with keeping its natural period below 200 meters, a transformer for the screen-grid tube was developed, which has an extremely good gain. However, it might be stated that as far as the writer has been able to determine, it is impossible to get the maximum theoretical gain at broadcast wavelengths from the screen-grid tube because of the limitations imposed on the number of turns on the primary winding of the radio-frequency transformer.

THE SELECTIVITY

THE selectivity of the transformer under discussion, as well as the amplification, is considerably better than in the case of using the 201A-type tube as a radio-frequency amplifier. There are two reasons for the increase in selectivity. First, other factors being equal, the selectivity is better in a radio-frequency transformer when the gain is below maximum. Second, for a given amount of gain the higher the coefficient of coupling the greater the selectivity, provided the resistance of the secondary winding of the transformer is approximately the same in both cases. This later statement will probably not be evident but can be proved mathematically or can be shown readily in laboratory measurements.

The 1929 Browning-Drake Assembly employs one stage of tuned radio-frequency amplification with either a.c. or d.c. screen-grid tubes with the transformer described. Tickler feed-back is used in the detector as previously. No neutralization or shielding is necessary for efficient operation. The antenna system has been changed to use an untuned primary. This is because the coefficient of coupling between primary and secondary has been increased to 0.91 so that a primary is as effective as direct coupling and aids somewhat in making the kit absolutely single control. The 0.0001-mfd. condenser (C_1) is con-

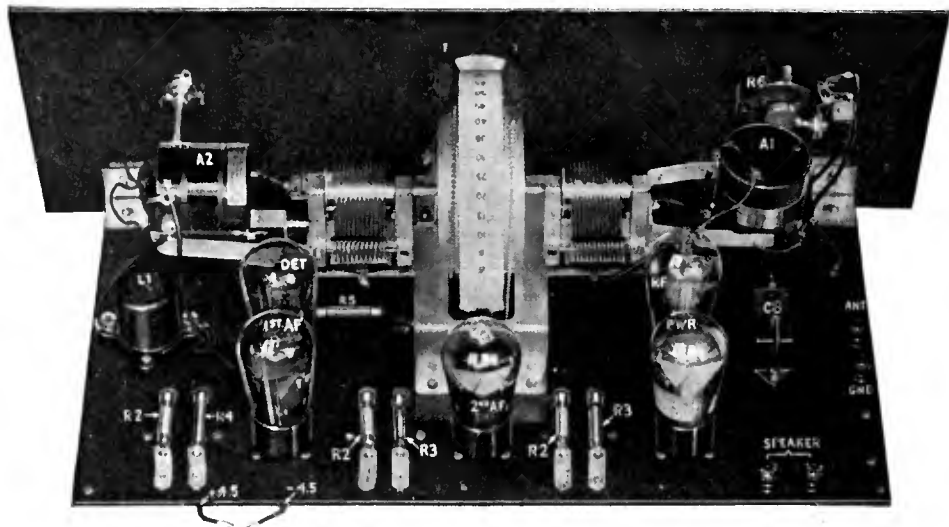

VIEW OF RECEIVER SHOWING ARRANGEMENT OF APPARATUS

nected in series with the primary in the antenna circuit so that the primary is never tuned by the capacity of any antenna length within the 200-550 meter band.

Three stages of resistance-coupled audio amplification are recommended, although other types may be used if desired.

It is unnecessary here to give constructional details for the kit-set as these may be obtained directly from the Browning-Drake Corporation, who manufacture the 1929 Browning-Drake A.C. Shield Grid Kit.

The Kit-Set has been carefully designed by mathematical and laboratory methods, and the writer feels that it is the best Browning-Drake ever presented to the public. Not only does it outperform all previous models from the standpoints of selectivity and sensitivity, but its tone quality is as nearly perfect as can be obtained at the present stage of the radio art. Coupled with this is the feature of simplicity of operation, due to its being absolutely single control.

LIST OF PARTS

A COMPLETE list of the apparatus employed in the construction of the A.C. Screen-Grid Browning-Drake Receiver follows:

- A₁, A₂ One Browning-Drake 1929 kit (a.c. screen-grid type);
- L₁, L₂ Two radio-frequency transformers;
- R₁ Three Browning-Drake center-tapped resistors;
- R₂ Three Aerovox or Durham resistors, 0.05-megohm;
- R₃ Two Aerovox or Durham resistors, 0.1-megohm;
- R₄ One Aerovox or Durham resistor, 0.5-megohm;

- R₅ One Aerovox or Durham resistor, 8-megohm;
- R₆ One Frost volume control and 110-volt switch;
- R₇ One Yaxley resistor, 1000-ohm, type 71,000;
- R₈ One Aerovox resistor, 2000-ohm, type 992;
- C₁ One Aerovox or Sangamo moulded fixed condenser, 0.0001-mfd.;
- C₂, C₃, C₄ Three Aerovox or Sangamo moulded fixed condensers, 0.001-mfd.;
- C₅ One Aerovox or Sangamo moulded fixed condenser, 0.00007-mfd.;
- C₆ One Aerovox or Parvolt by-pass condenser, 1-mfd.;
- C₇ Three Browning-Drake special amplifier coupling condensers, 0.1-mfd.;
- C₈ One Aerovox moulded condenser, 0.5-mfd.;
- Two Eby vacuum-tube sockets, UY-type;
- Four Eby binding posts (Ant., Gnd., Speaker and Speaker);
- One Browning-Drake Foundation Unit consisting of drilled front and base panels with amplifier sockets and resistor mounts, twisted a.c. filament wire, connecting cable and all hardware.

The total cost of the parts in the above list is \$59.45.

The additional apparatus required for placing the receiver in operation follows:

- One screen-grid tube, a.c.-type;
- One detector tube, UY227-type;
- Two amplifier tubes, UX226-type;
- One power tube, 171A-type;
- Filament transformer, B-power unit, aerial, ground, loud speaker, etc.

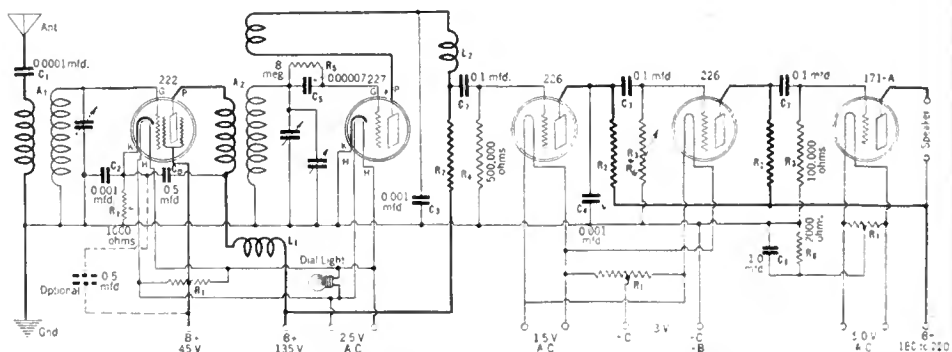

FIG. 1. COMPLETE SCHEMATIC DIAGRAM

Book Reviews

"A TREATISE ON 25 TESTING UNITS FOR SERVICE MEN." Published by Radio Treatise Company, New York City, 26 pages. Price—\$1.00.

THE title of this book defines clearly and definitely its scope and purpose. In the description of the various testing units the author has also given considerable general data on how to test receivers. The service man, endeavoring to service a radio receiver by simply following instructions, has before him a task comparable to that which Diogenes had. To successfully service a set one needs, besides the mechanical tools of the trade, a clear understanding of how receivers and set-testing devices work. The educated service man will not hesitate to try this strange food—for an understanding of why the wheels go round is strange to many service men.

The testing devices described in this book are many and include the following:

Tube Reactivator and Filament-Emission Tester.

Vacuum-Tube Bridge, by which one can measure the amplification constant and plate impedance of a tube.

Tube Tester, for measuring the electrical characteristics of all types of a.c. and d.c. tubes.

Voltage Tester, for measuring the A, B, and C potentials in any modern receiver.

Oscillators, both audio- and radio-frequency, to be used as local sources of signals in servicing sets or in making laboratory tests.

Laboratory Oscillators, producing frequencies throughout the audio range and up to about 300 kilocycles. This is useful in measuring audio-frequency apparatus intermediate-frequency transformers, etc.

Indicating Devices, which include descriptions of several vacuum-tube voltmeters.

On page 17 is described a vacuum-tube voltmeter of the design generally known as the "slide-

back" type, in which the unknown voltage is balanced against the C-battery voltage. It is not generally the case, however, that the unknown voltage is equal to the change in grid voltage, although the author states that such is the case. When very large voltages are being measured the slide-back method can be used with quite a small error, but with small voltages, such as one frequently must deal with in amplifiers, the slide-back method, in the reviewer's opinion, is quite inaccurate. However, the service man generally is interested in qualitative rather than quantitative values and in such cases this type of vacuum-tube voltmeter probably can be utilized satisfactorily.

As we indicated previously, the appeal of this book is confined generally to the dealer or service man, although many set builders should find the constructional data on laboratory instruments very helpful.

—H. E. R.

An A. C. Band-Pass Screen-Grid Receiver— The Master “Hi-Q 29”

By WILLIAM E. BARTON

Hammarlund-Roberts, Inc.

FOR as many moons as the oldest radio editor can remember, writers and engineers have deplored the fact that one cannot have both selectivity and fidelity—and yet nothing much has been done about it. On the one hand, we have receivers which may get all the audio notes in proper proportion, but which, so far as selectivity is concerned, are as broad as the proverbial barn door. On the other hand, we have receivers which, to use an advertising phrase, are as sharp as a knife blade, but which—and advertising writers say nothing about this fact—get few notes above 3000 cycles. And there you are. You may pick and choose, but you can't have your loaf and eat it.

A radio receiver first of all must select the program you want to listen to, and then must amplify the audio tones to the level desired, whether it be for head-phone reception or full loud-speaker volume, usually the latter. But if, in the process of selecting, half of the audio tones you want to hear are lost, no amount of audio amplification will bring them back again in their proper proportion. There will be plenty of “lows” to be sure, lots of the bass drum—unharmonious instrument—but few of the human-like notes of the violin.

And so in a congested district where broadcasting stations are placed far enough apart not to bother each other, but close enough together to prevent any “getting out,” people built receivers which were not very selective, and so the quality was good. Fans outside the large cities, however, had a different problem. Surrounded by stations, all over 100 miles away, the receiver had to have selectivity enough to cut out a geographically near-by station which might be poor in quality in order to receive a good station only 10 kc. away from the nearer station. No wonder side bands were clipped. No wonder few notes above 3000 cycles were received.

Up until about a year ago such a dilemma as this existed in every constructor's mind—should he build a selective receiver, one that would get out, or should he be satisfied with local broadcasting and build a broadly tuned receiver? In most cases a compromise was difficult to effect. Then, at a meeting of the Institute of Radio Engineers, Dr. F. K. Vreeland gave his paper of band-pass tuning which promised not only more selectivity but greater fidelity of response as well. This started many engineers thinking and remembering their text books and wondering why they hadn't thought of Dr. Vreeland's scheme themselves. For the truth must be told, Dr. Vreeland called to mind the old system of tuning two circuits to the same frequency and then coupling them closely enough together that



THE HI-Q IN A COMBINATION
PHONOGRAPH-RADIO CABINET

THE theoretical background of the 1020 model of the Hi-Q receiver, as outlined in October RADIO BROADCAST, is amplified in this article from the Hi-Q organization. In the Laboratory, as tested under average conditions, the receiver seemed to have considerable r.f. amplification, the selectivity was good, and the fidelity of response was excellent. The completeness with which the r.f. circuits are filtered probably has much to do with the stability, and simplicity of operation. There are no trick adjustments.

There is one interesting point which is not mentioned in this article, and about which we hope to present data soon. This is the fact that the shape of the response curve depends upon the frequency—that is, the curve will be one thing at 500 kc, something else at 1500 kc.—when the circuits are coupled by inductance, capacity, or mutual inductance. Just what this effect is, in the present receiver, was not apparent in the Laboratory. At the top and bottom of the broadcast-frequency spectrum good response was obtained. Perhaps the receiver had been adjusted somewhere in the middle of the band so that at the two ends it still had a band-pass circuit characteristic.

—THE EDITOR.

the response curve no longer looked like a steep mountain, but like twin peaks side by side. It no longer had gently sloping sides down at the interference-frequency region, but a sharp cut-off.

And what good is such a curve, you may ask? Why have a broad top and steep sides. The answer is the reply to the prayers of engineers and those who want more selectivity and more fidelity of response. At the top of the curve—where the audio tones are—a broad flat plateau exists, at the sides of the curve—where interfering stations are—there is a steep precipitous drop in response.

BAND-PASS FILTER CURVES

LET us look at Fig. 1 which represents engineering data on the Hammarlund Roberts “Hi-Q 29,” a receiver making use of the time-honored method of obtaining the flat-topped response curve described above. In the case of the single coil and condenser tuned to 1000 kilocycles, the top of the curve is peaked markedly, and if, as is usual, a little regeneration creeps into the amplifier, this peak becomes even more marked. The dotted line represents the response or resonance curve of a circuit with a resistance of about 5 ohms at 1000 kc. a low-loss circuit. At 2000 cycles the curve is beginning to droop and at 5000 cycles the response has been reduced

to only 60 per cent. of the response at, say, 100 cycles. Now look at the full-line curve which represents the band-pass tuning arrangement. This is laboratory data on a single r.f. stage of the “Hi-Q 29” receiver. At 2000 cycles the curve has not even begun to drop, and at 5000 cycles the loss is only 10 per cent.

At the bottom of the curves in Fig. 1 other interesting things may be noted. The dotted curve shows a response at 20 kc. off resonance of 20 per cent. In the case of the Hi-Q stage, however, the loss is 90 per cent. which, in a two-stage affair, where the loss is squared, gives a response of 1 per cent. instead of 4 per cent. for the simpler circuit.

So far so good, but how is it possible for a receiver to be selective and still have good fidelity of response? Fig. 2 is the diagram of a single transformer-coupled stage of r.f. amplification which has the proper electrical characteristics to give a curve like that of Fig. 1 (dotted-line curve). The less the resistance in this circuit, the greater the amplification, and the greater the loss to the high audio tones. Now let us contrast this circuit with the more complicated one in Fig. 3, which is the arrangement used in the Master “Hi-Q 29” receiver. Here, again, we have a transformer-coupled stage of r.f. amplification, but both the primary and secondary windings are tuned—and they are tuned to the same frequency. In fact the primary and secondary coils

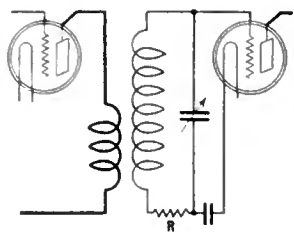

FIG. 2

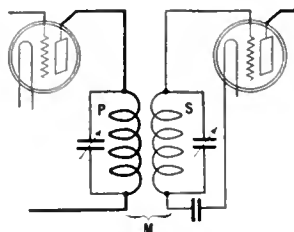

FIG. 3

and condensers are identical. The lower the resistance of the coils, the greater the amplification, but the side-band clipping depends upon the coupling between the coils which can be adjusted mechanically.

Theory states, and if you care to look it up you will find it in Pierce's *Electrical Oscillations and Electrical Waves*, pages 73 to 85, or Morecroft's *Principles of Radio Communication*, pages 119 to 136, that when two such circuits are tuned to the same frequency, and coupled electrically to a sufficient degree, the circuit no longer responds to the frequency to which the individual circuits were tuned but to two new frequencies which are displaced from the single-circuit frequency a certain amount, depending upon the coupling. In Fig. 4 may be seen two extremes of coupling. In one case (A) the coupling is very loose, so that a single sharp peak shows up, and with this adjustment little energy is transferred from primary to secondary. In the other case (B) the coupling is too close. Two peaks arise with a sharp dip between. Somewhere between these two degrees of coupling is found the type of curve we want, broad at the top and steep at the sides.

COUPLING ADJUSTMENT

THE coupling, then, is the important thing, and fortunately it can be controlled and adjusted until the desired type of response curve results.

So much for the theory of the Master "Hi-Q 29" receiver. It employs a band-pass filter type of r.f. amplifier using screen-grid tubes (a.c. or d.c.) which selects and amplifies but which clips side bands far less than the conventional low-loss coil transformer of the type used in nearly all present receivers. The detector of the receiver is conventional—a grid leak and condenser type. The audio amplifier is composed of two stages coupled with high-grade audio transformers. The last tube is a 171 type, and, as may be seen in the picture, sufficient room is allowed on the chassis for mounting an output device, or if desired a push-pull amplifier.

This chassis is made of steel, plated with cadmium which prevents rust, and has almost the same dimensions as last year's model. The individual stage coils and condenser are housed in aluminum boxes. The tubes themselves are between the shields and shielded leads make the connections from the control grid to the apparatus within the boxes. The volume control governs the voltage on the screen grids. The antenna stage is tuned separately from the other circuits,

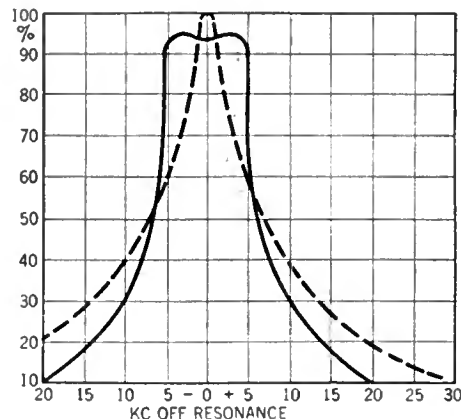

FIG. 1

and an additional tapped arrangement on the coil permits some range of selectivity control in the antenna stage. Careful shielding is necessary in this circuit where the primary windings of the radio-frequency transformers are tuned. Any feedback coupling would introduce serious difficulties. For this reason the stage shields used are tight fitting, and the wires which connect coils to the tubes are enclosed in screening which is supplied as part of the Hi-Q kit.

So much for the electrical and mechanical properties of the new receiver. Complete data on how to build, adjust, and operate the set are obtainable from RADIO BROADCAST or from the Hammarlund-Roberts organization. The list of parts on the next page is the list specified by the manufacturer. The coils and mountings are special, and difficulty would be had in at-

tempting their construction. Their essential dimensions are given in the complete circuit diagram, however, so that if the constructor desires he may try his hand at it.

What does the receiver do on the air? Just as an automobile manufacturer sends his product out over the road to see how long it will run without falling apart, how fast it can go, or other tests which the user probably never will desire to make himself, so must the radio set manufacturer make his receiver go through a "road test." The following is a report of such a test made for the Hi-Q organization.

In a small town on Long Island, about 8 miles from WEAf, 30 miles from WJZ and 10 miles from WABC we set up the model using Arcturus a.c. screen-grid tubes in the r.f. circuits, Arcturus type 46 and 48-tubes in the detector and first a.f. circuits, and a Cunningham type 371A tube in the power a.f. stage. The antenna was used ordinarily for a 40-meter amateur transmitting station and was about 60-feet long with the lead brought in from the middle. The two ends were about 45 feet above ground, and the set was operated in a second-story room. The set was not grounded—this was accidental, not intentional—and the selectivity and sensitivity might have been improved if proper grounding had been looked after. The night was October 13, the beginning of the winter season of heterodyne notes and ether jamming.

The stations whose calls were identified definitely came in with a more than ample volume for a large Peerless dynamic speaker in a three-foot baffleboard. WLS and WOP in Chicago were very strong. WIP in Philadelphia was very loud—ordinarily he is difficult to hear on Long Island—and the old stand-by's, KDKA and WGY were roaring in. WHAM at Rochester was easy to get, so were WBZ, WTAM, and one station between WEAf and WJZ was separated easily from these

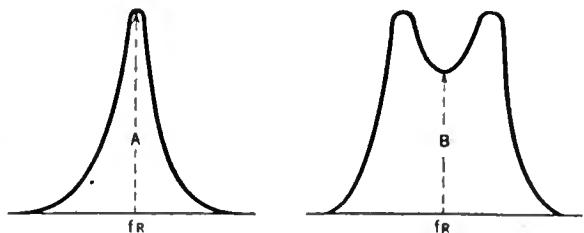

FIG. 4

two near-by stations. It was probably WRC in Washington. All in all, the writer had an enjoyable evening and predicts much fun for the owner of such a receiver.

OTHER MODELS

THERE are two models of the Master Hi-Q receiver. One is designed for d.c. tubes, and the circuit diagram for it was published in October RADIO BROADCAST, page 343. The other is for a.c. tubes and the diagram is published herewith. This receiver uses Arcturus screen-grid tubes which require a 15-volt filament supply. The Thordarson power-supply equipment illustrated in Fig. 5 supplies this voltage as well as the other filament plate and grid voltages for the operation of the entire receiver.

The foundation unit supplied by the Hi-Q organization includes the resistors R₆, R₇, and R₈ which are the center-tapped 50-ohm units for the first tube. And small fixed resistors used to filter the screen-grid circuits.

The picture of the receiver which appears on the next page shows several interesting features of its mechanical construction. One of the sides of the middle shield has been removed to show how

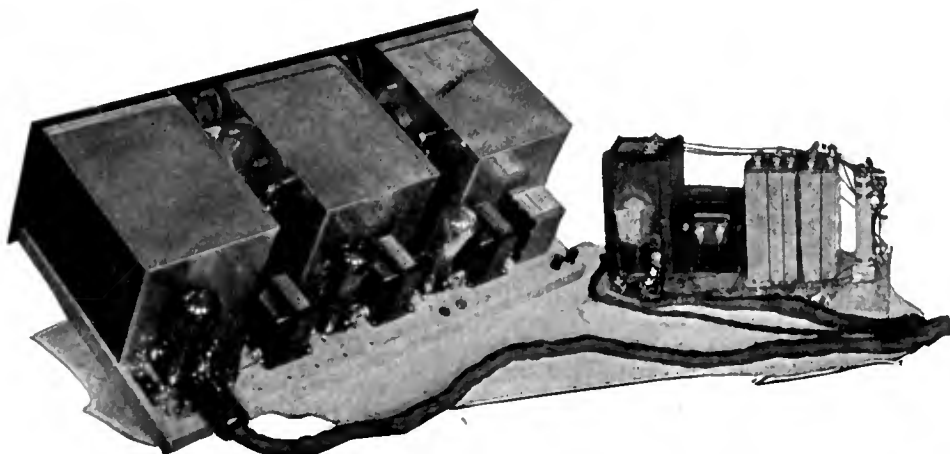

REAR VIEW OF HI-Q AND POWER UNIT

the two coils of the transformers are located, one above the other and on opposite sides of the insulating strip on which they are mounted. The position of the coils is fixed in the factory so that the desired coupling is attained. The double-condenser system, one condenser for each coil, is easily discernible, as well as the fact that all of the condensers, except the antenna tuning capacity, are controlled by a single dial. The antenna stage is, of course, in a separate shielded compartment, and consists of a high-gain, low-loss coil with taps on it so that antennas of various lengths can be accommodated. In operation the proper antenna tap should be found by trial and then the top of the compartment screwed down tightly, thereby reducing unwanted coupling to near-by fields to a minimum, and effectively sharpening the tuning of this stage when operated in the vicinity of several local stations.

The list of apparatus employed for the construction of the Master Hi-Q a.c. receiver follows:

- A₁, A₂, A₃ One Hammarlund Hi-Q 29 coil set;
- C₁ to C₅ Five Hammarlund midline condensers, 0.00035-mfd., type ML-17;
- C₆ One Sangamo fixed mica condenser, 0.00025-mfd.;
- C₇ One Sangamo fixed mica condenser, 0.001-mfd.;
- C₈ to C₁₃ Six Parvult by-pass condensers, 0.5-mfd., series 200;
- C₁₄ One Parvult by-pass condenser, 4-mfd., series 200;
- L₁, L₂, L₃ Three Hammarlund r.f. choke coils, type RFC-85;
- L₄ One Thordarson choke coil, type 106;
- R₁ One Carter "Hi-Pot" Potentiometer, 100,000-ohm, Type 11;
- R₂ One Durham metallized grid resistor, 1.5-megohm;
- R₃, R₄ Two Durham metallized resistors, 0.25-megohm;
- T₁, T₂ Two Thordarson a.f. transformers, type R-300;

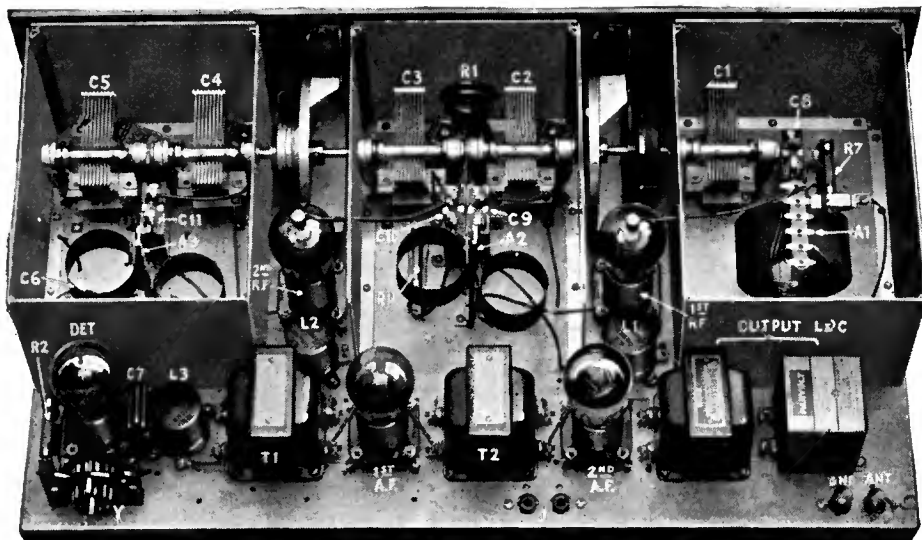

VIEW OF HI-Q WITH SHIELD COVERS REMOVED

- Y One Yaxley cable and connector plug, 12-wire;
- Two Hammarlund knob-controlled drum dials, type SDW (Walnut);
- Five Benjamin Cle-Ra-Tone sockets, type 9040;
- Two Eby binding posts, engraved;
- One Hi-Q Foundation Unit containing one drilled and engraved Westinghouse Micarta panel, three complete aluminum shields, one drilled steel chassis, shafts, one binding-post strip, Fahnestock clips, fixed resistor units R₆, R₇ and R₈, resistor mounts, brackets, clips, wire, screws, nuts, washers, and all special hardware required to complete the receiver.

- C₁₅ One Parvult by-pass condenser block, 3-mfd.;
- C₁₆ One Parvult filter condenser, 1-mfd., series 200;
- C₁₇ One Parvult filter condenser, 2-mfd., series 200;
- C₁₈ One Parvult filter condenser, 4-mfd., series 200;
- C₁₉ One Parvult filter condenser, 2-mfd., series 400;
- P One Thordarson power compact, type R-171;
- R₅ One Electrad "Truvolt" resistor, Hi-Q-type;
- T₃ One Thordarson filament transformer, 15-volt, type T-2610;
- S. S. One Pair of Yaxley insulated phone-tip jacks, type 422.

The total cost of the parts required for the construction of the receiver is \$109.45.

The following is a list of the parts used in the construction of a power unit for the Master Hi-Q a.c. receiver:

The total cost of the apparatus employed in the construction of the power unit for the Hi-Q is \$41.60.

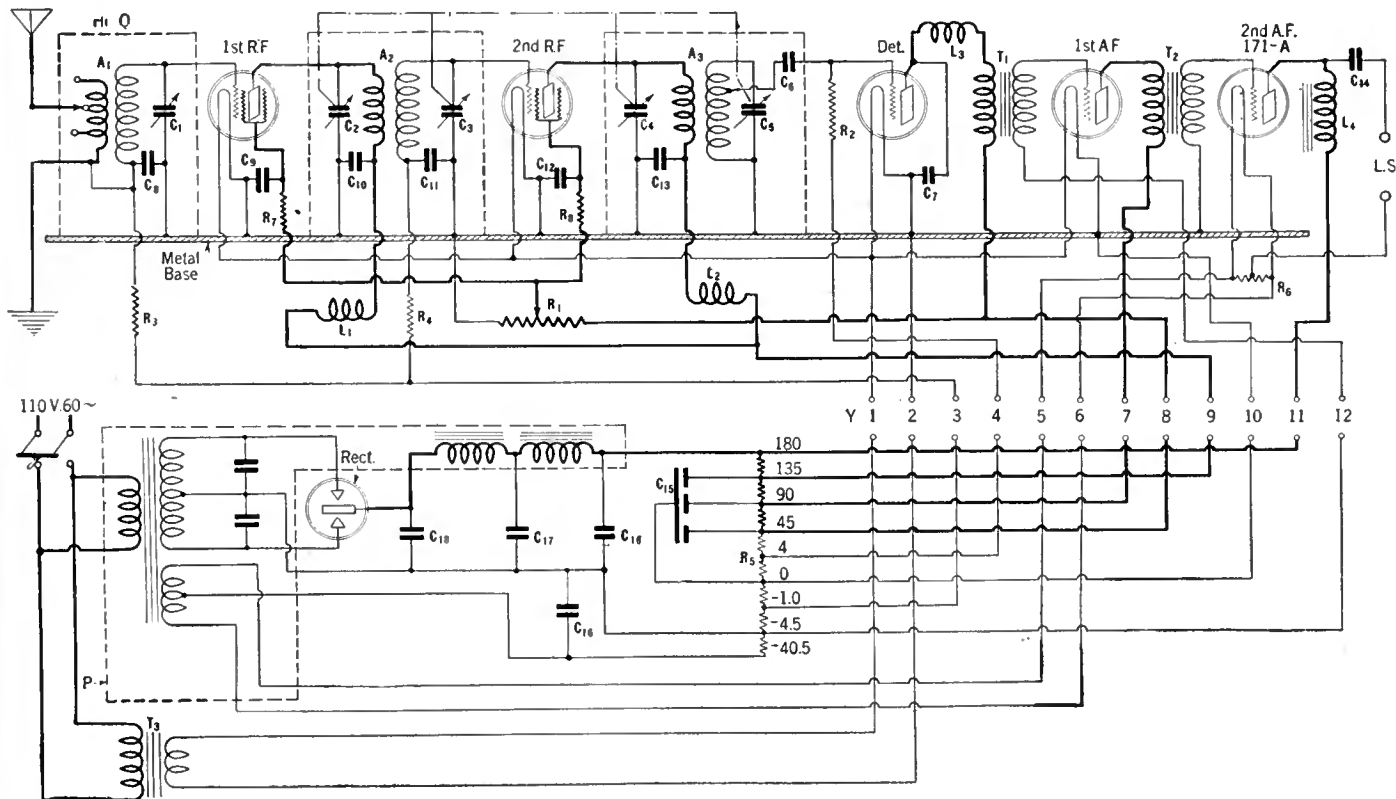

FIG. 5. THE COMPLETE SCHEMATIC DIAGRAM OF THE MASTER HI-Q RECEIVER TOGETHER WITH THE CIRCUIT OF A SPECIAL POWER UNIT DESIGNED FOR THE RECEIVER

New High-Voltage Metallic Rectifiers for B-Power Units

By J. GEORGE UZMANN

THE rectifier described in this article is a new device designed for use in Majestic, Thordarson R-171, or other similar types of B socket-power devices. This new unit was made possible only after many months' research and experiment with metallic (electronic) rectifier systems by Harry Shoemaker, Chief Engineer of Elkon, Inc., New York City. While the underlying principles of contact rectification (into which class falls this rectifier) perhaps are not new, still the pitfalls were many, particularly when dealing with potentials in the order of 350 volts many problems arise that must be solved.

Any means of high-voltage rectification must be comparable in performance to that produced by modern high-vacuum filament-type rectifiers. This new rectifier, known as the new Elkon type EBH, is the first of a series of high-voltage rectifiers. The pictures show the new Elkon EBH rectifier in assembled and partially complete forms; it is $5\frac{1}{8}$ inches in height, has a diameter of $1\frac{3}{4}$ inches and weighs approximately 16 ounces. The use of a standard tube base permits its use in the same way as any other ordinary type of rectifier—gaseous or thermionic. Since the unit is nearly all metal and contains no glass envelope or supporting structure it is obvious that little or no damage can come to it. The outer aluminum casing serves essentially as a heat radiator.

The actual rectifier consists of a large number of couples made up of cupric sulphids in contact with an aluminum-magnesium combination. These coupling elements have all the appearances of a large number of washers, and are $\frac{1}{8}$ -inch in diameter. In proper combination they are assembled into four stacks, and then by means of clamping collars are forced together hydraulically to a predetermined pressure. The four main sub-assemblies are then inter-connected so as to fit electrically the circuit for which the rectifier is intended; thus the base-plug permits supplying

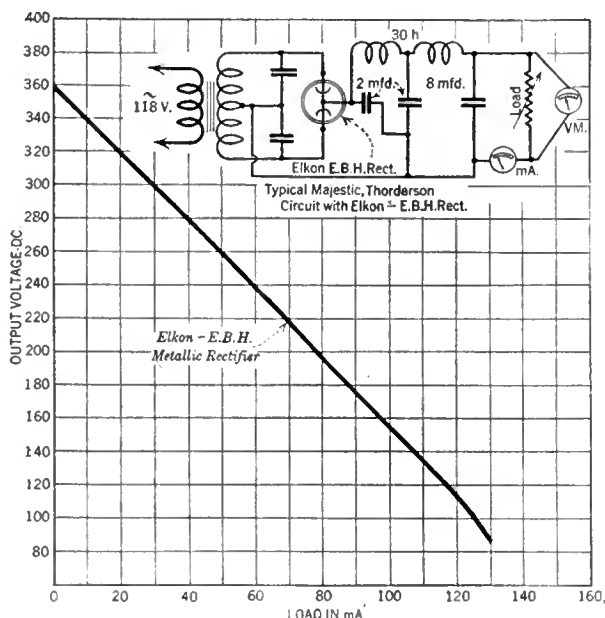

FIG. 1

THE article on this page presents the description of a new high-voltage metallic rectifier which may exert a great influence on the design of power-supply devices of the future. The data were prepared by J. George Uzmann at the request of Elkon, Inc.

—THE EDITOR.

the high voltage raw a. c. to the coupling units, and finally taking off the full-wave rectified d. c. output component.

The process of manufacture, treatment and aging, around which the device evolves, makes a story in itself, but space does not permit a lengthy description. In the complete assembly 240 pair of "couples" are employed, and, since the maximum impressed voltage per anode is 350 r. m. s. (700-volt total), it is evident that the couples are designed for a potential pressure of approximately 3 volts r. m. s. per pair of couples. The operation of the EBH rectifier is based upon the physical fact that when relatively high electropositive and electronegative bodies are brought into proper contact, and current passed so that an electrochemical reaction takes place at their junction, an asymmetrically conducting film is formed at the junction which permits the passage of current in one direction only. These films can be formed and continuously maintained when proper electrical and physical conditions prevail at the junction.

The load characteristic of a typical B-power unit using the Elkon EBH rectifier is given in Fig. 1. It should be noted that the slope is very uniform from no load to maximum load, with but a slight curvature at the extreme ends. For gas tube rectifiers the curve would show the output voltage rising abruptly within the no load area. The output voltage of an EBH recti-

fier is about 20 volts lower, over the useful ranges, than that of a gaseous rectifier.

An important feature of these new metallic rectifiers, according to the manufacturer, is that they have a life of approximately 5000 hours as compared to 1000 for other types of rectifiers.

The Elkon EBH rectifier may be used in constructing new power units or may be used as a replacement rectifier in existing power units using a gaseous rectifier. In using it as a replacement rectifier no circuit changes are required; simply remove the present gaseous rectifier and place the EBH rectifier in the socket. The EBH rectifier cannot be used to replace rectifiers of the filament type without making changes in the wiring of the power unit.

The electrical characteristics of the Elkon EBH rectifier follow:

Use: In full-wave rectifier circuits of B-power units.

Base: Standard UX Base. The anodes are connected to the two filament prongs and the cathode to the plate prong.

Maximum permissible a. c. plate voltage per anode: 350 volts r. m. s.

Maximum d. c. output current: 125 milliamperes.

Maximum overall height: $5\frac{1}{8}$ inches.

Maximum overall diameter: $1\frac{3}{4}$ inches.

General: This rectifier is designed for use in the construction of B-power units to supply sets requiring plate voltages not in excess of about 180 volts. The prongs on the tube's base are so wired that this rectifier may be used as a replacement rectifier in all types of B-power units originally designed to use a gaseous-type rectifier. The Elkon Rectifier type EBH has similar characteristics to the type EBH except that the base is arranged to replace 280-type filament rectifiers in power units.



FIG. 2

How the rectifier compares in size with a screen-grid tube

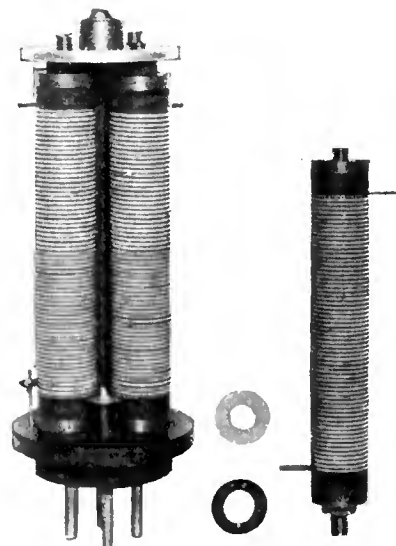

FIG. 3

Picture shows mechanical construction of the new metallic rectifier

Radio Broadcast's Service Data Sheets

The A. C.-66 Dayton Receiver



MODEL A.C.-66

THIS data sheet is devoted to a discussion of a receiver that utilizes the screen-grid tube as an r. f. amplifier. There are three r. f. stages in the set, the a. c. screen-grid tube being used in the first stage and 226-type tubes in the second and third r. f. stages. The detector circuit uses a 227-type tube, the first audio stage uses a 226-type tube and the power stage employs a 250-type tube. This receiver can be considered unique in that it is one of exceedingly few manufactured receivers that utilizes the screen-grid tube in the r. f. circuit and a 250-type tube in the output circuit.

TECHNICAL DISCUSSION

1. Tuning System

The four tuning condensers are ganged to a single control. Across the first tuning condenser is placed a midget variable condenser so that this circuit may be tuned to exact resonance. An antenna of ordinary length is connected directly to antenna terminal No. 1; a long antenna is connected to terminal No. 2 so that the signals are compelled to pass through a small fixed condenser, C_1 , which has a capacity of 0.00025 mfd. No neutralizing or stabilizing devices are necessary in conjunction with the 222-type tube. To suppress oscillations in the 226 circuits 900-ohm fixed resistors are connected in series with the grid of these two tubes.

2. Detector and Audio System

In the grid circuit of the detector is placed a 2-megohm grid leak and a 0.00025-mfd. grid condenser. The detector is a 227-type tube and the output of the detector is bypassed to ground with a 0.001-mfd. fixed condenser, C_2 . The audio amplifier contains two transformer-coupled stages. A 0.0025-mfd. fixed condenser is connected across the secondary of the first audio transformer to improve the high-frequency response. The 250-type output tube feeds into a choke-condenser combination located in the power unit.

3. Volume Control

The volume control in this receiver consists of a 100,000-ohm resistor, R_1 , connected across the secondary of the first tuned circuit. By adjusting this control it is possible to regulate the amount of energy fed into the r. f. amplifier. In this way the possibility of overloading in any of the tube circuits is prevented.

4. Filament Circuits

Filament current for the various tubes in the receiver is obtained from several windings on the power-supply transformer located in the power unit. The 222-type a. c. screen-grid tube obtains its current from a 2.5-volt winding, and 2.5 volts for the detector tube filament is obtained from a winding on a separate filament transformer. The r. f. tubes and the first audio tubes are supplied from a 1.5-volt winding and the 250-type power tube from a 7.5-volt winding. The 1.5-volt winding, is shunted in the receiver by a 20-ohm potentiometer, R_2 , with two 0.5-mfd. by-pass condensers connected across it, their center point being connected to the 125-volt lead from the power-supply unit. A 65-ohm center-tapped resistor, R_7 , is connected across the filament circuit of the 250-type power tube. The 20-ohm potentiometer is adjusted at the factory to the point of minimum hum in the loud speaker.

5. Plate Circuits

The screen grid of the 222-type tube and the plate circuit of the detector tube are supplied with 125 volts through a 35,000-ohm fixed resistor, R_3 , which serves to reduce the potential to approximately 45 volts. The plate circuit of the first audio tube is supplied with 125 volts through a 10,000-ohm fixed resistor, R_4 , which serves to reduce the potential to about 100 volts at the plate of the tube. The plates of the 226-type r. f. tubes and the plate of the screen-grid tube are all supplied with 125 volts. The 250-type tube is supplied with 350 volts from the power unit.

6. Grid Circuit

The grid bias on the grid of the screen-grid tube is 1.4 volts, obtained by connecting a 900-ohm resistor, R_5 , in series with the plate circuit of this tube and then utilizing the drop in voltage across it for grid bias. The 900-ohm resistor, R_5 , supplies 9 volts of grid bias to the 226-type r. f. tubes and the first audio tube. There is no bias on the detector tube. A 1500-ohm C-bias resistor in the power unit supplies 63 volts to the grid of the 250-type power tube.

7. The Power Supply

The power supply, not shown in the circuit diagram below, is placed in the cabinet with the radio receiver. The power unit is of conventional design, supplying all the d. c. and a. c. voltages required for the operation of the set. A 281-type tube is used as the rectifier.

The following data was supplied by Mr. R. S. Copp, Chief Engineer of the A-C Dayton Company:

"The a. c. screen-grid tube is rather new to the public and has only been available to manufacturers a comparatively short time, and, therefore, there is not a great deal of data available as yet. Our Engineering Department has been giving quite a bit of time in the laboratory on this new tube and we have found out a few things which might be of interest to the readers of RADIO BROADCAST.

"The a. c. screen-grid tube receiver, known as Model AC-66, uses one of these tubes in the first radio-frequency circuit only. It is placed in the first r. f. circuit in order to gain sensitivity, especially on inefficient antennas. This tube is then followed by two tuned stages of radio-frequency amplification, using the 226-type a. c. tube. The 227-type tube is used as detector, the 226-type tube as first audio and then for the last stage, we are

using the new 250-type super-power amplifier in order to give the best of tone quality with the increased volume obtained.

"We are using r. f. transformer coupling on the screen-grid tube with a ratio of one to three. This system is employed in preference to impedance coupling in order to obtain a good degree of selectivity, and yet not destroy the sensitivity which this tube has.

"Inasmuch as this new tube is for a. c. operation we obtain our C bias through a 900-ohm resistor in the plate-supply lead which is in series with the cathode and ground. This gives approximately 1.4-volt bias on the grid of the tube, with 125 volts of plate potential with 45 volts applied to the screen-grid element.

"The heater element of the a. c. screen-grid tube is the same as the one used in the 227-type tube, and the same methods are used as in the 227 heater circuit. The center tap of the heater circuit is grounded and is not connected to cathode as shown in some circuits. By grounding center-tap connection of heater winding the heater becomes 1.4 volts negative with regard to cathode which is necessary in order to obtain maximum efficiency.

"Our experiments on screen-grid tubes have shown us that this tube is very efficient. In fact, so much so in some cases as to prohibit the use of more than one of the tubes in a tuned r. f. set, without decreasing selectivity to an undesirable degree. Then again if several of these tubes are used and coupled properly to obtain the highest order of amplification, the sensitivity becomes so great as to increase background noises which in the end does not give satisfactory results, unless the volume is reduced and then the efficiency is back again to that of one tube, in the first r. f., followed by regular tubes as r. f. amplifiers.

"The shielding of a screen-grid amplifier is very important, otherwise, inter-coupling of circuits will develop and cause uncontrollable oscillation. Where only one screen-grid tube is used, it is not necessary to employ extreme shielding, as is the case where two or more are used in a receiver.

"With our form of construction and circuit design, we find a gain of approximately twenty in the first stage as compared to approximately eight in the second and third stages of the r. f. circuit, therefore, our gain up to the detector tube is in the order of about 1300, whereas the gain on a straight 226-type set-up of three stages is about 500. This we believe is a sufficient increase over a 226-type set-up, presenting a compromise of amplification and selectivity.

"If three stages of screen-grid amplification were used, a gain of twenty per stage could be maintained; the result would be 8000. However, this gain is entirely theoretical and would be decreased by several thousand in actual practice. Granting that we could count on a gain of 6000, what would our chances be in using it all? Atmospheric static and electrical disturbances in the average community are such to-day that this enormous amplification would cause a noise level in the volume of a roar and in order to reduce this roar, the volume control would have to be retarded greatly, so we would be only bringing up something we could not use and there is no object in this."

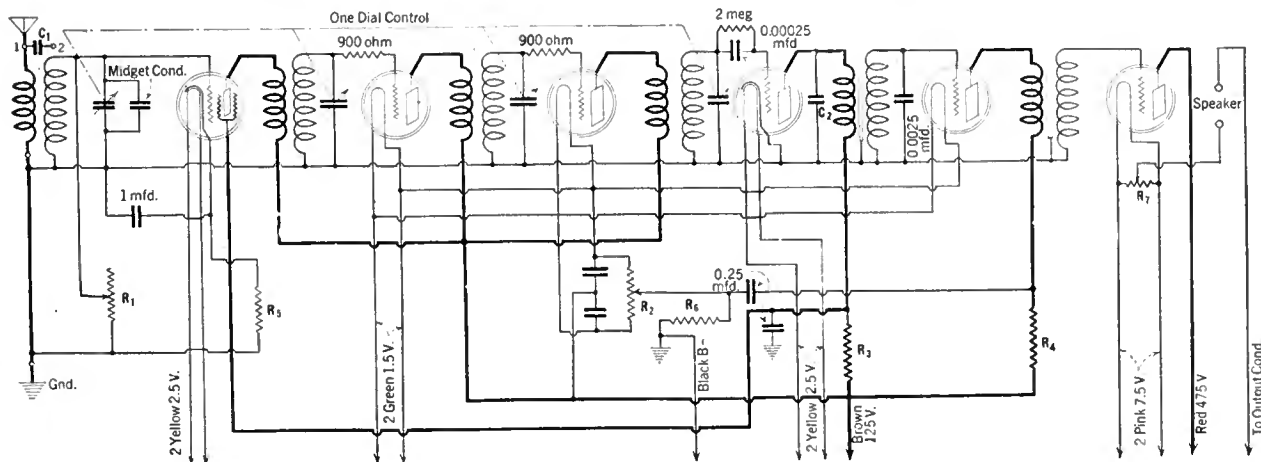

THE RECEIVER CIRCUIT

No. 14.

December, 1928.

Radio Broadcast's Service Data Sheets

The Fada 50, 70, 71, 72 A. C. Electric Radio Receivers

THE Fada receivers, models 50, 70, 71 and 72, all use the same chassis so that in operation and in technical characteristics they are similar. The model 50 is a table model, the 70 is housed in a low-boy console, the 71 in a high-boy console, and the 72 is contained in a console which also contains a phonograph turntable and pick-up unit. The receivers are of the single-control type, the station finder being calibrated in wavelengths and also in degrees. The sets may be operated on either a loop or antenna. The models 70, 71, and 72 are equipped with a new Fada model-14 dynamic speaker.

TECHNICAL DISCUSSION

1. Tuning System

The tuning system used in these receivers comprises four r.f. transformers and tuning condensers and include of L_1C_1 , L_2C_2 , L_3C_3 and L_4C_4 . The four tuning condensers are ganged to one control and are operated by a single drum dial. Between the first and second r.f. tubes is placed a special untuned radio-frequency transformer designed with a gain-frequency characteristic essentially opposite to that of an ordinary tuned radio-frequency transformer; the result of using such a transformer is that the gain-frequency characteristic of the entire receiver is made much more uniform than it would otherwise be. All of the stages are neutralized by the Hazeltine method. The neutralizing condensers are C_5 , C_6 , C_7 and C_8 . Each radio-frequency transformer is enclosed in a shield in order to prevent interstage coupling. The tuning condensers, C_3 , C_4 and C_5 , are shunted by small midge condensers which are adjusted at the factory to bring each stage into exact resonance.

2. Detector and Audio System

A grid-leak-condenser-type detector is used, C_9 being the grid condenser and R_1 the grid leak. The output of the detector is bypassed to ground by the fixed condenser C_{10} , and, in order to keep the radio-frequency currents out of the audio system, the r.f. choke coil, L_5 , is placed in the detector plate lead. The audio amplifier is a two-stage transformer-coupled affair with a phonograph jack placed across the primary terminals of the first audio transformer. An interesting point about the audio amplifier is that the d.c. plate current of the first audio tube is kept out of the primary of the input push-pull transformer, T_2 , by means of the fixed condenser C_9 and the audio-frequency choke coil, L_6 . The removal of the direct current from the transformer winding eliminates the possi-



MODEL 72

bility of saturation in the core which would lower the inductance and cause a loss in amplification at low frequencies.

3. Volume Control

The volume control, R_2 , is a variable high resistor connected across the secondary of the untuned radio-frequency transformer. In this position it serves to control the amount of energy fed into the remainder of the r.f. amplifier and detector system.

4. Filament Circuits

Since 227-type tubes are used in all the sockets of this receiver with the exception of the power stage only two filament windings are necessary on the power transformer. One of these windings supplies approximately 2.5 volts to the heaters of all the 227-type tubes and the other winding supplies current to the power tubes in the push-pull amplifier. To prevent the r.f. currents in the amplifier circuits from circulating around the various cir-

cuits, choke coils, L_7 , L_8 , L_9 , L_{10} , are placed in the cathode leads to each of the four r.f. tubes.

5. Plate Circuits

Filters are used in the plate circuits of all the r.f. tubes so that the r.f. currents are compelled to return directly to the cathodes of the 227-type tubes. If the filter systems were not used these currents would pass into the power system where common coupling would result. The filter systems in the r.f. plate circuits consist in each case of R_3 and C_{11} . The filter system in the plate circuit of the detector tube consists simply of C_{12} .

6. Grid Circuits

C bias for the various grid circuits is obtained by connecting fixed resistors in series with the cathode leads in the case of the 227-type tubes and in series with the center-tap connection of the filament-transformer winding in the case of the power tube. For bias on all the r.f. tubes a common resistor, R_4 , is used. It is bypassed by C_{15} . Bias for the first audio tube is obtained from R_5 and bias for the power tubes is obtained from the resistor, R_6 , located in the power-supply device.

7. The Power Supply

Two power-supply units are available for use with this series of receivers. The type E-420 is for use with 210-type power tubes and the type E-180 is for use with 171A-type power tubes. The latter power unit is illustrated in the circuit below. This power unit consists essentially of the power transformer, T_1 , which supplies plate and filament voltages for operation of a 280-type full-wave rectifier tube and filament voltages for the receiver. The output of the full-wave rectifier leads into the filter system, consisting of the two filter choke coils, L_{11} and L_{12} , and the filter condensers C_{13} . The condenser, C_{14} , connects from side of the 110-volt line to the ground circuit and this condenser serves to bypass to ground any line noises which might otherwise be audible in the output of the receiver. Plate voltage for the power tube is obtained at the junction between the two filter choke coils, and plate voltages for all the other tubes in the receiver are obtained by connecting suitable resistors across the output of the filter system. The primary of the power transformer is arranged with two taps, one for use with line potentials of 110 to 130 volts and the other for use on line potentials of 90 to 110 volts. Power to the entire receiver is controlled by the switch, SW. The power units E-420 and E-180 are both available in two models so that the receiver may be operated from power lines with a frequency of 50-60 cycles or 25-49 cycles.

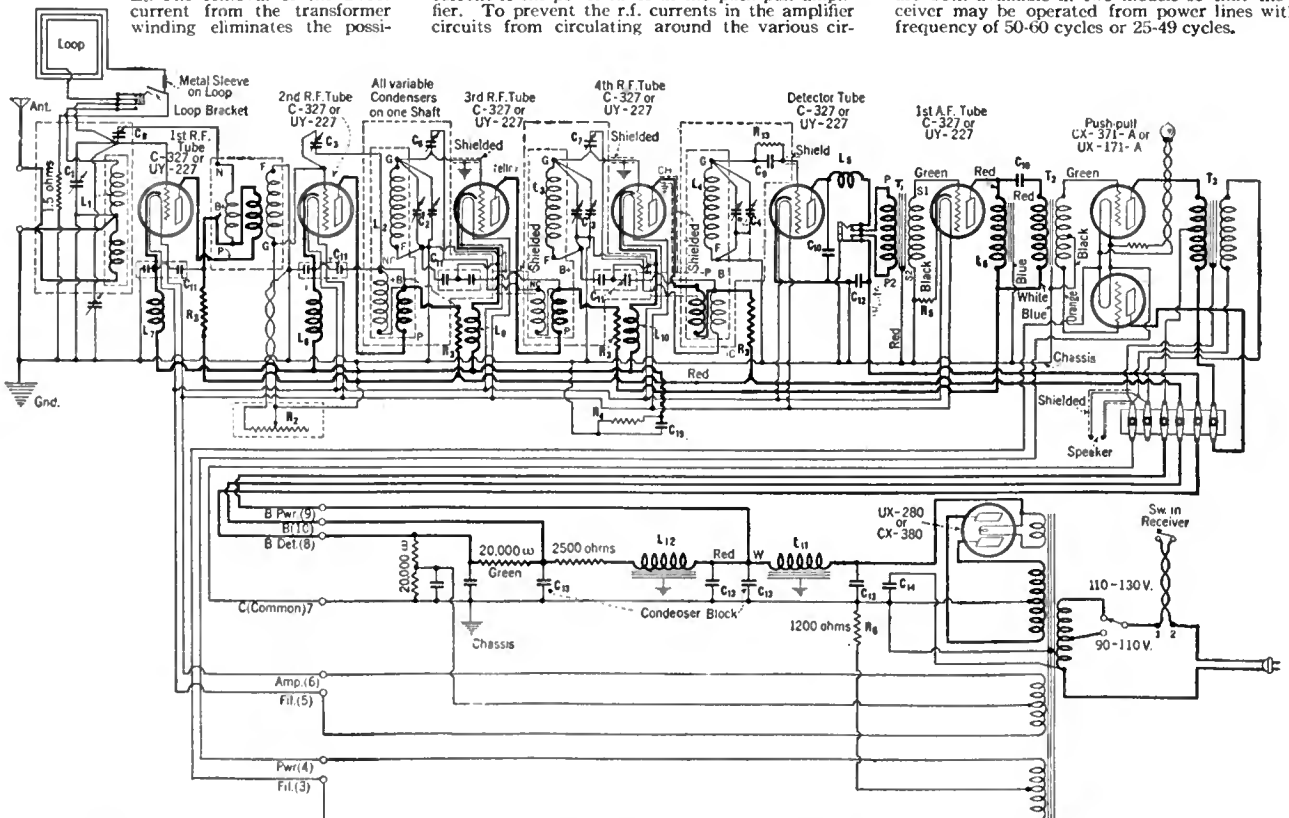

THE RECEIVER AND POWER CIRCUITS

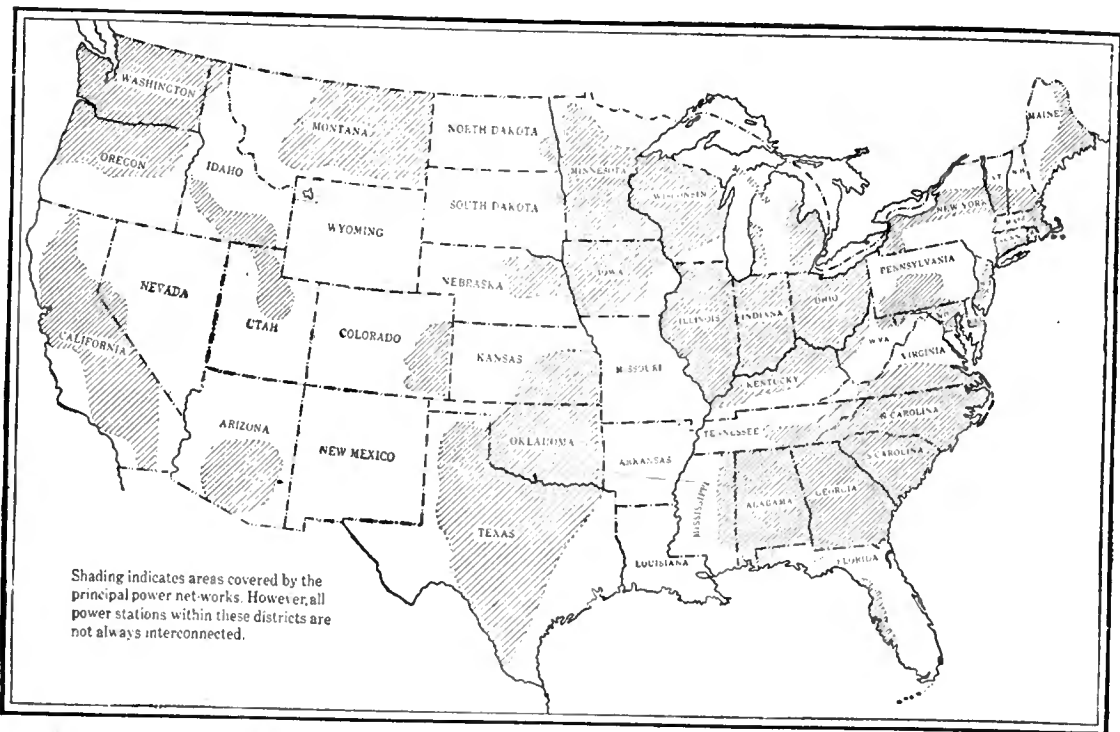

POWER NETWORKS DO NOT PROVIDE A SOLUTION TO THE PROBLEM OF SYNCHRONIZING TELEVISION RECEIVERS

The rapidity of development makes it practically impossible to obtain an accurate up-to-date map showing the power networks in the United States. Nevertheless, the shaded districts in the above illustration give some idea of what has been accomplished in this field. In addition many of the networks shown above may be connected if necessary.

Problems in Synchronizing Television Receiving Discs

By **BOYD PHELPS**

THE development of a system for keeping the scanning disc of a television receiver in exact synchronism with that of the transmitting disc is one of the biggest problems in radio at the present time. The simplest method would be to have the disc at the transmitter on the same shaft with the similar disc at the receiver. For a review of the principles of television, this simplified arrangement will be considered.

In diagram A of Fig. 1 the subject, A, at the left is being viewed by the electrical eye, C, through the holes in the rotating scanning disc, E. The varying electrical impulses in C, produced by different intensities of light reflected from light and dark parts of the face of A, are amplified by a common vacuum-tube amplifier and cause the brilliancy of the flat plate in the neon tube, D, to vary in step. An observer, B, looks through spirally arranged holes in disc F at this plate and, although he actually sees it through only one hole at a time, the rapid rotation of the disc gives him the impression that image, A, is on the flat plate in D. What B sees is shown in diagram B of Fig. 1, the dotted line representing the margins of the scene. Each hole in the disc passes across the scene and traces the light-intensity variations on the plate below the path of the previous hole until the last hole in the spiral comes around when the process is repeated.

It will be evident what a mess would be made of the picture if the receiving disc should slip around on the shaft only half a picture width, or if it was half a turn out of phase with the transmitter disc. But such a difficulty would be tame as compared to cutting the shaft between the two discs and running the discs with separate motors at different speeds! A rain or black and white dots or streaks with no trace of a picture

would be the result. With these remarks as an introduction the necessity for precision in the maintenance of exact speed of the receiving disc in television may be more apparent.

SYNCHRONOUS MOTORS

FOR distance transmission where a shaft connecting transmitter and receiver is impractical, the first method of synchronizing that seems obvious is to use synchronous motors operating on the same alternating-current supply. This works fairly well under some conditions, but we shall speak more of this later. An ordinary 1760 r. p. m. squirrel-cage induction motor will run synchronous at 1800 r.p.m. on 60 cycles if four slots are cut in the rotor, and similarly, motors can be made to run 3600, 1200, 900, etc. Fifteen complete pictures per second means 900 r. p. m. of the scanning disc and is about the minimum speed permissible without flicker. This speed is used at present by C. F. Jenkins at his station 3xK in Washington, D. C., on 46.72 meters (see Table 11). Twenty pictures per second means 1200 r. p. m. of the scanning disc and is the speed used for receiving the wgv pictures on 380 meters from Schenectady, N. Y.

SYNCHRONIZATION is one of the major problems in the accomplishment of television. Although in experimental television, manual control may be used satisfactorily, it is absolutely essential, if any sort of practical television is to be achieved finally, that some method of synchronization be evolved that will hold the received image exactly stationary on the screen of the television receiver. At one time or another many of us probably have thought over the possibilities of synchronizing the television receiver with the transmitter by the use of synchronous motors operated from the power lines of the local power company. A discussion of this method of synchronization is the subject of this article.

The author, Mr. Phelps, after many heated arguments with radio enthusiasts who felt that this method would work satisfactorily, decided that the only way to settle the argument was actually to get the "dope" and the ingenious method which he used to secure the data certainly makes interesting reading.

—THE EDITOR.

A frequency higher than 60 gives a more accurate lining up of the edges of the picture, so in the Bell Telephone demonstra-

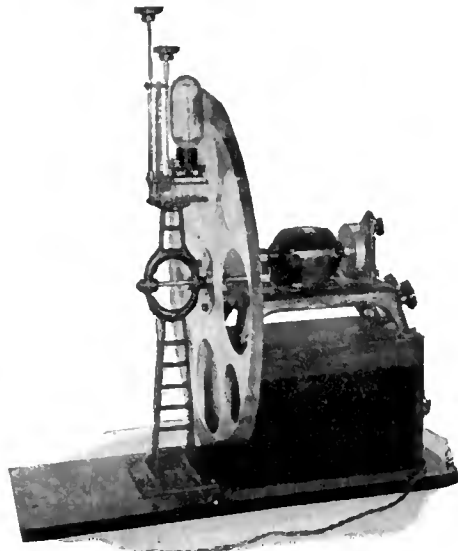

A variable-speed motor with a highly developed speed control is used in this televisior

tions a 2000-cycle current was generated by the motor turning the transmitter disc. This current was carried by a pair of wires, or a separate radio-wave channel, to the receiver where it was amplified and fed into a 2000-cycle synchronous motor. This motor was aided in driving the receiving disc by a larger motor adjusted quite closely to the right speed. Rumors have it that the Baird system scrambles a synchronizing signal in with the picture frequencies and thus needs only a single pair of wires or wave band for the whole television operation. If so, and it is simple, it is a great step in the right direction.

Then we have many semi-successful speed regulators for variable-speed motors. Some are highly developed mechanical governors similar to the one shown in the picture. It is an interesting diversion to put a slip of paper under the edge of a phonograph record on the turntable and try adjusting the speed to, say, 75 revolutions per minute. After several minutes of timing and re-adjustment notice if the slip of paper crosses the starting position at the end of every minute. Electrical equivalents often include a resistor that may be short circuited periodically with a button or key manipulated by the operator who must pay close attention to the direction the picture is slipping, bring it back quickly, and not overdo it. The exact speed adjustment may be found finally with any of these devices, but at that moment the disc may be part of a turn around from where it should be, so exact synchronism in every respect is not easy. It is quite a ways from throwing a switch and sitting in the big arm chair for an evening's entertainment as we now do with audible programs (or until some advertising program gets so nauseating we tune in another station)

So far it might appear that a synchronous motor connected to the home-lighting current is the final answer, as 60 cycles is the standard frequency supplied about 98 per cent., of the homes in this country having public electric service. Indeed, many believe this is the only satisfactory answer, and in most any radio store one can get into heated argument on either side of the question. The only tangible evidence seems to be that

a brand of clock, known as a "Telechron," which has a miniature synchronous motor geared down to the hands, seem reasonably accurate when operated on a 60-cycle circuit. The arguments then proceed along lines of how much deviation from 60,000 cycles is permissible for television, and if the clocks gain or lose a few seconds per day how many times in so many minutes will the pictures be null and void or worse. Also, if the error accumulating during the 24 hours of the day is corrected in the space of an hour by a worse error in the opposite direction what will be the effect? The writer, being of an experimental turn of mind, and thoroughly fed up on such arguments which get nowhere, decided to find out for himself how the various so-called 60-cycle currents in different parts of the country compare, which data forms the "meat" of this article. If anyone else knew the answer, based on measurements instead of hearsay or guess, he has certainly kept it a close secret.

A few oscillographs costing a few thousand dollars connected to a few leased long-distance telephone lines and an army of engineers putting local lighting current on the end of these lines suggested itself as the first solution. It never got further than a suggestion, however, as every radio amateur has a reputation to uphold, namely, being able to get any result desired from the stuff in his boxes of junk. (That wasn't the only reason, but it may get by.)

Now it so happens that when a neon bulb (costing 55c) held in the hand is moved parallel with an antenna lead of an amateur transmitter it lights bright and dim in spots if a poor filter is used in the transmitter plate-supply system. If no filter is used at all there are spaces between the bright spots that are dark, especially if a single oscillator tube is used in a transmitter operating on one half of the a.c. cycle. This lamp acts the same way if connected through a transformer to the output of several stages of audio-frequency

amplification after an ordinary short-wave tuner has been adjusted to similar signals from other amateur stations. Now it was only necessary to compare these flashes produced by the distant station with those caused by the local lighting current to measure their difference in frequency. Here at last was found one desirable feature of the class of transmitter which is most cursed by broadcast listeners in its immediate vicinity!

The first measurements were made by passing enough of the local house current through the neon lamp to light it to about half brilliancy or about the same intensity as the signal which was passed through the same lamp. When the incoming signal was in step with the local power the

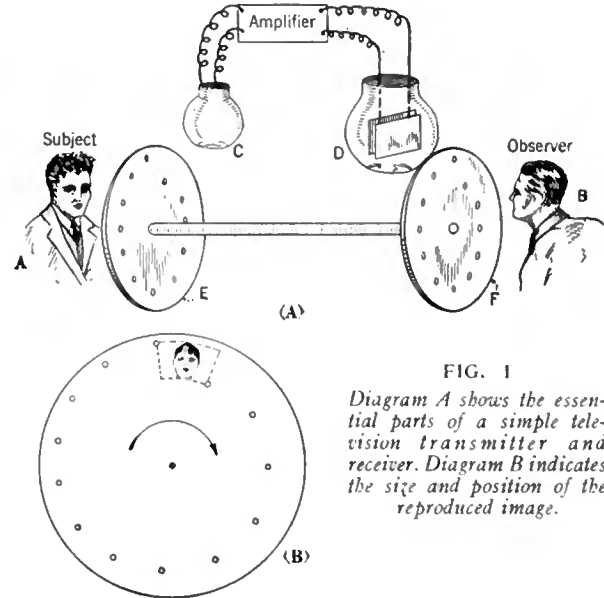

FIG. 1

Diagram A shows the essential parts of a simple television transmitter and receiver. Diagram B indicates the size and position of the reproduced image.

lamp became bright, and when it slipped behind a half cycle, or gained a half cycle, so it was 180 degrees out of phase the lamp went out or became dim. This would have been entirely satisfactory except for four things: It was hard to time or count the pulsations when the station was keying; it was slow and discouraging trying to call and instruct the right amateur stations

to hold their keys down for a few minutes; there was no way of knowing which frequency was the faster, and atmospheric fading, quite rapid at this time of the year, made the results very confusing.

Experimental research at this point gave way to plain "monkeying." Engineers seldom use this undignified expression but their "cut and try" is much the same. An old quarter horse power induction motor with a white cardboard disc on the shaft and a black diameter line inked across the disc was illuminated with the neon lamp connected on the local lighting current. With this arrangement it was noticed that the motor ran so near synchronous (1800 r. p. m.) that the black line looked like a four-spoke wheel slowly turning backward (like old time movies of buggy carriages). A hack saw and cold chisel on the rotor soon made a synchronous motor and the "spokes" thereafter stood still. But when the neon lamp was lighted by the amplified signals of distant "raw-a.c." amateur stations the spokes revolved, sometimes fast, sometimes slow, sometimes backward, and sometimes forward, and therein hangs this tale.

Table I. Comparisons of Lighting Frequencies

*Time	Call	Location	Sec. per Rev.	Direction	Frequency
8:21	3BR	Toronto, Ont.	2.2	Same	59.546
8:22	3ALS	Richmond, Va.	5.2	Same	59.615
8:27	3ALS	Richmond, Va.	17.0	Same	59.882
8:37		Tampa, Fla.	.75	Against	62.666
8:39	3AJD	Catonsville, Md.	1.0	Same	58.000
8:42	9BEU	St. John's Sta., Mo.	?	Same	59.333
8:45	8DVM	Not Listed	?	**	60.000
8:49	WIZ	New Brunswick, N. J.	24.7	Same	59.927
9:00	WIZ	New Brunswick, N. J.	23.7	Against	60.084
9:02	2BGZ	Jamaica, L. I., N. Y.	?	**	60.000
9:04	3APQ	Quakertown, Pa.	5	Against	60.400
9:06	2BKH	Bloomfield, N. J.	30	Same	59.933
9:09	4AAR	Elkin, N. C.	5.3	Against	60.378
9:11	2WI	Westfield, N. J.	?	**	60.000
9:13	CU	(Unknown)	5.7	Against	60.351
9:14	nu	(Unknown)	6.5	Against	60.308
9:15	3AVL	Not listed	7.3	Against	60.274
9:16	3AVL	Not listed	5	Against	60.400
9:17	3AVL	Not listed	6.2	Against	60.323
9:19	2WI	Westfield, N. J.	?	**	60.000
9:22	4AHO	Not listed	240.	Against	60.008
9:25	WYE	Mt. Clemens, Mich.	120.	Same ***	59.984
9:30	9EWQ	Richmond, Ind.	7	Against ***	60.286
9:32	3CGF	Phoebus, Va.	17.2	Same	59.884
9:35	8DBG	East Liberty, Pa.	?	**	60.000
9:40	2BLX	White Plains, N. Y.	?	**	60.000
9:43	1CTP	West Haven, Conn.	20	Against	60.100
9:46	8BFR	Jeanette, Pa.	20.4	Against	60.098
9:50	3APQ	Quakertown, Pa.	10	Against	60.200
9:53	1CRS	Not listed	28	Same	59.929
9:57	4AB	Raleigh, N. C.	5.8	Against	60.385
9:59	8DNJ	Bay City, Mich.	?	**	60.000
10:00	9ERH	Chicago, Ill.	21	Against	60.096
10:05	9EJO	Geneva, Ill.	30	Same	59.933
9 A.M.	WGT	San Juan, Porto Rico	1	Against	62.000

*Time P. M. (Eastern Daylight Saving) unless indicated otherwise.
 **Exact synchronism or very close to this.
 ***Peculiar modulation producing additional "spokes."

Table II. New U. S. Television Licenses

Call	Location	Power in watts	Wave Band* in meters
4XA	White Haven, Tenn.	5,000	125-120
2XBV	New York City	5,000	66.67-65.22
6XC	Los Angeles, Calif.	15,000	
2XBS	New York City	5,000	65.22-63.83
8XI	East Pittsburgh, Pa.	20,000	63.83-62.5
1XAY	Lexington, Mass.	500	62.5-61.22
2XBU	Beacon, N. Y.	100	
3XK	Washington, D. C.	5,000	61.22-60.00
8XI	East Pittsburgh, Pa.	20,000	19.86-19.73
2XBW	Bound Brook, N. J.	5,000	

* Each band 100 kc. wide

The motor disc and neon lamp were put in a darkened box. A double-pole double-throw switch changed the lamp from amplifier to local a.c. to check motor synchronism, but it was always found in step. A stop watch timed the number of seconds taken by the image of a spoked wheel to make one complete revolution. There being four poles to the 1800 r.p. m. motor this meant a gain or loss of two cycles per revolution of the wheel image. If the "wheel" moved in a direction opposite to that of the disc the received frequency was leading the local frequency. While it is not certain the local frequency was exactly 60,000 cycles during this test it generally is found to be very close to this, and synchronous clocks in the vicinity (Jamaica, Queens County, N. Y.) keep very good time. This is more or less confirmed by the fact that about as many of the frequencies measured were found higher as were lower. The observations listed in Table I were taken July 24, 1928, the time being Eastern Daylight-Saving time. The hours during which the tests were made represent possibly extreme power load fluctuations between sunset and evening darkness when lights were being switched on, but also this is the time when most people would be using their television receivers. Due to the quite uniform motion of the "wheel" it could be followed on code stations and none of the amateurs listed know that they participated in this test, it being unnecessary to get in communication with them on the local transmitter. Where the seconds required for a revolution of the "spoked wheel" are a few it means it was revolving fast and indicated a great deviation from the local standard frequency. A great number of seconds for one turn in either direction indicates close to but not quite synchronism. The stations with calls beginning with

the numeral "2" that are shown probably were operated from the same power network. Three distant stations had to be listed as being in exact synchronism because for the duration of the measurement, usually two minutes, no variation in their frequency could be noted. Such are probably rare coincidences and if measured for a quarter hour would probably show slow creeping of frequency. Two others came quite near this standard. Due to peculiarities of transmitter circuits, or filters producing frequencies that were multiples of 60 cycles, additional "spokes" were present for some stations, oftentimes eight, occasionally twelve or sixteen, but it was not very hard to time one revolution if the modulation was strong.

The method of collecting the data as explained above is so similar to what would happen in attempting television by synchronous motors on these power supplies that the answer can be read directly from the notes or data. A synchronous television motor running 900 r.p.m. would, however, take twice as long to get out of step as the figures under the column headed "Sec. per

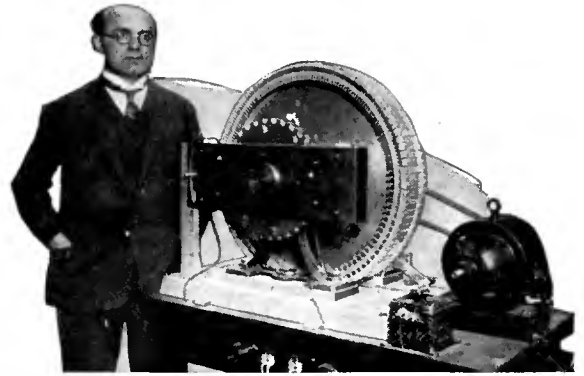

NEW TELEVISION PROJECTOR

This apparatus was exhibited at the German Radio Exposition in Berlin by Prof. Karolus of Leipzig

Rev." A better statement of the case would be to say that (except for local stations) there would be no picture practically all of the time, but that every so many seconds the picture would appear correct for a moment. This puts a different angle on the problem and a vote taken amongst television friends seems to indicate that if non-synchronism must be tolerated they would prefer having the picture come flitting in right every second or so rather than spreading out with long periods between correct pictures. In other words, almost exact synchronism would be more of a nuisance than a moderate variation, which is an unlooked for conclusion!

The data, even allowing a ten per cent. error in some of the readings, forces us to admit that synchronous motor operation from lines out of our own network is far from satisfactory and thus one more hope for simple synchronizing is shot to pieces. We now understand the hesitancy of the big radio companies in not placing complete televisions on the market immediately after the first public demonstrations. Television to-day is in about the same stage as the old chain-drive, stem-wind horseless carriages of not so long ago, but how many goggled drivers of those days now regret their early escapades when a driver had to be a mechanic? By the time this article is published television probably will have made several notable advances. A more interesting and fruitful field for individual experiment is difficult to find.

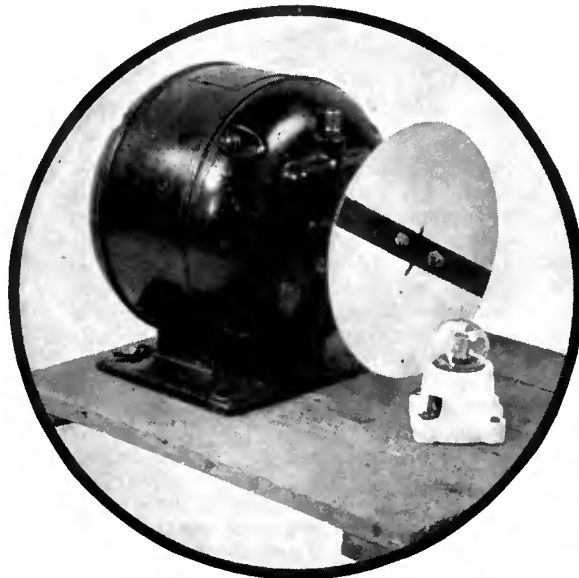

APPARATUS USED BY MR. PHELPS IN CHECKING POWER-LINE FREQUENCIES

Book Review

"A LABORATORY TREATISE ON B BATTERY ELIMINATOR DESIGN AND CONSTRUCTION." Published by Radio Treatise Company, New York City, 87 pages. Price—\$1.00.

THE text of this book is intended to set forth the essential principles of the design and operation of B-power units.

The book is divided into several major sections as follows: Power Transformers, Rectifiers, Condensers, Filter Chokes, Calculation of Resistances, C-Bias Voltages and Resistances, and General Considerations. The last page of the book contains an index. In the various chapters the functioning of the component parts of a B-power unit is considered.

Probably the major problem one confronts in the building of a B-power unit is the choice of the apparatus; that is, deciding what rating it should

have and what capacity. The author discusses these subjects quite fully, and indicates the sort of power transformers which should be used with different B units, the value of the chokes, filter condensers and resistors.

The dictionary being the only book in which one probably can't find an error, the typographical errors (of which there are quite a few) in this book may be excused. Technically the book seems to be sound, although some serious errors are to be found. For instance, on page 57 the author states that, in connection with a.c. voltages, "the average voltage is that value indicated on our a.c. voltmeter." Actually an a.c. voltmeter reads effective values. Average voltages are also confused with effective values in the statement that, "the peak voltage is equal to 1.4 times the average value."

The chapter on filter condensers, page 60,

states that if two condensers with similar ratings are connected in series, the total voltage across them may safely be twice the rated voltage. A diagram is given showing two condensers so connected. This is one instance where we cannot recommend that the author's suggestion be put into practice. When two condensers are connected in series across a source of d.c. potential, the division of voltage between the two condensers depends not at all on their respective capacity—it depends entirely on their resistance.

However, in spite of these points about which we differ with the author, we want to assure the reader that the book contains a potpourri of exceedingly helpful data. Its low cost puts it within the reach of all of us and it is certainly a worth-while addition to a library of elementary radio texts.

—H. E. R.

The "Chronophase" for A. C. Tubes

By BERT E. SMITH

Aero Products, Inc.

IN RECENT issues of RADIO BROADCAST, data have been published outlining the development of the new "Chronophase" system of radio-frequency amplification, and describing the construction of a screen-grid receiver using this circuit.

Some kit builders are not particularly anxious to use screen-grid tubes, because of their tendency to amplify microphonic noises and also due to the fact that their filaments are so delicate. Others feel that the storage battery is an unnecessary evil and are anxious to construct a receiver which can be plugged directly into an electric-light socket. For these fans another model of this receiver has been designed which makes use of alternating-current tubes throughout. In this article the a. c. model of the "Chronophase" receiver is described.

The construction of the a. c. model of the "Chronophase" receiver is in many details similar to that of the screen-grid model which was described in last month's issue. The assembly of the set is simple, and complete instructions are supplied with the kit of parts.

The circuit diagram, given in Fig. 1, shows that the leads to the last stage of audio amplification are independent of other parts of the set. Therefore, if the proper power supply is available, a 210- or 250-type tube may be used in this stage, simply by applying 7½ volts to the red and black terminals of the Yaxley cable connector and four- to five-hundred volts to the brown lead. In the event that a 250-type tube is used, a resistor capable of dissipating at least forty watts should be connected between the green lead of the cable connector plate and the B-minus wire. A resistor of 2000 ohms is approximately correct for all types of tubes.

No output device has been incorporated in this receiver since many of the loud-speakers, particularly of the dynamic type which are now very popular, are provided with transformers

for coupling the output of a power tube to the actuating windings of the speaker. Several methods of coupling the speaker to the final tube are given in Fig. 2.

Many owners of radio sets have phonographs of a more or less obsolete type. In this connection it is interesting to note that a first-class audio-

The changes required in the receiver for the reproduction of phonograph music are exceedingly simple. A regular phone jack may be inserted in the set or tip jacks may be used. If tip jacks are used, attach one tip jack to transformer post labeled P and the other to transformer post labeled B as shown at the point marked X in Fig. 1. If this last method is used, the detector tube must be removed from the socket when the phonograph pick-up unit is used.

The following are the parts included in the "Chronophase" A. C. Five Receiver kit:

C₁, C₂, C₃ One Acro triple-gang condenser, .00035-mfd., type AE-2155;

C₄ One Aero Midget condenser; C₆, C₆, C₇ Three Aerovox moulded mica condensers, .001-mfd.;

C₈ One Aerovox moulded mica condenser, .00025-mfd.;

L₁, L₂, L₃ 1 Aero coil kit, type U-203;

L₄, L₅ Two Aero r.f. choke coils, type C-60;

R₁ One Special Centralab resistor, AE-250;

R₂ One grid leak, 3-meg;

R₃ One Yaxley resistor, 2000-ohm;

R₄ One Yaxley resistor, 600-ohm;

T₁, T₂ Two Aero audio transformers, type AE-770;

Y One Yaxley cable connector and plug, type 660;

One Aero A. C. "Chronophase" foundation unit, including No. 400 cabinet, escutcheon plate, base unit with sockets mounted, wire, solder, and all other parts necessary for mounting and completing set, such as machine screws, bushings, etc.

One National dial, type "E";

Three Kurz-Kasch special knobs;

Three Eby "Junior" binding posts;

One pair Yaxley tip-jacks, type 422.

Total cost of kit as supplied by Aero Products Company, \$74.50.

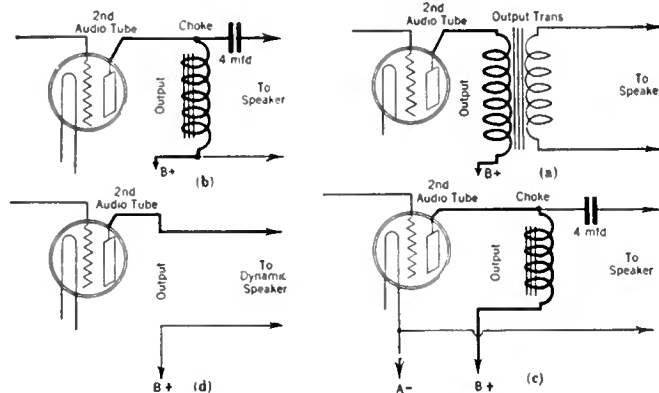

FIG. 2. OUTPUT CIRCUITS

frequency amplifier, such as is used in "Chronophase," will, with a good loud-speaker, amplify phonograph music equally as well as the finest and most expensive up-to-date phonographs. Therefore, many users may gain a great deal of pleasure by purchasing a phonograph pick-up unit and attaching it to the audio amplifier of their A. C. "Chronophase" receiver.

The audio-frequency amplifier used in the "Chronophase" is ideally suited for use with phonograph pick-up units, particularly in the a. c. models where a 210- or 250-type tube may be used in the last stage. The Aero transformers are designed so that they have a very flat amplification characteristic up to above seven-thousand cycles and above that point almost no amplification whatever is obtained, thus reducing the "needle-scratch".

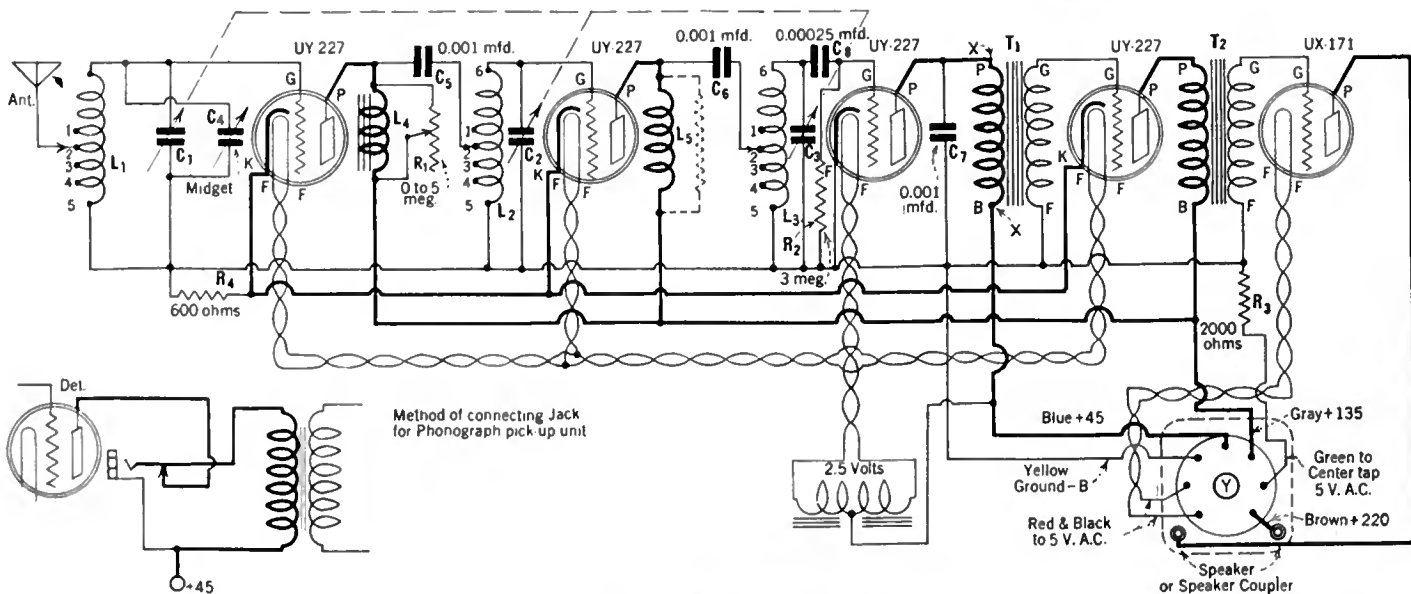

FIG. 1. SCHEMATIC DIAGRAM

New Apparatus and Their Applications

How to Build a B-Power Unit with Recently Announced Parts

ARE you operating your receiver in the most economical manner possible? If a power tube, such as the 171A, is used in the last stage it is advisable to use a socket-power unit to supply the plate power. A B-power unit designed to supply the various plate voltages required for the operation of any standard receiver may be constructed easily. The apparatus required are: a power transformer designed to supply plate and filament voltages for the operation of the rectifier tube and filament voltage for the operation of the power tube if this latter is to be operated from alternating current, filter choke coils and filter condensers to change the pulsating current from the rectifier to a steady d.c. required by the plate circuits of the various tubes, and a bank of resistances and by-pass condensers which will enable you to obtain the intermediate values of voltages required for the operation of the amplifier and detector tubes in the receiver. The illustration on this page shows how such a unit may be constructed easily and inexpensively from a group of standard parts which recently have been placed on the market.

This power unit supplies 180 volts for the plate of a 171A-type tube and also delivers the negative 40-volt C-bias potential which this tube requires. Intermediate potentials of 135, 90, 67 and 45 volts are also available. These latter voltages are variable to some extent—the voltage from the 135-volt tap may be adjusted to any desired value from about 120 volts to 180 volts, the 90-volt tap is adjustable from 80 to 120, the 67-volt tap may be varied from 60 to 80 volts and the 45-volt tap is adjustable from 0 to 60. The voltage from the various taps is adjusted by rotating the arms on the Frost 2000-ohm potentiometers; this arrangement making it possible to use this power unit with any receiver, for it is possible to adjust easily the different output potentials to give most efficient operation of the radio receiver.

The power transformer at the left is a Dongan type 5509 containing three secondary windings—two 5-volts windings and one high-voltage winding, supplying 300 volts either side of the center-tap connection. The Dongan choke coil, type 7542, contains two filter chokes in a single case. The filter condensers are three 2-mfd. 400-volt Frost type 1305. Each of the Frost potentiometers connected across the output have a value of 2000 ohms. The long resistance located at the lower left-hand corner has a value of 2000 ohms and it supplies the 40-volt C bias required for the 171A-type power tube.

To assemble this power unit the apparatus should first be mounted on the baseboard as shown in the picture. The leads from the power transformer should then be connected to the rectifier tube socket. As indicated in the picture, the two red leads from the high-voltage winding on the transformer are connected to the grid and plate terminals of the socket; the two filament posts of the socket are connected to the two black leads from one of the filament windings of the transformer.

The colors of these and the other wires leading from the power transformer and the filter choke coils are indicated in the picture and if it is followed carefully no difficulty should be experienced in constructing the unit. The parts required for the construction of this unit are listed below:

T—One Dongan power transformer, type 5509;

Important Announcement

THIS month an important change is made in the method of treating new apparatus in these pages. All of the various pieces of apparatus available for description were suited for use in B power-supply devices. Therefore, in order to provide a concrete example of an application for each of these units, it was decided to incorporate them in a B-power unit. Not only does this unit illustrate a use for the various pieces of apparatus under discussion, but it also provides an ideal design for the set-builder to follow. The power unit is of up-to-the-minute design, it will provide B potentials to any standard receiver and A, B and C potentials to a 171A-type power tube, it is easy to build, and the cost of the parts is \$38.40. In future issues, if the occasion presents itself, this method of presentation will be applied to other types of apparatus.

—THE EDITOR

- L₁—One Dongan filter choke coil, type 7542;
- C₁, C₂, C₃—Three Frost 1-mfd. 200-volt by-pass condensers, Type 1104;
- R₁, R₂, R₃, R₄—Four Frost 2000-ohm potentiometers;
- R₅—One Frost 2000-ohm fixed resistor;
- 1 Frost Socket.

The various Frost resistors used in this unit are part of the "Universal Resistance Kit" which this company manufactures.

New Power Transformers and Filter Choke Coil

X77

Device: Power Transformers and Filter Chokes. Various types, are available to meet the requirements of all different types of power units.

Manufacturer: Dongan Electric Manufacturing Company.

Application: The B-power unit described on this page illustrates a typical application of these filter chokes and transformers in the construction of a power unit. Complete circuit diagram and constructional information on various types of power units may be obtained by writing the manufacturer.

New Power Unit Parts

X78

Device: FILTER CONDENSERS and UNIVERSAL RESISTANCE KIT, TYPE NO. 300. These parts are for use in construction of power units.

DATA ON UNIVERSAL RESISTANCE KIT

This kit consists of three 2000-ohm fixed resistors each of the A series, wound on flexible bakelite strips, one inch wide and five and one-half inches long; four 2000-ohm heavy-duty wire-wound potentiometers, and one 1500-ohm A series fixed resistor. This kit may be used in all present types of power amplifiers, including those using 210- or 250-type tubes in a push-pull circuit. The total heat dissipation of the kit is 72 watts. Price: \$9.00.

DATA ON FILTER AND BY-PASS CONDENSERS

Individual condensers in capacities ranging from 0.1 mfd. to 2 mfd. are available. These are designed to work on potentials up to 2000 volts d.c. A block condenser is also made containing four sections, the first section being a 1000-volt 2-mfd. condenser, the second section a 600-volt 2-mfd. condenser, the third section a 400-volt 4-mfd. condenser, and the fourth section a 400-volt 1-mfd. condenser. Prices: Block condenser No. 690: \$18.00. Prices of individual condensers vary with size and voltage rating.

Manufacturer: Herbert H. Frost, Inc.

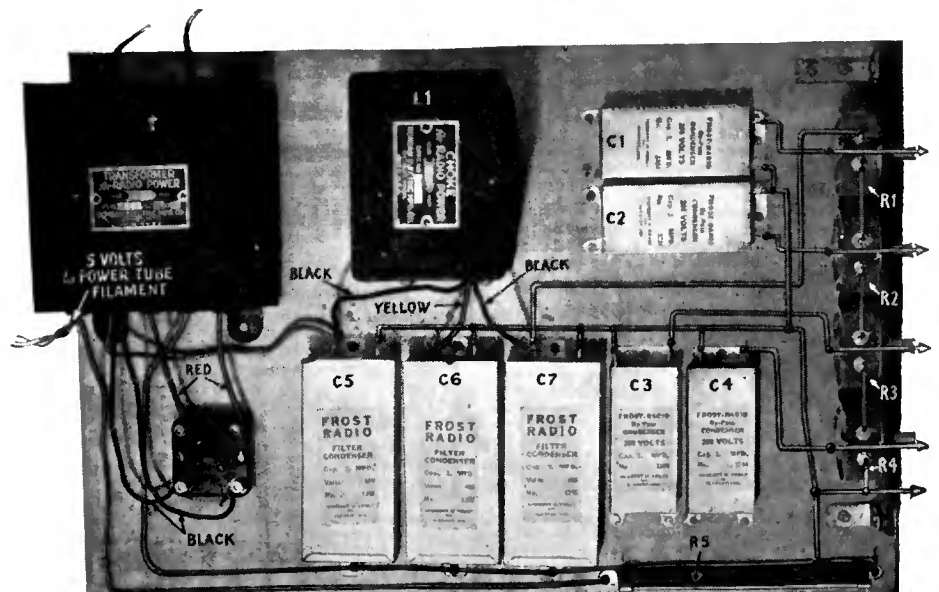

PICTURE DIAGRAM OF POWER SUPPLY

This picture shows the exact arrangement of apparatus and wiring in the B power-supply unit. The wires terminating in arrows on the right connect with the wiring harness of the receiver. The approximate potentials available at the various points follow: wire from R₁, 135 volts; wire from R₂, 90 volts; wire from R₃, 67 volts; wire from R₄, 45 volts, and the lower wire is the B minus connection

Manufacturers' Booklets

A Varied List of Books Pertaining to Radio and Allied Subjects Obtainable Free With the Accompanying Coupon

READERS may obtain any of the booklets listed below by using the coupon printed on this page. Order by number only.

1. FILAMENT CONTROL—Problems of filament supply, voltage regulation, and effect on various circuits. 1928 revised booklet, with circuit diagrams of popular kits. RADIALL COMPANY.

5. CARBORUNDUM IN RADIO—A book giving pertinent data on the crystal as used for detection, with hook-ups, and a section giving information on the use of resistors. THE CARBORUNDUM COMPANY.

12. DISTORTION AND WHAT CAUSES IT—Hook-ups of resistance-coupled amplifiers with standard circuits. ALLEN-BRADLEY COMPANY.

15. B-ELIMINATOR AND POWER AMPLIFIER—Instructions for assembly and operation using Raytheon tube. GENERAL RADIO COMPANY.

15a. B-ELIMINATOR AND POWER AMPLIFIER—Instructions for assembly and operation using an R. C. A. rectifier. GENERAL RADIO COMPANY.

17. BAKELITE—A description of various uses of bakelite in radio, its manufacture, and its properties. BAKELITE CORPORATION.

22. A PRIMER OF ELECTRICITY—Fundamentals of electricity with special reference to the application of dry cells to radio and other uses. Constructional data on buzzers, automatic switches, alarms, etc. NATIONAL CARBON COMPANY.

23. AUTOMATIC RELAY CONNECTIONS—A data sheet showing how a relay may be used to control A and B circuits. YAXLEY MANUFACTURING COMPANY.

30. TUBE CHARACTERISTICS—A data sheet giving constants of tubes. C. E. MANUFACTURING COMPANY.

32. METERS FOR RADIO—A catalogue of meters used in radio, with diagrams. BURTON-ROGERS COMPANY.

33. SWITCHBOARD AND PORTABLE METERS—A booklet giving dimensions, specifications, and shunts used with various meters. BURTON-ROGERS COMPANY.

37. WHY RADIO IS BETTER WITH BATTERY POWER—Advice on what dry cell battery to use; their application to radio, with wiring diagrams. NATIONAL CARBON COMPANY.

46. AUDIO-FREQUENCY CHOKES—A pamphlet showing positions in the circuit where audio-frequency chokes may be used. SAMSON ELECTRIC COMPANY.

47. RADIO-FREQUENCY CHOKES—Circuit diagrams illustrating the use of chokes to keep out radio-frequency currents from definite points. SAMSON ELECTRIC COMPANY.

48. TRANSFORMER AND IMPEDANCE DATA—Tables giving the mechanical and electrical characteristics of transformers and impedances, together with a short description of their use in the circuit. SAMSON ELECTRIC COMPANY.

53. TUBE REACTIVATOR—Information on the care of vacuum tubes, with notes on how and when they should be reactivated. THE STERLING MANUFACTURING COMPANY.

56. VARIABLE CONDENSERS—A bulletin giving an analysis of various condensers together with their characteristics. GENERAL RADIO COMPANY.

57. FILTER DATA—Facts about the filtering of direct current supplied by means of motor-generator outfits used with transmitters. ELECTRIC SPECIALTY COMPANY.

58. HOW TO SELECT A RECEIVER—A common-sense booklet describing what a radio set is, and what you should expect from it, in language that anyone can understand. DAY-FAN ELECTRIC COMPANY.

67. WEATHER FOR RADIO—A very interesting booklet on the relationship between weather and radio reception, with maps and data on forecasting the probable results. TAYLOR INSTRUMENT COMPANIES.

69. VACUUM TUBES—A booklet giving the characteristics of the various tube types with a short description of where they may be used in the circuit; list of American and Canadian broadcast stations. RADIO CORPORATION OF AMERICA.

72. PLATE SUPPLY SYSTEMS. Technical information on audio and power systems. Bulletins dealing with two-stage transformer amplifier systems, two-stage push-pull, three-stage push-pull, parallel push-pull, and other audio amplifier, plate, and filament supply systems. AMERICAN TRANSFORMER COMPANY.

73. RADIO SIMPLIFIED—A non-technical booklet giving pertinent data on various radio subjects. Of especial interest to the beginner and set owner. CROSLY RADIO CORPORATION.

76. RADIO INSTRUMENTS—A description of various meters used in radio and electrical circuits together with a short discussion of their uses. JEWELL ELECTRICAL INSTRUMENT COMPANY.

78. ELECTRICAL TROUBLES—A pamphlet describing the use of electrical testing instruments in automotive work combined with a description of the cadmium test for storage batteries. Of interest to the owner of storage batteries. BURTON ROGERS COMPANY.

81. BETTER TUNING—A booklet giving much general information on the subject of radio reception with specific illustrations. Primarily for the non-technical home constructor. BREMER-TULLY MANUFACTURING COMPANY.

84. FIVE-TUBE EQUAMATIC—Panel layout, circuit diagrams, and instructions for building a five-tube receiver, together with data on the operation of tuned radio-frequency transformers of special design. KARAS ELECTRIC COMPANY.

88. SUPER-HETERODYNE CONSTRUCTION—A booklet giving full instructions, together with a blue print and necessary data, for building an eight-tube receiver. THE GEORGE W. WALKER COMPANY.

89. SHORT-WAVE TRANSMITTING EQUIPMENT. Data and wiring diagrams on construction of all popular short-wave transmitters, operating instructions, keying, antennas; information and wiring diagrams on receiving apparatus; data on variety of apparatus used in high-frequency work. RADIO ENGINEERING LABORATORIES.

90. IMPEDANCE AMPLIFICATION—The theory and practice of a special type of dual-impedance audio amplification are given. ALDEN MANUFACTURING COMPANY.

Radio Broadcast

Laboratory Information Sheets

(Nos. 1-190)

in

BOUND VOLUMES

Ask any news dealer for "Radio Broadcast Data Sheets" or write direct to the Circulation Department, Doubleday, Doran & Co., Inc. See page 56 for further details. Price \$1.00

95. Resistance Data—Successive bulletins regarding the use of resistors in various parts of the radio circuit. INTERNATIONAL RESISTANCE COMPANY.

98. COPPER SHIELDING—A booklet giving information on the use of shielding in radio receivers, with notes and diagrams showing how it may be applied practically. Of special interest to the home constructor. THE COPPER AND BRASS RESEARCH ASSOCIATION.

99. RADIO CONVENIENCE OUTLETS—A folder giving diagrams and specifications for installing loud speakers in various locations at some distance from the receiving set, also antenna, ground and battery connections. YAXLEY MANUFACTURING COMPANY.

101. USING CHOKES—A folder with circuit diagrams of the more popular circuits showing where choke coils may be placed to produce better results. SAMSON ELECTRIC COMPANY.

102. RADIO POWER BULLETINS—Circuit diagrams, theory constants, and trouble-shooting hints for units employing the BH or B rectifier tubes. RAYTHEON MANUFACTURING COMPANY.

104. OSCILLATION CONTROL WITH THE "PHASATROL"—Circuit diagrams, details for connection in circuit, and specific operating suggestions for using the "Phasatrol" as a balancing device to control oscillation. ELECTRAO, INCORPORATED.

105. RECEIVING AND TRANSMITTING CIRCUITS. Construction booklet with data on 25 receivers and transmitters together with discussion of low losses in receiver tuning circuits. AERO PRODUCTS COMPANY.

108. VACUUM TUBES—Operating characteristics of an a.c. tube with curves and circuit diagram for connection in converting various receivers to a.c. operation with a four-prong a.c. tube. ARCTURUS RADIO COMPANY.

112. HEAVY-DUTY RESISTORS—Circuit calculations and data on receiving and transmitting resistances for a variety

In sending the coupon below, make sure that your name and address are included and are plainly written. Also make sure that the listing of booklets from which you choose is that of the latest issue of the magazine, as Radio Broadcast cannot guarantee the delivery of booklets not listed in its current issue.

USE THIS BOOKLET COUPON

RADIO BROADCAST SERVICE DEPARTMENT
RADIO BROADCAST, Garden City, N. Y.

Please send me (at no expense) the following booklets indicated by numbers in the published list above:

.....

.....

.....

.....

Name.....

(Number) (Street)

Address.....

(City) (State)

ORDER BY NUMBER ONLY

This coupon must accompany every request. RB 11-28

of uses, diagrams for popular power supply circuits, d.c. resistors for battery charging use. WARD LEONARD ELECTRIC COMPANY.

113. CONE LOUD SPEAKERS—Technical and practical information on electro-dynamic and permanent magnet type cone loud speakers. THE MAGNAYOX COMPANY.

114. TUBE ADAPTERS—Concise information concerning simplified methods of including various power tubes in existing receivers. ALDEN MANUFACTURING COMPANY.

115. WHAT SET SHALL I BUILD?—Descriptive matter, with illustrations, of fourteen popular receivers for the home constructor. HERBERT H. FROST, INCORPORATED.

118. RADIO INSTRUMENTS. CIRCULAR "J"—A descriptive manual on the use of measuring instruments for every radio circuit requirement. A complete listing of models for transmitters, receivers, set servicing, and power unit control. WESTON ELECTRICAL INSTRUMENT CORPORATION.

120. THE RESEARCH WORKER—A monthly bulletin of interest to the engineer and home builder. Each issue contains special articles on radio design and construction with special emphasis on resistors and condensers. AERVOX WIRELESS CORPORATION.

125. FILTER CONDENSERS—Some practical points on the manufacture and use of filter condensers. The difference between inductive and non-inductive condensers. POLYMET MFG. CORP.

123. B SUPPLY DEVICES—Circuit diagrams, characteristics, and list of parts for nationally known power supply units. ELEGRAD, INC.

124. POWER AMPLIFIER AND B SUPPLY—A booklet giving several circuit arrangements and constructional information and a combined B supply and push-pull audio amplifier, the latter using 210 type tubes. THORADSON ELECTRIC MFG. CO.

125. A. C. TUBE OPERATION—A small but complete booklet describing a method of filament supply for a.c. tubes. THORADSON ELECTRIC MFG. CO.

126. MEGOMETRIC RESISTANCE—How to use resistances for: Sensitivity control; oscillation control; volume control; regeneration control; tone control; detector plate voltage control; resistance and impedance coupling; loud speaker control, etc. CLAROSTAT MFG. CO.

129. TONE—Some model audio hook-ups, with an explanation of the proper use of transformers and chokes. SANGAMO ELECTRIC CO.

130. SCREEN-GRID AUDIO AMPLIFICATION—Diagrams and constructional details for remodeling old audio amplifiers for operation with screen-grid tubes. THORADSON ELECTRIC MFG. CO.

131. THE MERSON CONDENSER—An illustrated booklet giving the theory and uses of the electrolytic condenser. AMRAD CORPORATION.

132. THE NATIONAL SCREEN-GRID SHORT-WAVE RECEIVER—Constructional and operating data, with diagrams and photographs. JAMES MILLEN.

133. THE NATIONAL SHIELD-GRID FIVE—A circuit diagram with constructional and operating notes on this receiver. JAMES MILLEN.

134. REMBER SERVICE BULLETINS—A regular service for the professional set builder, giving constructional data, and hints on marketing. GRAY & DANIELSON MFG. CO.

135. THE RADIOBUILDER—A periodic bulletin giving advance information, constructional and operating data on S-M products. SILVER-MARSHALL, INC.

136. SILVER MARSHALL DATA SHEETS—These data sheets cover all problems of construction and operation on Silver-Marshall products. SILVER-MARSHALL, INC.

139. POWER UNIT DESIGN—Periodical data sheets on power unit problems, design, and construction. RAYTHEON MFG. CO.

140. POWER UNIT PROBLEMS—Resistance problems in power units, with informative tables and circuit diagrams. ELECTRAD, INC.

141. AUDIO AND POWER UNITS—Illustrated descriptions of power amplifiers and power supplies, with circuit diagrams. THORADSON ELECTRIC MFG. CO.

142. USE OF VOLUME AND VOLTAGE CONTROLS. A complete booklet with data on useful apparatus and circuits for application in receiving, power, amateur transmitter, and phonograph pick-up circuits. CENTRAL RADIO LABORATORIES.

143. RADIO THEORY. Simplified explanation of radio phenomena with special reference to the vacuum tube, with data on various tubes. DE FOREST RADIO COMPANY.

144. A. C. DETECTOR TUBE. Data on characteristics and operation of 2.5-volt a.c. detector tubes. ARCTURUS RADIO COMPANY.

145. AUDIO UNITS. Circuits and data on transformers and impedances for use in audio-amplifier circuits, plate and output impedances and special apparatus for use with dynamic speakers. SANGAMO ELECTRIC COMPANY.

146. RECEIVER CIRCUIT DATA. Circuits for using resistances in receivers, and in power units with descriptions of other apparatus. H. H. FROST, INC.

147. SUPER-HETERODYNE CONSTRUCTION. Construction and operation of a nine-tube screen-grid super-heterodyne. SET BUILDERS' SUPPLY COMPANY.

148. SHORT-WAVE RECEIVER. Constructional and operation data on a four-tube short-wave receiver. KARAS ELECTRIC COMPANY.

149. FIVE-TUBE SCREEN-GRID RECEIVER. Blueprint with full constructional details for building a broadcast receiver using two screen-grid tubes. KARAS ELECTRIC COMPANY.

150. FIVE-TUBE A.C. RECEIVER. Blueprint for constructing a five-tube a.c. receiver employing the "equamatic system." KARAS ELECTRIC COMPANY.

151. THE SECRET OF THE SUPER. Constructional and operation data on the Lincoln 8-80 One-Spot Super. LINCOLN RADIO CORPORATION.

152. POWER SUPPLY ESSENTIALS. Circuits and data on power-supply devices, and descriptions of power apparatus. POLYME MANUFACTURING COMPANY.

153. WHAT THE EVERADY FIDELITY CURVE MEANS TO RADIO RECEPTION. An analysis of the frequency range of musical instruments and the human voice which shows how these tones are reproduced by a receiver with an audio range of 60 to 5000 cycles. NATIONAL CARBON COMPANY.



Reap Big Dividends from this Investment in Tone Quality

A Thordarson Power Amplifier (Home Constructed) Will Transform Your Radio Into a Real Musical Instrument

WITH the insistent demand for quality reproduction, power amplification has become a vital radio necessity. Today, it is hard to find a radio set manufacturer who does not employ one or more power tubes in the output stage of his receiver.

There is no need, however, for you to discard your present radio instrument in spite of the fact that it is out-classed by newer models with power amplification. You can build a Thordarson Power Amplifier which, attached to your receiver, will provide a fullness and richness of reproduction that will equal or surpass the finest offerings of the present season.

Thordarson Power Amplifiers are exceedingly easy to assemble, even for the man with no previous radio experience. Only the simplest tools are used. Specific instructions with clear-cut photographs, layouts and diagrams insure success in home construction.

Whether your present receiver is factory made or custom built one of these amplifiers may be attached with equal ease. In fact, most Thordarson Amplifiers require absolutely no changes in

the wiring of the receiver itself, attachment being made by means of a special plug which fits the last audio socket of the receiver.

Thordarson Power Amplifiers for the home constructor and professional set builder range from the simple plate supply unit up to the heavy-duty three stage units employing the 250 type power tube in push-pull arrangement. These power amplifiers cover the requirements for every purpose and every pocket-book. They may be used with any type of horn, cone or dynamic speaker.

With a background of over thirty-three years manufacturing quality transformers, it is only natural that so many manufacturers of receiving sets of undisputed superiority have turned to Thordarson as the logical source of their audio and power supply transformers. The discriminating home constructor will do well to follow the lead of these manufacturers when buying his power amplifier.

Write to the factory today, enclosing 25c for the new "Power Amplifier Manual"—just off the press.

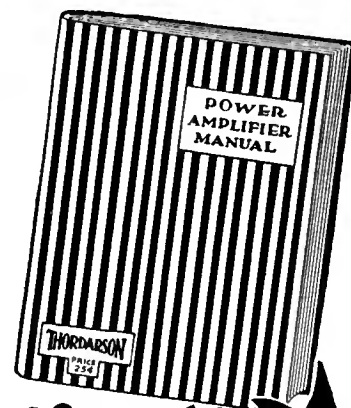

New!

No Amateur or Professional Set Builder Should Be Without This Book—

"POWER AMPLIFIER MANUAL"

A simple, yet complete, treatise on the subject of audio and power amplification, including full information on building, servicing, and testing power amplifiers in general. Also contains detailed specific construction data on twelve individual power units, with clear-cut layouts and diagrams of each.

25c

Send 25c in Cash or Stamps for This New Book—
Just Off the Press!

THORDARSON RADIO TRANSFORMERS

SUPREME IN MUSICAL PERFORMANCE

MAIL THIS COUPON TO-DAY!

THORDARSON ELECTRIC MANUFACTURING CO.
500 West Huron Street, Chicago, Illinois

Gentlemen: Please send me your new "Power Amplifier Manual" for which I am enclosing 25c.

Please send me free of charge your instruction sheet on the amplifier I have checked below:

171 Single . 171 Push-Pull . 210 Single . 210 Push-Pull (1 Stage) . 210 Push-Pull (2 Stage) . 250 Single (1 Stage) . 250 Single (2 Stage) . 250 Push-Pull (3 Stage) . 210 Phonograph Amplifier .

Name.....

Street and No.....

Town..... State.....



Melodies Caught
in Flight with

Cunningham
RADIO TUBES

As the Yule-logs crackle and music fills the air, enjoy the Christmas melodies to their utmost by having new Cunningham Radio Tubes in every socket of your radio.

These "ambassadors of joy" make delightful Christmas gifts.

E. T. CUNNINGHAM, Inc.
New York Chicago San Francisco

Manufactured and sold under rights, patents and inventions owned and/or controlled by Radio Corporation of America

The Radio Broadcast LABORATORY INFORMATION SHEETS

THE aim of the Radio Broadcast Laboratory Information Sheets is to present in a convenient form, concise and accurate information in the field of radio and closely allied sciences. It is not the purpose of the Sheets to include only new information, but to present practical data, whether new or old, that may be of value to the experimenter, set builder or service man. In order to make the Sheets easier to refer to, they are arranged so that they may be cut from the magazine and preserved, either in a blank book or on 4" x 6" filing cards. The cards should be arranged in numerical order.

Since they began, in June, 1926, the popularity of the Information Sheets has increased so greatly that it has been decided to reprint the first one hundred and ninety of them (June, 1926-May, 1928) in a single substantially bound volume. This volume, "Radio Broadcast's Data Sheets" may now be bought on the newsstands, or from the Circulation Department, Doubleday, Doran & Company, Inc., Garden City, New York, for \$1.00. Inside each volume is a credit coupon which is worth \$1.00 toward the subscription price of this magazine. In other words, a year's subscription to RADIO BROADCAST, accompanied by this \$1.00 credit coupon, gives you RADIO BROADCAST for one year for \$3.00, instead of the usual subscription price of \$4.00.

—THE EDITOR.

No. 241 RADIO BROADCAST Laboratory Information Sheet December, 1928

Supplying Power Devices from 220 volts A.C.

USE OF STEP-DOWN TRANSFORMERS

LETTERS are received frequently from readers in which the following question is asked, "I live in a district in which the only a.c. supply is 220 volts. How can I adapt a 110-volt B-power unit for operation on a 220-volt line?"

There are two methods by which this may be accomplished. First, a resistance of such a value as to produce a drop of 110 volts and leave remaining 110 volts for the power unit may be connected in series with the 220-volt line. This method is not very satisfactory, however, for the value of resistance which must be used varies considerably with different power units and with the load on the output of the power unit. Also, unless one has available instruments for measuring the a.c. voltages there is no simple means of determining what value of resistance must be used in order to reduce the line potential to 110 volts. If one has available an a.c. voltmeter this method can, of course, be used quite readily. The variable resistance is con-

nected in series with one side of the line, the voltmeter is connected directly across the input terminals to the power unit, and the resistance then adjusted until the voltmeter reads 110 volts.

The second method of adapting 110-volt B-power units for operation on a 220-volt line is somewhat more expensive, however, it is much simpler and does not require that any voltage measurements be made. This system of reducing a line potential to 110 volts calls for placing a separate power transformer between the power unit and the line. The transformer should have a step-down ratio of 2 to 1 so that with 220 volts across its primary 110 volts will be developed in the secondary winding.

The secondary is connected directly across the terminals of the B-power unit as indicated in the diagram. The same transformer may be used with any B-power unit so long as the input power to the B-power unit does not exceed the power rating of the step-down transformer. Such transformers are now made by several manufacturers.

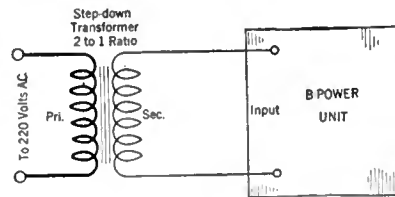

No. 242 RADIO BROADCAST Laboratory Information Sheet December, 1928

Resistance-Coupled Amplifiers

PREVENTING DISTORTION

AT VARIOUS times letters asking how to reduce distortion have been received from readers, who have constructed resistance-coupled amplifiers. The correspondent usually explains that the amplifier produces considerable distortion unless the volume is kept down very low. In this sheet we have endeavored to indicate what we consider the causes of the distortion.

As proof that a resistance-coupled amplifier, when properly constructed and operated, is capable of giving excellent results, we might refer to the use of such an amplifier in the demonstration of television by the Bell Telephone Laboratories. In this work an amplifier of this type was used to amplify the output of the photo-electric cell and it was essential that the audio response curve be practically flat over a very wide frequency band. Distortion in an amplifier of television signals would be much more serious than similar distortion in the amplification of music, the eye being a much more critical judge of quality than the ear.

What, then, is the probable cause of the distortion which many notice when using such an amplifier? The answer is, first overloading of the amplifier, and secondly, common coupling in the plate-voltage

supply, be it batteries or a power unit, although, of course, such coupling generally will be more serious in the latter case.

If any of the tubes in a resistance-coupled amplifier are overloaded so that the grid of one or more tubes goes positive, some grid current will flow and produce so-called "blocking." If the overloading is very slight, the blocking may not be noticeable as such, but the amplifier will distort. The important point is that the blocking does not affect only the signal which caused the blocking but will also affect the following signals until the blocking current leaks off through the high-resistance grid leak. If the signals were fed into a transformer-coupled amplifier some overloading might occur but the tubes would not block because the transformer windings are of low resistance in comparison with the resistance of the grid leaks used in a resistance-coupled amplifier.

The resistance-coupled amplifier is, therefore, much more critical with regard to overloading, than a transformer-coupled amplifier, and in the operation of the former type of amplifier the signal input must be kept down to a level at which no overloading occurs.

Laboratory Sheet No. 243 discusses a second cause of distortion in resistance-coupled amplifiers, i.e., common coupling in the plate-supply circuits.

THE COMPLETE LINE OF QUALITY RADIO PARTS

FROST-RADIO



FROST VOLUME CONTROL

Gives complete, stepless and wonderfully smooth control of volume and oscillation. Wearproof roller contact arm, Bakelite case and dust cover. \$2.00 and \$2.25.

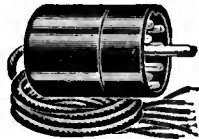

FROST ALL-BAKELITE CABLE PLUG

Terminals cannot work loose even when overheated. Color code moulded into Bakelite. Best quality cable, with colored rubber insulation on wires. Has 5 ft. seven-strand braid covered cable. Plug and cord only, \$2.25. Baseboard or sub-panel socket, 75c.



FROST CONVENIENCE OUTLETS

Plt. std. outlet box Brush brass or Bakelite plates. \$1.00 to \$3.25.

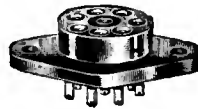

FROST HUM BALANCER

Simply turn the slotted head shaft with screw driver to regulate. Smooths the ripple out of A.C. current. Precision built, \$1.00.

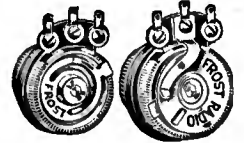

FROST GEM RHEOSTATS

Made to deliver a service that is not usually expected from little rheostats like these. Mighty good little rheostats, taking up little space and supplied either plain or with D.C. switch. Easy to solder to. Plain, 75c. With switch, \$1.00.

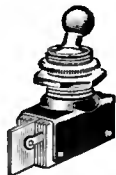

FROST APPROVED A. C. SWITCH

Single hole mount 110 volt A.C. Snap Switch. Tested to 250 volts, 3 amps. Underwriters' approved. 75c.



FROST VOLUME CONTROL WITH A. C. SWITCH

We equip our famous Volume Control with approved A.C. Snap Switch tested to carry 250 volts at 3 amperes, so that both switch and volume control may be handled by single knob. \$2.75 and \$3.00.



FROST MOULDED MICA CONDENSERS

Cannot be affected by moisture or climate Moulded Bakelite with finest mica dielectric. Easy to attach. 45c to 90c.

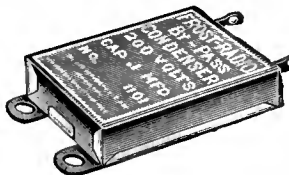

FROST BY-PASS CONDENSERS

Made from finest materials, thoroughly seasoned, vacuum impregnated and hermetically sealed. Accurate capacities and conservative voltage ratings. 1 to 2 mfd. 80c to \$2.00.



FROST FIXED RESISTANCES

Die cut flexible Bakelite strip holds windings firmly in place. Terminals are staked into Bakelite. .4 to 1000 ohms. Also as center tapped resistances, 6 to 64 ohms. 15c to 50c.



FROST BAKELITE RHEOSTATS

Long the standard air cooled Bakelite Rheostat, as well as the original of this type. Resistance wire is wound on die cut Bakelite strip over moulded Bakelite frame. Wide choice of resistances. \$1.00 and \$2.50.



FROST VOLUME CONTROL WITH D. C. SWITCH

Equipped with sturdy German silver switch mounted on Bakelite panel, and with switch points fitted with sterling silver contacts, this Volume Control gives quick operation, positive-locking off position and saves space. For battery operated sets, \$2.35.

FROST BLOCKING CONDENSERS

Every particle of material used is of tested quality. Entire condenser enclosed in hermetically sealed cases after vacuum impregnation. Gold bronze lacquer finish; tinned terminals. \$18.00.

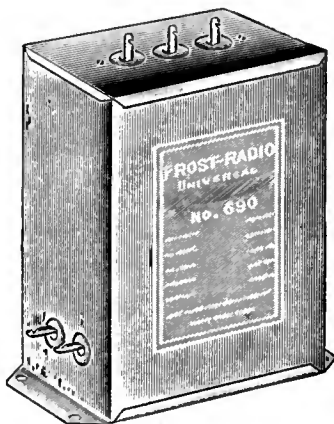

FROST HEAVY DUTY FILTER CONDENSERS

We use only finest quality linen paper and highest grade foils in building these Filter Condensers. Conservative ratings. Designed to give longest service with entire freedom from trouble. .5 to 2 mfd. \$1.40 to \$7.00.



FROST GEM VOLUME CONTROL

Identical with our standard size Volume Control units except in size. Gem units are only 1 1/2 in. in diameter, and 3/8 in. thick. Great space savers. \$2.25 and \$2.50.



FROST BAKELITE RHEOSTATS WITH D. C. SWITCH

Cleverly mounted German silver D.C. battery switch is firmly attached to Bakelite panel on back of rheostat, affording quick on and off control of filament current. 2 to 75 ohms. \$1.35.



Coupon Brings Complete Frost Catalog

It costs but little—and contains a vast amount of valuable information about rheostats, volume controls, switches, jacks, plugs, condensers, circuits, etc. It's a book every fan should have. Fill out and mail coupon to-day for your copy.

HERBERT H. FROST, INC.

Main Office and Factory: ELKHART, IND.

New York City

CHICAGO

San Francisco

HERBERT H. FROST, Inc.
160 No. La Salle Street, Chicago

Send me your new Frost Data Book, containing valuable radio information and facts about your complete line of parts. I enclose 10c.

My name

Street Address

City State

(Are you a professional set builder?.....)

Thousands ~
call CeCo the
clearest toned
longest life -
tube on the
market



...and it ought to
be—here's why

THE finest materials skillfully employed by able craftsmen and the foremost laboratory experts give CeCo marked advantages over other tubes.

They have not only a purer, clearer, more pleasing tone, but a longer, more serviceable life.

Try them! Sold everywhere.

CeCo Mfg Co., Inc. Providence, R. I.

CECO Radio
Tubes

No. 243

RADIO BROADCAST Laboratory Information Sheet December, 1928

Resistance-Coupled Amplifiers

EFFECT OF COMMON COUPLING

LABORATORY Information Sheet No. 242 gave some data on distortion in resistance-coupled amplifiers due to overloading. A second cause of distortion (which applies to this type of amplifier as well as to any other type of amplifier) is that due to common coupling between the plate circuits of the various tubes. This form of coupling is generally due to the resistance or reactance of the plate-supply device.

In a resistance-coupled amplifier the phase relation of the input voltage and the output voltage is practically 180 degrees, and, therefore, if any signal voltage from the plate circuit is returned to the grid circuit in any way, this feed-back voltage will be in exact opposition to the original input voltage and will tend to decrease the amplification. In a multi-stage amplifier the various feed backs from the different circuits combine; in some instances they may neutralize each other but more frequently they produce regeneration or anti-regeneration, either of which distorts the frequency characteristic of the amplifier so that good quality is not obtained.

To prevent common coupling in the plate-supply unit it is essential that the grid and plate circuits of each of the amplifier tubes be filtered so that none of the signal currents have to pass through the plate supply unit. In this way common coupling and its effects are prevented.

Laboratory Information Sheet No. 193 illustrated a circuit for preventing resistance-coupled amplifiers from motorboating. The circuit presented afforded a means of thoroughly filtering the plate circuit to the detector tube and it was found by experiments in the Laboratory that such a circuit will almost invariably prevent an amplifier from motorboating. This circuit can also be used advantageously with transformer-coupled amplifiers, it frequently being found that oscillations in amplifiers of this type can be prevented easily by this means.

In a later Laboratory Information Sheet we will illustrate a resistance-coupled amplifier with filter circuits in each of the various plate and grid leads. This sheet will explain what determines the values of resistance and capacity generally used in such filters.

No. 244

RADIO BROADCAST Laboratory Information Sheet December, 1928

Alternating-Current Ratings

EFFECTIVE VS. PEAK VOLTAGES

AT THE present time there are several devices used in radio receiving sets, such as power transformers, filament transformers, filter condensers, etc., which are rated in terms of a.c. voltages. References are made frequently to the peak value of an alternating-current voltage, to the effective value of such a voltage, and to the r.m.s. value of the voltage. The significance of these various terms is explained in this sheet.

The first and most important point is that alternating-current apparatus almost invariably is rated in terms of effective voltage, and effective voltage has exactly the same meaning as the r.m.s. voltage so that these two terms may be used interchangeably. If the secondary of a power transformer is rated at 350 volts it means that the effective value of the voltage is 350. Power lines in homes

generally have an effective value of voltage of about 110 volts. The filaments or heaters of alternating-current tubes are rated in terms of effective voltage.

The letters r.m.s. are an abbreviation for root-mean-square, this value of an alternating voltage being such that it gives exactly the same heating effect as a direct current of the same potential. It is for this reason that the r.m.s. value of an alternating voltage is termed the effective value.

The peak value of an alternating voltage is the maximum value to which the voltage rises during any part of the cycle. The shape of a.c. voltages with which one ordinarily deals are such that the potential is proportional to a sine of an angle and it is for this reason that we frequently hear the term "sine wave." If the voltage wave has such a form then the peak value is equal to 1.41 times the effective or r.m.s. value.

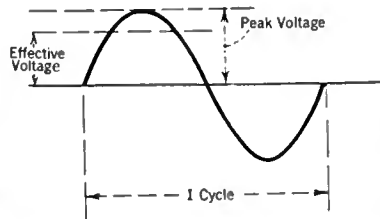

No. 245

RADIO BROADCAST Laboratory Information Sheet December, 1928

Power Output

HOW MUCH IS REQUIRED

IN THE last audio stage of one's receiver there are more than half a dozen arrangements that can be used. We might use a single 171A or two of these tubes in push-pull, but perhaps some prefer a single 210, a single 250 or either of these tubes in push-pull. From these and other combinations one can obtain equally good quality provided the tubes are not overloaded. The question one naturally asks is what tube or combinations of tubes he should use? How much power output does one need for ordinary home reproduction? These are questions about which we all want definite information, but which unfortunately cannot be answered very simply.

How much power is available from any one tube or combination of tubes can be determined by referring to the table published on Laboratory Sheet No. 246. Although opinions differ as to how much power is required for ordinary home reproduction, George Crom, Engineer of the American Transformer Company, in a recent paper read before the Radio Club of America, states that for a sound level slightly above normal, using a good loud speaker, from 1 to 1.5 watts input power is required. By referring to the table on Laboratory Sheet No. 246 it would appear, therefore, that to obtain a power output of about 1.5 watts we must use either a single

210-type tube, a 250-type tube operated at low voltage or lower power tubes, such as the 171A operated in push-pull or parallel.

The phrase "normal output" referred to in the preceding paragraph is obviously a rather ambiguous one, and, since the ear is not especially sensitive to variation in power, it is probable that an increase or decrease of 3 TU would not affect seriously the loudness as heard by the ear. 3 TU corresponds to a power ratio of approximately 2. In other words, variations from 1 to 2 watts in the power available in the output circuit would not produce very great changes in volume.

The table given on Laboratory Sheet No. 246 will also be helpful in determining the power output of any power amplifier that one may have or may contemplate purchasing. For example, if the power amplifier uses two 171A-type tubes in push-pull, then the power output will be about three times that of a single tube or 2100 milliwatts. Large power amplifiers are used frequently to supply several loud speakers in an auditorium, hotel, etc. An approximate determination of the number of loud speakers which such an amplifier can supply may be obtained by remembering that each loud speaker requires approximately 1.0 watt, and then the number of loud speakers which can be supplied may be determined easily.

**VELVET
Socket-B
power for
your Radio**



**list price
less tube**
\$ **26.50**

A REALLY FINE PRODUCT AT A POPULAR PRICE

VELVET . SILENT . HUM . FREE . OUTPUT
FOOL . PROOF . SAFETY . VOLTAGE . ADJUSTMENTS
USING . THE . SAME . RECTIFIER . TUBE . AS . THE
HIGHEST . PRICED . A . C . SETS . THE . UX . 280
RUNS . SETS . UP . TO . SIX . TUBES . AND . GIVES
FULL . 180 . VOLTS . FOR . 171 . POWER . TUBE

Licensed under  Patents

**V. NATIONAL. B
ELVET**

SEND FOR BULLETIN NO. 132 R. B.

NATIONAL CO. INC.

ESTABLISHED 1914
W. A. READY, PRES.

MALDEN, MASSACHUSETTS

How Many Lives has a TELEVISION TUBE?



List Price
\$7.50

Raytheon Kino-Lamp

The name Raytheon on any type of tube assures a service-life so long that it is often equivalent to the lives of two or three ordinary tubes.

The principles of sturdiness and strength developed in the production of Raytheon sound-reception tubes have been applied to the manufacture of Raytheon television tubes.

The Raytheon Kino-Lamp is the long-life television receiving tube—adapted to all systems, and made in numerous types.



Raytheon Foto-Cell

The long-life television sending tube, in either hard-vacuum or gas-filled types, and in two sizes of each.

Information and Prices upon application

Correspondence is invited from all interested in television

RAYTHEON MFG. CO.
CAMBRIDGE · MASS.

No. 246

RADIO BROADCAST Laboratory Information Sheet December, 1928

Power Output Characteristics of Vacuum Tubes

A USEFUL TABLE

THE table below gives the power output of the various types of power tubes used in radio receiving sets. The table has been arranged in order of power output, starting with the 120-type tube with a power output of 110 milliwatts and ending with the 250-type tube with a power output of

4650 milliwatts. If two tubes are used in a push-pull amplifier, then the power output of the combination will be equal approximately to three times the power output of a single tube. Two more or tubes used in parallel will have a power output equal to the power output of a single tube multiplied by the number of tubes used.

Tube	Plate Voltage	Negative Grid Voltage	Milliwatts* Power Output	Tube	Plate Voltage	Negative Grid Voltage	Milliwatts* Power Output
120	135	22.5	110	250	250	45	900
112A	135	9	120	210	350	27	925
171A	90	16.5	130	210	400	31.5	1325
112A	157	10.5	195	250	300	54	1500
171A	135	27	330	210	425	35	1540
210	210	18	340	250	350	63	2350
210	300	22.5	600	250	400	70	3250
171A	180	40.5	700	250	450	84	4650

*1000 milliwatts is equal to 1 watt of energy.

No. 247

RADIO BROADCAST Laboratory Information Sheet December, 1928

Frequency Characteristics of Television Amplifier Developed by the Bell Telephone Laboratories

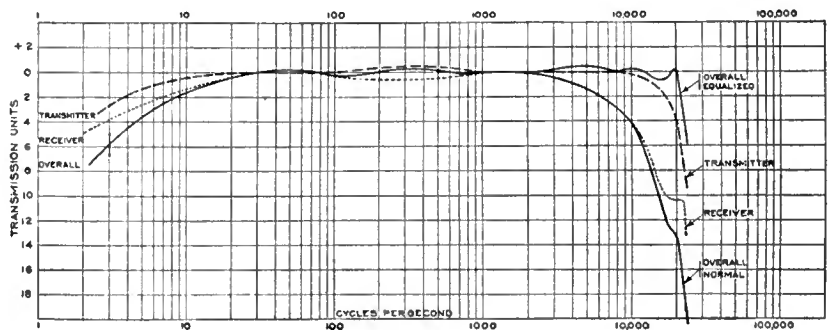

No. 248

RADIO BROADCAST Laboratory Information Sheet December, 1928

Television

AMPLIFIER CHARACTERISTICS

ON LABORATORY Sheet No. 247 are published a group of curves taken from the October, 1927 *Bell System Technical Journal* where the apparatus used in connection with the demonstration of television made by the Bell Telephone Laboratories was described. In this demonstration a complete radio system was used. The television transmitter was located at the transmitting station and the output of the television transmitter, after being amplified, was sent over the air, the frequency of the radio transmitter being 1450 kilocycles. A superheterodyne receiver was used at the receiving end, and the television signals, after being detected, were sent through the necessary amplifiers and finally made to modulate the neon tube used in the television receiver. In order to insure that the reproduction of the picture might not suffer distortion careful frequency measurements were made on all of the apparatus and the results of these tests were plotted and are reprinted on Laboratory Sheet No. 247. The dash curve gives the characteristic of the radio transmitter and it is

evident from the curve that the frequency characteristic of this system is excellent. There was practically no loss down to 10 cycles and only a 4 TU loss at 20,000 cycles.

The receiver characteristic is indicated by the dotted curve. At 10 cycles there was a loss of about 1.5 TU. At 10,000 cycles there was a loss of about 4 TU and at 20,000 cycles a loss of 10 TU. The "overall normal" curve indicated as a solid line shows about 1.5 TU loss at 10 cycles and a loss of about 13.5 TU at 20,000 cycles. This characteristic was unsatisfactory since the engineers had determined previously that it was desirable that the frequency characteristic be constant within about 2 TU. up to 20,000 cycles.

The necessary improvement in the characteristic was obtained by the use of equalizers and the final curve of the equalized system is indicated by "overall equalized." This overall curve is down about 1.5 TU at 10 cycles and there is 0 TU loss at 20,000 cycles. Between these two limits there are slight variations in the curve although none of these variations are as large as 1 TU.

THE NEW 5000 HOUR ELKON METALLIC RECTIFIER FOR "B" ELIMINATORS

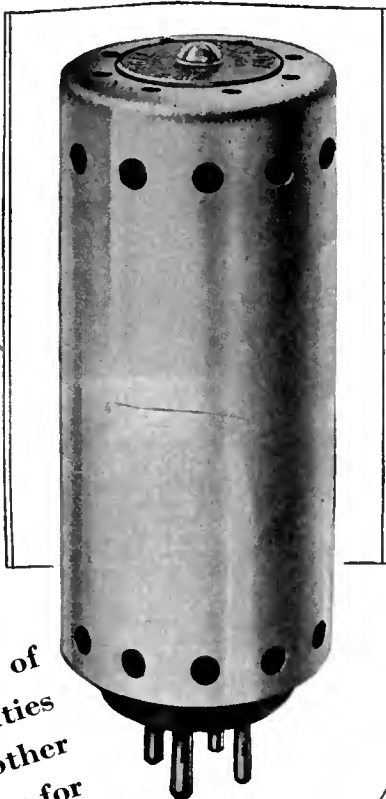

At last a dry high-voltage rectifier! All of the advantages of a tube—none of its frailties—much longer life—more efficient—smoother power—no noise—now as perfect a rectifier for the "B" end as the Elkon "A" Rectifier—stand-ard with "A" Eliminator manufacturers. And the Elkon Rectifiers are Self-Healing—line surges or accidental overloads are automatically taken care of—no permanent injury is done.

The Elkon EBH replaces BH type tubes in "B" Elimimators. Simply take out the fragile 1000 hour tube and plug in the husky Elkon EBH 5000 hour Rectifier. Same characteristics, but what an improvement.

Use the Elkon EBH Rectifier! Eliminate all uncertainty of life, of successful operation. Build your own new "B" Eliminator or convert the one you have to up-to-the-minute radio efficiency.

Radio Department
ELKON, Inc.
Division of P. R. Mallory & Co., Inc.
350 Madison Ave. New York City

ASK ABOUT THE OTHER ELKON RECTIFIERS, TOO
M-16 for "A" Elimimators and 3 ampere chargers, V-4 for trickle chargers—and the authorized Hal kite Replacement Rectifiers BNK and BJ.

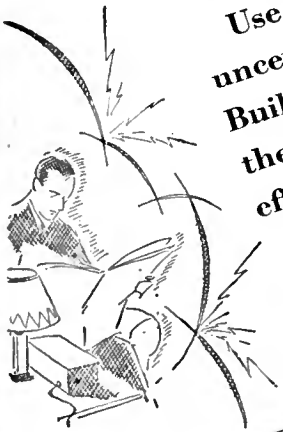

ELKON, Inc., Dept. E-30
350 Madison Ave., N. Y.

Kindly send me complete information on Elkon Quality Radio Products.
Name.....
Address.....

An Investment That Pays DIVIDENDS

An indicating instrument is an essential part of the equipment of every good radio receiver installation, since it aids in maintaining efficient operation, secures the best reception and fully protects the financial investment.

To advanced radio enthusiasts and those having professional connections with the industry, the selection of instruments is highly important. Unfailing reliability is the first consideration since accuracy of measurement is a fundamental requisite of success in both research work and commercial activities, and pays the biggest dividends on the investment—whether of time or money.

Illustrated herewith are the Weston Portable A. C. and D. C. instruments which are extremely popular for general radio service and make ideal personal instruments.

Three-Range Instruments for A. C. and D. C. Operated Sets



The fine workmanship, excellent characteristics and dependable performance of these models—No. 528 A. C. and No. 489 D. C.—merit an unquestioned preference over all other makes. Moderate in price, too. Enclosed in beautifully finished bakelite cases—black for D. C. and mottled red and black for A. C. instruments. 750/250/10 volts (1000 ohms per volt resistance) for D. C. service, and 150/8 1/4 volts for A. C. testing.



Single and Double-Range Instruments

These same models, identical in size and appearance to the above and enclosed in the same bakelite cases, are also furnished as D. C. double-range Voltmeters—(with either 1000 or 125 ohms per volt resistance) and as single and double-range Ammeters. For A. C. testing they are supplied as single-range Ammeters and Milliammeters and double-range Voltmeters.

All instruments of the Weston Radio Line are completely described in Circular J—just off the press. Write for your copy.

Weston Electrical Instrument Corporation
604 Frelinghuysen Ave.,
Newark, N. J.

WESTON RADIO INSTRUMENTS

Jenkins & Adair Microphone Mixing Panel TYPE 3-B

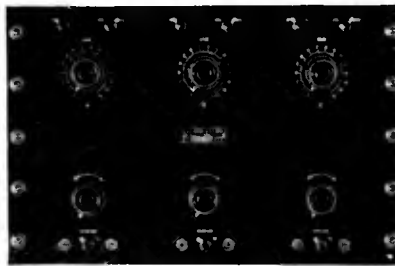

For Broadcasting, Electrical Recording, and Power Speaker Systems

THE 3-B Mixing Panel is designed to accommodate almost any combination of pickup circuits up to a total of six. Any three of these may be made to pass through the three Compound Mixing Controls at the same time, and instantaneous switching is available for the remaining circuits.

The incoming circuits may consist of condenser transmitters, carbon microphones, telephone lines or low impedance photograph pickup devices, in practically any combination. When a single input circuit of extremely low level is encountered, the positions not in use may be cut entirely out of the system, thus causing no loss whatever to the weak incoming signal.

The panel is 5 1/2" x 16" black sanded Bakelite, 19 in. wide and 12 1/2" in. high. Detailed information and circuit is shown in bulletin No. 7, which we will be glad to mail to you. The net price in the U. S. A. and Canada is \$275.00, F. O. B. Chicago.

J. E. JENKINS & S. E. ADAIR, Engineers
1500 N. Dearborn Parkway,
Chicago, U. S. A.
Send for our bulletins on Broadcasting Equipment

Before Buying any "A" Eliminator

Get my authorized Discount Card and complete description of the finest "A" Power Kit ever offered.

DAVID W. KNAPP, Inc.
Knapp Electric, Inc.
Division of P. R. Mallory & Co., Inc.
Room 411, 350 Madison Ave. N. Y. C.

Radio HEADQUARTERS

The newest radio wrinkles—A-C, grid tube, short wave, television, dynamic speakers, newest tubes and circuits—anything and everything in radio—are now ready for you at Barawik's. With elections, football, National broadcasting, Box and other big doings filling the air, thousands of newcomers will take to radio this year as never before. Business will be good—Set builders will make money. You can clean up big by buying from Barawik—the oldest, biggest, most reliable radio house in the world. Let us prove it. Send now for the Big Book—all ready for you—free. Get the latest radio information and lowest prices.

BARAWIK CO.
CANAL ST.,
CHICAGO, U.S.A.

This Big Book Sent to You Free



Name.....
Address.....
City.....

TONE



Push-pull Transformers with impedances to match power tubes and dynamic speakers

Type "BX" Input Transformer has extremely high primary inductance. Secondary accurately divided.

Price, each.....\$6.50

Type "GX-210" Output Transformer. Especially designed for push-pull amplifier using UX-210 or CX-310 tubes. Secondary connects directly to moving coil of dynamic speaker.

Price, each.....\$6.50

Type "HX-171" Output Transformer. Same as above except impedance matches UX-171, CX-371, or UX-250, CX-350 tubes.

Price, each.....\$6.50

Free circular giving audio hook-up and complete information on request

SANGAMO ELECTRIC COMPANY

Springfield

Illinois

Letters from Readers

As a Few Readers See It

EVERY editor is delighted when he receives unsolicited praise from readers of his publication, and we are not exceptions to this rule. However, some forms of appreciation have a much deeper meaning than others. For example, a compliment, which is often found in a letter making a request, often is included to make the communication as courteous as possible. On the other hand, a letter which is written solely for the purpose of expressing an opinion on an article or the publication in general, is considered much more sincere.

This month's mail has contained a great number of letters that have made us feel warm all over. This correspondence shows us that many of our readers are not only in sympathy with our editorial policy, but are enthusiastic about it. These are facts we like to know, but we are interested equally as much when a letter can offer constructive criticism, or suggest a means of improving the magazine.

The following is a letter from a set builder in Nova Scotia, Canada, who has just finished reading his first copy of RADIO BROADCAST:

To the Editor:

I am a set builder and greatly interested in everything pertaining to radio. I read most of the radio magazines that come down this way, but, strange to say, I never read RADIO BROADCAST until to-day. Of course, I need not tell you that I was greatly chagrined to see what I've been missing, and, to guard against any further vexation on this account, I told the clerk in the book store at Sydney to save a copy for me every month.

I find your "Home-Study Sheets," "Laboratory-Information Sheets," and "Service-Data Sheets on Manufactured Receivers," very interesting, and more instructive than anything I have seen in any of the other radio magazines. About all that RADIO BROADCAST needs to put it head and shoulders over all the other radio magazines is a good trouble-shooting page. If you were to take the receivers described in your "Service-Data Sheets on Manufactured Receivers," and trouble shoot them from input to output, I believe you would be doing the service men, set owners, and readers an inestimable service and greatly increase the circulation of your magazine.

M. H. McDONALD.

Another radio service man who derives much pleasure and information from reading our columns is H. R. Happoldt, of Savannah, Ga. In his letter he also suggests that we devote more space to problems in radio servicing.

To the Editor:

It gives me great pleasure to make myself known as a regular reader of RADIO BROADCAST, and to say the following: I have been connected directly with radio for more than 11 years and I read all radio magazines. I can say truthfully that your magazine proves of greater interest and benefit to me than any other. My greatest interest is in the radio servicing work, and I would like to see even more space in your valuable publication given over to this end.

H. R. HAPPOLDT,
Chief Radio Operator, S. S. Gloucester.

For some time we have had in mind inaugurating a special section for the radio service man and such a department, "The Service Man's Corner," is started on page 101 of this issue. It will appear regularly in the future.

Excerpts from two other letters which express opinions on our editorial policy follow:

To the Editor:

I am an electrical control engineer. One of the
(Continued on page 139)

Tyrman Imperial "80"
Custom-Bilt Shielded Grid

A-C
Shielded
Grid
Tubes

Short
Wave
Plug-in
Coils

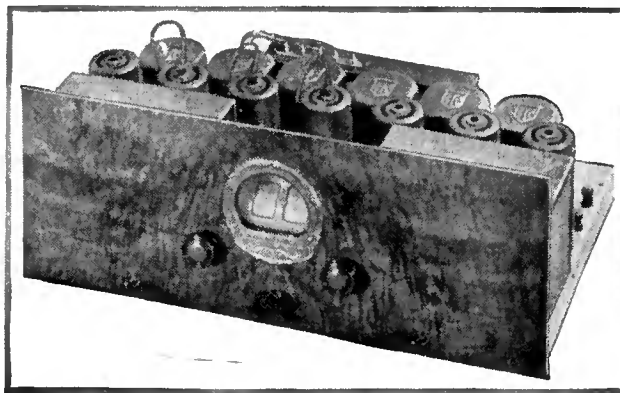

310 or
350
Power
Amplifier
Tube

Permanent
Phonograph
Connection

Tyrman "80" full A-C Socket operation using (3) A-C Shielded Grid (4) 327 (2) 381 (1) 350 or 310 Tubes. Dimensions 8" x 21" x 11 1/2". One Spot-10 K.C. Separation. "The year ahead receiver."

"Never have I operated a radio like the Tyrman '80'"

"A revelation! . . . It has everything. Selectivity, Sensitivity, Tone and Power . . . A station every point on the dial from top to bottom . . . The slightest touch separates stations in this congested locality . . . Distance comes in like local . . . Congratulate you on beautiful, natural tone . . . Short wave reception great . . . Held W2XAD at 21.96 meters for six hours . . . I have built about every circuit but never have I operated a receiver like the Tyrman '80' for all around satisfactory performance."

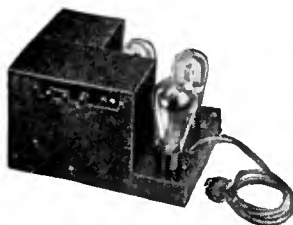

"80" Power Supply

Powerful—Compact. Dimensions 8 1/2" x 11" x 6 1/4". Phone tips provided for any type speaker. Directly energizes field of Dynamic Speaker. Factory packed, completely wired.

Compare Tyrman Receivers, point for point, dollar for dollar with any. You will realize why Dealers and Set Builders are so enthusiastic . . . why they are making money.

Send for FREE BOOK showing schematic and wiring diagrams with full descriptions.

TYRMAN ELECTRIC CORPORATION
Dept. 319, 314 W. Superior St.
CHICAGO, ILL.

America's Verdict

These and hundreds of other expressions from Dealers, Set Builders, Engineers and Editors all over the country tell us of the outstanding performance not only of the Tyrman Imperial "80" but of the Tyrman "72" and "60" as well. Proof of Tyrman quality and leadership in Custom Built Receiver design is Sales. Orders are literally pouring in. Repeat orders. That's the test. Our factory is working to capacity, but day and night work enables us to make prompt shipments.

Tyrman "80" parts including Short Wave Coils and wired Power Pack complete, ready to assemble, \$199.50 list.

Tyrman "72" parts for battery or diminator operation, complete ready to assemble, \$98.50 list.

Special Power Supply for "72" wired, \$55.00 list.

Tyrman "60" parts for battery or diminator operation complete, ready to assemble, \$69.50 list.

TYRMAN ELECTRIC CORPORATION
Dept. 319, 314 W. Superior St.
Chicago, Ill.

Without obligation, send me free literature describing Tyrman "80" for A-C operation , Tyrman "72" A-C , Tyrman "72" battery operation , Tyrman "60" battery operation .

Name

Address

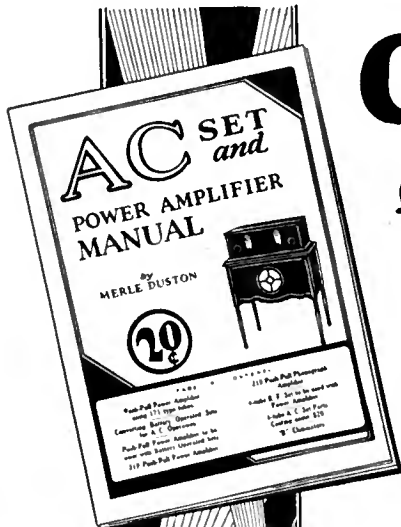

Choose from the Year's most Successful Designs

—practical helps for amateur and professional Builders

Here are described—and illustrated—in understandable, interesting terms, the newest designs in A C Power Amplifiers. Every single one has been proved practical.

This authentic A C Manual is the work of Merle Duston, well-known engineer and the author of many radio texts books. Mr. Duston has condensed in this valuable volume the best efforts of the industry covering the past year of Radio's greatest development.

Any builder—amateur or professional—can construct a set or power amplifier of the most approved design from the instructions in this text book. And for general reference to the new tubes and parts the Duston A C Manual should be in the possession of every up-to-date radio enthusiast.

A limited supply of this splendid A C Manual is available through the Dongan Laboratories. Send 20 cents for a copy to be mailed to you.

DONGAN ELECTRIC MFG. CO.
2991-3001 Franklin Street
Detroit

Dongan Electric Mfg. Co.
Send copy of Duston's A C Manual to

Name

Street

City..... State.....

20c inclosed

TRANSFORMERS of MERIT for FIFTEEN YEARS

AC Electric Power Speaker GEMBOX

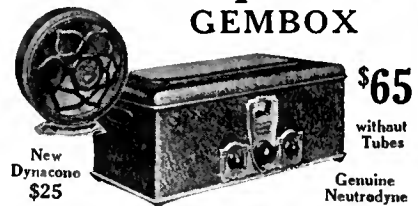

New Dynacone \$25
without Tubes
Genuine Neutrodyne

Crosley radio sets have always been good sets. In them the public has always received the utmost value. The AC Electric power speaker GEMBOX at \$65 is the world's lowest priced power speaker radio. Every modern feature available, to insure good reception, is incorporated in the Crosley Gembox.

5 DAYS' FREE TRIAL
Try the Gembox and the new DYNACONE in your own home. Test it! Compare! Its realistic tone and rich reproduction is amazing!



8-Tube A C Electric SHOWBOX \$80
Genuine Neutrodyne with all modern improvements.

6 Tube Battery Operated BANDBOX \$35
Genuine Neutrodyne for places where electric current is not available for electric receivers. Dry Cell Battery Type. BANDBOX, Jr., \$35

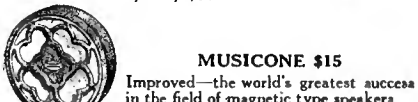

MUSICONE \$15
Improved—the world's greatest success in the field of magnetic type speakers.

CROSLEY
THE CROSLEY RADIO CORPORATION
Dept. 20
Powel Crosley, Jr. Pres. Cincinnati, Ohio
Montana, Wyoming, Colorado, New Mexico and west prices slightly higher
Prices of Crosley receivers do not include tubes

A Small Part with a BIG JOB

AMPERITES take little space, but they control the very life blood of your receiver by automatically regulating the tube filaments.

It pays to use AMPERITE—the only self-adjusting resistance for "A" current. Maintains filament temperature at proper voltage despite variations in supply. Essential with eliminators. Entirely unlike fixed resistors. Instantly interchangeable. Banishes hand-rheostats. Beautiful panel layout. Saves wiring. A type for every tube—battery or A. C. \$1.10 with mounting (in U.S. A.), at all dealers.

Radiall Company
50 FRANKLIN ST., NEW YORK

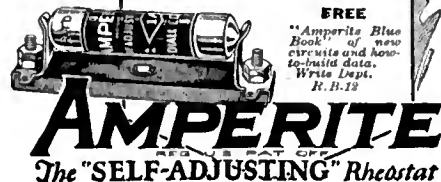

\$75 to \$125 Weekly

Charging Batteries Starts You

Let me show you how to make big money right from the start. I've prepared a FREE book explaining all details. First week's profit pays for all equipment. You can get all the battery charging business in your community with my Service Station Charger—it's years ahead of ordinary chargers—handles 50% to 70% more batteries. I explain everything—start you in a business of your own and put you on the way to big money. Write for FREE BOOK.

C. F. HOLMES, Chief Engineer, Dept. R B
Independent Electric Works
3116 Ravenswood Ave. Chicago, Ill.

FREE BOOK—Just Out



Before Buying

Any "A" Eliminators

Write me about the discount card which enables you to purchase the new and improved

Knapp "A" Power Kit at a liberal discount.

The most complete "A" Power Kit ever offered—Address for details of plan—

David W. Knapp, Pres.

Knapp Electric, Inc., Room 414
350 Madison Ave., New York City

HOOK-UP BOOK FREE

Improve your reception with CARBORUNDUM Stabilizing Detector Units, Grid Leaks and Resistors

THE CARBORUNDUM COMPANY
DEPT. D-2, NIAGARA FALLS, N. Y.



Letters from Readers

(Continued from page 137)

reasons I am a subscriber to RADIO BROADCAST is because of its clear, complete, concise articles of real developments in radio backed by a fearless conservative editorial policy.

H. H. HORNING, Pottsville, Pa.

To the Editor:

I wish to express my earnest appreciation of your new feature, the "Home-Study Sheets." The neatness with which they are printed and the useful information they contain are certainly a great aid to your publication. What we want is experimental and physics side of radio, not the program discussion side.

VINCENT V. GARZIA, JR., Elmhurst, L. I.

The Sea-Going Tube Again

SOME time ago we published an interesting account of the travels of a sea-going vacuum tube. The article, it will be remembered, stated that the vacuum tube passed from one ocean to the other through the Panama Canal, which resulted in considerable discussion among our readers. In this department in our August issue R. S. Fulton, radio operator on the S. S. *Hechelega*, tried to show how it would be impossible for a small object to pass through the Canal. Now we print another letter which takes the affirmative side of the controversy. You take your choice!

To the Editor:

It is quite possible for any small article to pass from one ocean to the other through the Canal, as I shall endeavor to demonstrate. A vessel in passing from the Atlantic to the Pacific approaches and enters the lock at sea level, floating in salt water. The gates are closed behind her, water from the lake is allowed to enter the lock until the vessel has been raised to the level of the lake. Any small article, such as a vacuum tube, which happened to be near the outer gates of the lock at the time the vessel entered would be drawn along into the lock by the slight following current always created by the movement of a vessel, and would be raised to the lake level along with the vessel, and likewise probably would be drawn along with her into the lake when the inner gates were opened for her passage.

Once in the lake, the tube's course would be determined by the number of vessels passing through the canal. If south-bound vessels predominated, the currents in the lake would be stronger in the direction of the locks on the Pacific side, whereas if more north-bound vessels passed through, the tube probably would be carried out to the Atlantic again, through the lock through which it entered. Of course, most of the water used in raising and lowering vessels in the locks comes from the lake, but every time a vessel passes from sea level to lake level some sea water enters the lake. If Mr. Fulton doubts this let him taste the water in Gatun Lake, which is fed by fresh-water streams, and he will find that it has a distinct brackish flavor, due to the sea water entering through the locks. It is almost a case of water flowing up hill.

E. D. PREY, Ellendale, Del.

Short-Wave Hints from the Tropics

To the Editor:

As a point of interest to short-wave receiver constructors, the following data has been used in avoiding the usual obstreperous "body capacity" found in most regenerative short-wave receivers. When building, use a heavy metal sub-panel bracket—or rather, a pair of them. Use the positive or negative filament to "ground them out," and the body capacity becomes a thing of the past as far as causing the set to go into oscillation is concerned. This point has made the building of short-wave receivers in this part of the Americas a success where otherwise it was a failure. For all-year reception, short waves are the only answer here. The standard receiver is a

(Concluded on page 141)

Radio Will Be Different in 1929

The Only Handbook Prepared for the Change Is

THE RADIO MANUAL



Here is the most complete, most up-to-date handbook in the radio field. It deals with every problem of principle, method, or apparatus involved in radio transmitting and receiving. It meets every need of student, amateur, operator and inspector. It presents in a single volume, a complete course in radio operation developed simply and clearly, yet in complete technical detail. The beginner with no knowledge of electricity will find all he needs either for amateur operation or to qualify for government license. The professional operator or inspector will use it as a daily reference guide.

A Wealth of Information Never Before Made Available

The accepted practise as adopted by the International Radio Telegraphic Convention effective January 1, 1928, is completely recorded—the New International "Q" signals; procedure for obtaining a radio compass bearing; procedure when SOS call is transmitted or when the spoken expression *Mayday* is heard from a radio telephone station; etc., etc. There is also presented for the first time a complete description of the Western Electric 5 Kilowatt Broadcasting Transmitter; description and circuit diagram of Western Electric Superheterodyne Radio Receiving Outfit type 6004-C; Navy standard 2-Kilowatt Spark Transmitter, etc., etc. Every detail up to the minute.

Prepared by Official Examining Officer

The author, G. E. STERLING, is Radio Inspector and Examining Officer, Radio Division, U. S. Dept. of Commerce. The book has been edited in detail by ROBERT S. KRUSE, for five years Technical Editor of QST, the Magazine of the Radio Relay League. Many other experts assisted them.

Special subjects such as Radio Control operating have been contributed to by Carl Dreher of the National Broadcasting Co., and the treatment of the stabilization of radio frequency amplifiers is by Dr. Lewis M. Hull, the well-known authority.

The Whole Subject in One Volume

Never before has so complete a treatment of radio theory and operation been compressed into a single volume. Here is information that otherwise you could secure only by consulting many different books. And every detail is vouched for by authorities of the first rank. The Manual is profusely illustrated with photographs and diagrams. There are 700 pages, bound in flexible fabricoid that is extremely durable. The immediate demand for so valuable a handbook has already nearly exhausted the second large edition. To be sure of receiving your copy without delay, order at once.

FREE EXAMINATION

Use This Coupon

D. VAN NOSTRAND CO., Inc., 8 Warren St., New York

Send me THE RADIO MANUAL for examination. Within ten days after receipt I will either return the volume or send you \$6.00—the price in full. (Radio Broadcast 12-78)

Name.....
 St. & No.....
 City and State.....

Set Builders Circuit Designers Radio Engineers

Here is a
Book
You Need!



Send for it Today



When the leading set manufacturers of the country choose Yaxley parts there is something more than even an outstanding reputation at work.

Yaxley parts are used in vital places; if they were not entirely dependable, these set manufacturers would not stake trade and customer satisfaction on their performance.



Yaxley Mfg. Co.
Dept. B, 9 So. Clinton St.
Chicago, Ill.

LAYING THE CORNERSTONE OF QUALITY

Polymet condensers and resistances for Radio and Television are carefully made—carefully tested, and accurately rated—is it any wonder they are the choice of 2/3 of the R. C. A. licensed manufacturers.

Send for the Polymet Catalogue
POLYMET MANUFACTURING CORP.
597 Broadway New York City



POLYMET PRODUCTS



An Amateur Set Builder Says

"As an amateur who has built quite a number of sets, I can honestly say that Braidite is the fastest and easiest hook-up wire to work with and it also makes the neatest and most workman-like looking job. I like the way the insulation on Braidite slides right back into place after making a connection, thus leaving no exposed sections of bare wire."

At All Dealers

25 Feet Stranded..... 35c
25 Feet Solid..... 30c
Red, Green, Yellow, Blue, Black

FREE Send us the name and address of your dealer and we will send you a sample package of Braidite FREE. Include 10c for postage.

CORNISH WIRE CO.
38 Church Street New York City

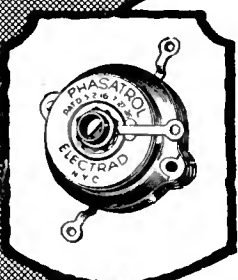

Licensed by Rider Radio Corporation. Patented 5-2-18; 7-27-26. Pats. Pending

Suppress Oscillations PHASATROL

A True Balancing Device for Radio Frequency Amplifiers

PHASATROL is an unusually efficient device for controlling radio frequency oscillations and thus eliminating the disturbances to reception which they cause. Adapted to any type of receiver using R.F. amplification. A wonderful improvement for the new A.C. circuits where the elimination of noise is often a problem. Price, \$2.75 each.

Electrad specializes in a full line of Controls for all Radio Purposes including Television.

Write for Free Hook-up Circulars and Full Information

Dept. M-12, 175 Varick Street
New York

ELECTRAD



TRUE TONAL VALUES

de Forest AUDIONS

FOR those who appreciate better radio reception, the new, perfected De Forest Audions—the latest achievement of Dr. Lee De Forest—assure the true tonal values of reproduction which add so much to radio enjoyment.

Sold by leading dealers everywhere

DE FOREST RADIO CO.
Jersey City, New Jersey



DE FOREST AUDIONS

Letters from Readers

(Continued from page 139)

5-tube, push-pull outfit, using two straight 6:1 stages of audio, followed by push-pull.

Incidentally, as a matter of information, for use in the tropics the Samson transformer is the only 100 percenter we have found in the commercial type to withstand humidity, etc. This is a tip for any jungle parties or other expeditions expecting to use States' constructed receivers in this territory. Of the commercial sets Atwater Kent's special Tropical Model receiver is the only one to meet with existing conditions in the tropics.

L. C. LEIGHTON,
Cristobal, Canal Zone.

Advertising Circulars

OUR contributor Robert S. Kruse has been an amateur for a number of years and, as a result, his name and address have been listed in many radio call books. Persons whose hobby is made public in this manner always receive a great deal of advertising in their mail, and this is often considered an annoyance, particularly when two or three circulars on the same subject are received. Judging from his letter, Mr. Kruse is evidently the victim of considerable high-powered publicity of this sort.

To the Editor:

It is possible to do the industry a service by stating publicly that the mailing list of radio amateurs employed by several prominent New York mailing firms is of the same vintage as the water that floated the ark. Advertisers are paying good money to have circular matter sent to stations that were dead three years ago. I, for instance, am constantly receiving such matter addressed to a station at Silver Lane, Conn., which has not existed for four years, and one at Washington, D. C., which has been dead for eight years, and even one at Lawrence, Kansas, which took out its last license in 1914!

ROBERT S. KRUSE, West Hartford, Conn.

Short Wave Stations

MANY radio listeners equipped with short-wave receivers are anxious to pick up the signals of experimental telephone stations operating on frequencies within the range of their set. In this connection RADIO BROADCAST has endeavored to prepare a schedule of short-wave transmissions, but it has been found that the hours of operation of these stations is varied from day to day. The list which is printed below contains as much accurate data as it is possible to publish at the present time. The principal stations of the world, which may be heard regularly in this country with a simple short-wave receiver, are listed in the order of their assigned wavelengths.

Call Letters	Location	Wave Length
AGC	Nauen, Germany	17.2
PCLL	Kootwijk, Holland	18.0
WOWO	Fort Wayne	22.8
5SW	Chelmsford, England	24.0
2XAB	New York	24.0
2FC	Sydney, Australia	28.5
2ME	Sydney, Australia	28.5
PCJJ	Hilversum, Holland	30.2
3XAL	New York	30.9t
2XAF	Schenectady	32.7
JB	Johannesburg, S. Africa	32.0
PCLL	Kootwijk, Holland	32.0
6AXR	San Francisco	33.0
3LO	Melbourne, Australia	32.0
2XA1	Newark	43.0
WBZ	Springfield	50.0
WTFF	Mt. Vernon, Va.	56.0
AJG	Nauen, Germany	56.7
WLW	Cincinnati	52.02
2XE	Richmond Hill	21.1
GC	Paris, France	60.0
3XL	Bound Brook	60.0
9XU	Council Bluffs	61.06
KDKA	Pittsburgh	62.5
2XBA	Newark	65.18
WBZ	Springfield	70.0

HAVE YOU HEARD IT?

New 1929

Browning-Drake

EIGHT-IN-LINE

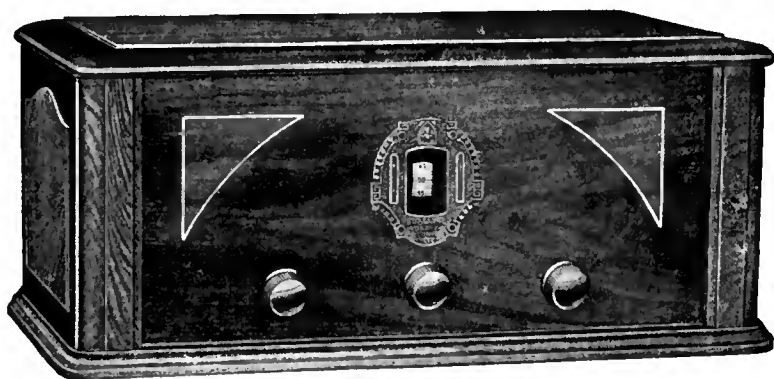

Eight tubes in line—aluminum construction throughout—all power equipment an integral part of chassis—this year's masterpiece of mechanical construction.

Browning-Drake dealers know the value of tonal perfection, and what it means to their customers. Listen to a 1929 type receiver and understand why there are a million Browning-Drake fans.

BROWNING-DRAKE CORPORATION
Cambridge, Mass.

BROWNING-DRAKE
RADIO

BOOKS

in a minute

by TELEGRAPH

DOUBLEDAY, DORAN BOOK SHOPS

New York Newark Toledo
Kansas City Cleveland St. Louis

**More "A" Power
For Less Money!**

With the Set Builders discount card you can purchase a

KNAPP "A" POWER KIT
at a liberal discount.

Write me today for full details telling about this new money-saving plan for set builders.

DAVID W. KNAPP, Pres.

Knapp Electric, Inc. Room 414
Division of P. R. Mallory & Co., Inc.
350 Madison Ave. New York

AT LAST!

Matched Tubes

the Only Assurance of Maximum Efficiency and 100% Satisfaction from any Tuned Radio Frequency or Super Heterodyne Circuit.

This is the first time matched sets of Cunningham or R. C. A. tubes have been offered at list price. Tested and matched seven ways on our specially designed testing panels. All tubes plainly marked with characteristics.

Order today. Pay the postman the list price plus 5c each for packing and shipping.

LIST PRICE

112A	\$2.75	\$10	\$9.00
120	2.50	\$22	6.50
171A	2.75	\$26	2.25
190	2.25	\$27	4.00
200A	1.00	\$40	2.00
201A	1.50		

H. M. HEWSON, Merion, Pa.

Compensating

AUDIO TRANSFORMER

Brings Out the LOST NOTES In Any Receiver



ANY radio set can be improved from 25 to 100% in tone range. That is a flat, simple, direct statement from Remler—a firm famous for ten years of radio reliability.

The new Compensating Transformer, No. 905, replaces the first audio transformer in your receiver. This easy change is quickly made—and results are amazing. Especially when used with a dynamic speaker, the new Compensating Transformer proves its worth by delivering energy over the complete range of the speaker. Use it to get the most out of your Dynamic Cone. Not an experiment—proved and tested in every popular set and circuit. A special pressed-steel demonstrating base makes it easy for the dealer or set-builder to demonstrate the difference to clients. Sign the coupon for full details.

Remler Division, Gray & Danielson Mfg. Co.
260 First Street, San Francisco, California.

Gentlemen: Please send me complete information on

New Compensating Transformer.
 Demonstrating Base.

Name

Address

City.....State.....R. B. 12

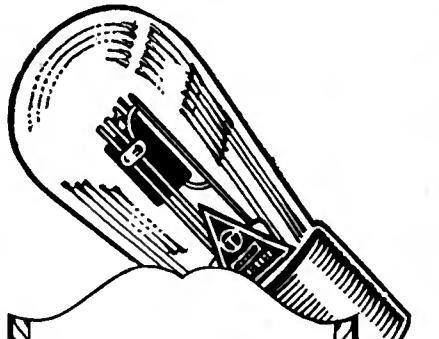

The only tubes with the exclusive Televocal Support which eliminates microphonic noises. Made in all standard types. Ask for them at your dealers.

Televocal Corporation
Televocal Building
Dept. B-5, 588 12th Street
West New York, N. J.

Televocal

Quality Tubes

Potter Condensers

**Quality
Long Life
Uniformity
Economy**



Leading manufacturers have selected Potter Condensers for the finest radio sets. Why not follow their good judgment.

Insure the operation of your radio set and power amplifier with the use of this high grade product.

Potter T-2900 Condenser Block for the single 250 type tube amplifier—\$20.00.

Potter T-2950 Condenser Block for the push-pull 250 type tube amplifier—\$22.50.

Potter By-Pass and Filter Condensers are available in all capacities and working voltages.



POTTER Interference Eliminator

Your radio broadcast programs need no longer be spoiled by interference from oil burners, ice machine motors, vacuum cleaners, violet rays, etc.

The remedy is to connect a Potter Interference Eliminator to the interfering device.

Potter Manufacturing Co.
North Chicago, Ill.
A National Organization at Your Service

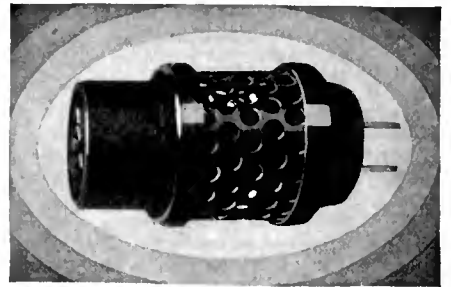

\$2.00 Insures Your A.C. Tubes

The Vitrohm 507-109 Unit costs \$2.00. Installed on your radio set, it lengthens a. c. tube life by automatically lowering filament voltage.

Attached in a moment—Nothing combustible—Nothing to wear out—Does not get excessively hot.

It consists of a Vitrohm Resistor mounted within a perforated metal cage, a plug, and a receptacle.

*Write for free information on this and other Ward Leonard Radio Products.

WARD LEONARD MOUNT VERNON ELECTRIC CO. NEW YORK

Write for this Discount Card NOW!

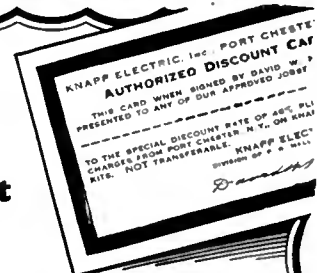

It will enable you to purchase the New and Improved

KNAPP "A" POWER KIT
at a liberal discount

The new Knapp "A" is the finest and most complete kit ever offered. It is the only "A" Power adaptable to Short Wave—Super Heterodyne and Television reception.

Take advantage of the wonderful offer today—write

David W. Knapp, Pres.

Knapp Electric, Inc.

Division of P. R. Mallory & Co., Inc.

Room 414, 350 Madison Ave., N. Y. City

NEWS to Set Builders

LATEST RADIO GUIDE

Barawik offers set builders bigger bargains—bigger opportunities to make money this season. New sets, new kit ideas, all the leading parts, dynamic speakers, supplies, etc. Lowest rock-bottom prices. Bigger stocks, quicker service. Send for Big Bargain Book today—free.

BARAWIK CO., CHICAGO, U.S.A.

ROBERT S. KRUSE
Consultant and Technical Writer

103 Meadowbrook Road, West Hartford, Conn.
Telephone Hartford 45327

Until you have heard the NEW VICTOREEN "A.C." or "D.C."

You cannot realize the marvelous development in Radio Reception

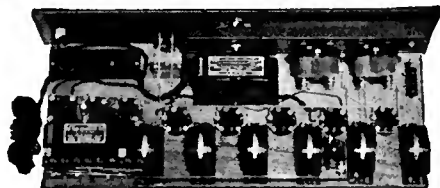

The new Victoreen is simply wonderful—that is the only way to describe it. It has *wonderful* tone—wonderful selectivity, *wonderful* sensitivity. It is wonderfully simple to assemble, wonderfully easy to operate. Anyone who has the slightest "knack" can assemble in a few pleasant hours a set which, from every standpoint, simply cannot be surpassed.

This is a season of wonderful radio programs. With a Victoreen you can enjoy them from coast to coast. If a Victoreen can't get a station it can't be had.

Victoreen R. F. Transformers have been greatly improved—the circuit has been still further developed—many other radical improvements have been made which make Victoreen more than ever, the world's standard "Super."

Write for complete Victoreen story and the *FREE Blue Print* giving constructional data and full directions. You'll have a set that you can boast about, when you have a Victoreen.

The Blue Print is FREE

**Victoreen Power Amplifier
and "B" Supply**
makes any good set better

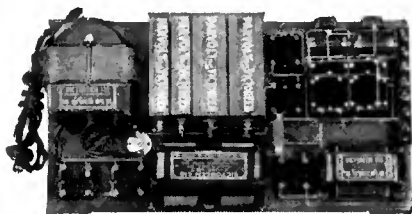

Supplies 45, 90, 180, and 450 volts, using a UX210 or 250 in the last stage. Contains two voltage regulator tubes so that the 90 and 180 volt taps are supplied with a constant volt potential. It is the last word in "B" Supply. For the most satisfactory results you **MUST** have it.

FREE BLUE PRINT with list of parts and complete assembly instructions, will be sent upon request.

The Geo. W. Walker Company
Merchandisers of Victoreen Radio Products
2825 Chester Ave., Cleveland, Ohio

Victoreen



Push-Pull Power Stage for Dynamic Speakers

For best results, every dynamic type speaker should be preceded by a push-pull amplifier. This is particularly true because they reproduce frequencies as low as 30 cycles and the attendant hum from raw AC on the filaments of power tubes is greatly pronounced unless filtered out by a push-pull amplifier.

The AmerTran completely wired push-pull power stage has been specially designed for dynamic speakers. Consists of type 151 input and output transformers (200 for working out of 210 type tubes or type 362 for 171 type tubes). Both the 200 and the 362 have the secondary designed for connecting directly to the moving coil of the speakers. Completely wired with sockets and resistances. Also available for cone type speakers and for both 210 and 171 tubes.

Licensed under patents owned or controlled by RCA and may be bought with tubes.

Price complete (without tubes) \$36.00
(slightly higher west of Rocky Mountains)

Write us for hook-up of this remarkable instrument.

AMERICAN TRANSFORMER CO.

Transformer Builders for more than 28 years

287 Emmet Street

Newark, N. J.

POWER TRANSFORMERS

For the UX250 Power Tube

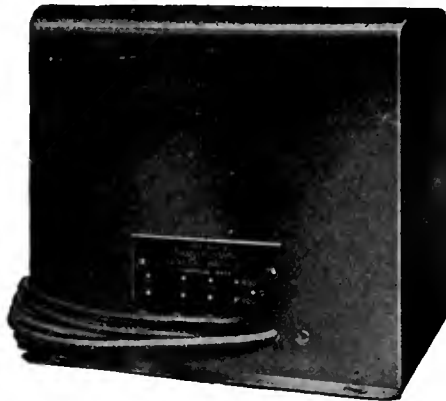

Type 565-B Transformer
(200 Watts)

Price - - - - \$13.50

Bulletin No. 931 will be
sent on request

The success of a high-quality amplifier depends largely on the power supply. The General Radio Type 565 Power Transformers are especially designed for use in plate-supply units intended for the 250 type of power tube. The type 565-B Transformer illustrated consists of a center-tapped 1,200 volt secondary and two 7.5 volt secondaries. It is designed for 105 to 125-volt, 50 to 60-cycle lines.

GENERAL RADIO COMPANY

30 State St. Cambridge, Mass.
274 Brannan St., San Francisco, Cal.

first time offered

16⁵⁰
Complete with 5 coils

Shielded SHORT WAVE CONVERTER

The Only Unit With a Wave Length Range of 15 to 550 Meters

Introducing another triumph for SHORT WAVE reception. Highest efficiency at an amazingly low price, made possible by economic production. Now, all can afford to get the best entertainment of the air being broadcast on short waves by many powerful stations throughout the U. S. and Europe.

EASY TO ATTACH AND OPERATE
The new model, Dresner Shielded Short Wave Converter is completely assembled, and may be used on any set. It is built in a beautiful mahogany finished metal cabinet. Efficiently covers a wave band of 15 to 550 meters.

GUARANTEED to give you highest satisfaction. Take advantage of this special offer at once. If your dealer cannot supply you, SEND MONEY ORDER DIRECT and we will ship at once.
(When ordering unit, be sure to specify whether it is to be used on AC or DC set).

Dresner Radio Manufacturing Corp.
640 Southern Boulevard Dept. A-12
New York, N. Y.

Remarkably Low Price

SET BUILDERS
write for
Discount Card

Enabling you to purchase the new and Improved Knapp "A" Power Kit at big discount—Write for full particulars.

DAVID W. KNAPP, Pres.
Knapp Electric, Inc.
Division of P. R. Mallory & Co. Inc.
Room 414, 350 Madison Ave., N. Y. C.

CUSTOM SET BUILDERS

Browning-Drake has an interesting and unusual proposition. Take advantage of the fact that more Browning-Drakes are built than any other. Write today.

BROWNING-DRAKE CORP.
Cambridge Massachusetts

MIDGET TELEPLEX

CODE SENDER
ONLY \$3⁵⁰ Post-paid
Guaranteed

Why not subscribe to *Radio Broadcast*? By the year only \$4.00; or two years \$6.00, saving \$2.00. Send direct to Doubleday, Doran & Co., Inc., Garden City, New York.

Send for **WESTERN RADIO**

New 1929 Catalog

DEALERS AND SET BUILDERS
The NEW 1929 catalog is crammed full of the FINEST, NEWEST. Nationally known A. C. sets, consoles, cabinets, dynamic speakers, kits, eliminators and accessories at **LOWEST PRICES**. Largest stock of radio parts Prompt delivery. No delay.

Write for our **FREE** catalog
WESTERN RADIO MANUFACTURING CO.
128 W. Lake St. Dept. RB-12 Chicago

FREE ACWESTRAD Tube \$4.95

WESTERN RADIO

The Big Friendly Radio House

Be An **Expert RADIO OPERATOR!** Travel. Adventure. Good pay. This amazing instrument teaches you to read code in half the usual time. Reproduces actual sending of expert operators. Sends you messages, radiograms, etc., anywhere, any time, any speed. You'll be amazed when you hear it. Just like having an expert operator in your home. Code lessons recorded on strong, waxed-tape records make everything simple and clear. Send only \$3.50 for Midget Teleplex with lessons; or \$5.50 complete with high-frequency key and buzzer. Satisfaction guaranteed. Money back if not delighted. Send today.

TELEPLEX CO., 72 Cortlandt St., New York, N. Y.

Books by Telegraph between

New York
Atlantic City
Chicago
St. Louis
Kansas City
Cleveland
Springfield

Doubleday, Doran Book Shop



TELEVISION
simplified!

CONTROLLING the receiver scanning disk—that's the big problem in television. Yet there is nothing to it when you have the

SPEED CONTROL CLAROSTAT

REG. U. S. PAT. OFF.

You can bring the scanning disk to speed and hold the image on the screen as easily as you steer your car.

A handsome and useful device, this SPEED CONTROL CLAROSTAT. Controls any variable speed motor of 1/2 h.p. or less, from standstill to practically full speed in several turns of knob. Push button for quick starts and for momentary acceleration. Heavy metal case. Properly ventilated. Protected screw terminals. 25 to 500 ohm resistance range. 80-watt rating. Readily mounted. Convenient. *And it sells for \$5.00.*

Ideal for television. *But that's only half the story.* The SPEED CONTROL CLAROSTAT has no end of applications in radio and electrical work where a variable or fixed heavy-duty resistance is required.

WRITE for literature regarding the SPEED CONTROL CLAROSTAT as well as other Clarostats for every radio purpose. Better still, send 25c for "The Gateway to Better Radio"—the best investment you ever made in radio.

CLAROSTAT MFG. CO., Inc.
285 N. 6th Street, BROOKLYN, N. Y.

Now...4 or 6 Volts
with the
Improved
Knapp
"A" POWER



Operates on 105 to 120 volts, 50 to 60 cycles.

10
Improvements

1. Two taps for 4 or 6 volts operation.
2. Larger filter system.
3. Three Elkon Dry Condensers instead of two.
4. Improved Choke Coils.
5. Pentod Switch, Controlling "A" Power, "B" Eliminator and Set.
6. Dial for Regulating Voltage.
7. Celeron Front Panel.
8. Baked Finish.
9. Heavier Gauge Metal Cover.
10. Die Cast Base Plate instead of wood.

The only "A" Power
Suitable for all Sets

— Irrespective of number of tubes — including
SuperHets, Short Wave and Television receivers

THE new Knapp "A" Power is designed for the most exacting service — super-hets, short wave and television receivers included. I knew that if it would perform satisfactorily with these receivers that there could be no question as to its efficiency on ordinary broadcast signals. The three Elkon dry condensers, the improved choke coils and the *special* Elkon dry rectifier make the difference between ordinary and Knapp performance.

No Change in Price

Even with these wonderful and costly improvements, there has been no advance in price—due to the tremendous volume going thru my plant. Remember that the Knapp is the fastest selling "A" Power on the market.



David W. Knapp, Pres.

KNAPP ELECTRIC, Inc.
—Division of P. R. Mallory & Co., Inc.—
350 Madison Ave., New York City

See your dealer today

Go to your dealer today. Most of the good ones carry the Knapp in stock. Do not accept a substitute—because only in the Knapp will you get full satisfaction as typified by the famous Knapp "A" Power. If your dealer cannot supply you send the coupon.

Mr. David W. Knapp, Pres.,
Knapp Electric, Inc., Dept. K-21
350 Madison Ave., N. Y. C.
Send me complete information on the Knapp
"A" Power.

FERRANTI
Audio Frequency
Transformers



are specified for the
SKYSCRAPER

A remarkable radio receiver using two 222 type tubes in the radio stages. A real engineering job with unusually high gain and selectivity. Tone quality unsurpassed.

Complete instructions for building the Skyscraper will be sent for \$1.00 net.

Send 15c in coin for copy of the 1929 Ferranti Year Book

FERRANTI, INC.
130 W. 42nd St. New York, N. Y.
FERRANTI, Ltd. FERRANTI
Hollinwood ELECTRIC, Ltd.
England Toronto, Canada



**SOCKETS—
PICKUP—
ADAPTERS**

No. 426
50c



Two outstanding NA-ALD products. Above—The No. 426 Socket at 50 cents is one of a family of fourteen stationary and spring mounted sockets designed for every purpose. Note the copyrighted colored locator ring. It is an exclusive NA-ALD feature. Below—The NA-ALD Electric Pickup priced so every radio set owner can enjoy the wonderful tone quality of music electrically amplified from any phonograph through their radio set or power amplifier. **GET YOURS TODAY. TRY IT FOR THREE DAYS** and if not satisfied your money will be refunded.



No. 502
**ELECTRIC
PICKUP
ONLY**
\$5.00

Please send me. Send C. O. D.
 One Electric Pickup. \$5.00 Enclosed.
 Complete Naald Catalog—FREE.

Name

St. and No.

City and State

ALDEN MANUFACTURING CO.
Dept. R. B. 5 Brockton, Mass.

**GET MY
DISCOUNT CARD!**

**Before buying a
KNAPP "A" POWER KIT**

Absolutely dry—Magically
silent—the finest "A" Power
adaptable to Short Wave,
Super-Heterodyne and Tele-
vision reception.

**WITH THE
10 NEW IMPROVEMENTS**

Write me today for details of this
money saving plan and get your dis-
count card. Address

DAVID W. KNAPP, Pres.
Knapp Electric, Inc.
Division of P. R. Mallory & Co., Inc.
Room 414, 350 Madison Ave., N.Y.C.

**WRITE
TODAY**

Send for large, new, il-
lustrated Catalog "A-3,"
showing the latest of
everything in radio at
wholesale prices.

**Allied Radio
CORPORATION**
711 W. LAKE STREET, CHICAGO

GENUINE
**Nathaniel
BALDWIN** Regular
\$9.00
Famous Type C



HEADPHONES

We offer several thousand genuine Nathaniel Baldwin Perfect Type C headphones fresh from the factory in original sealed cartons at a fraction of their cost. Never before sold for less than \$9. Price while they last only \$5.50. Satisfaction guaranteed or money refunded.

BALDWIN HEADPHONES
hold all long distance records, you simply cannot get distance by any other means. An operator at San Francisco picked up a code message from Bagdad, Turkey, half way around the globe, a world's record. Whether you are a professional operator, amateur, experimenter, set builder or B. C. L. these are the headphones you need.

PREMIER ELECTRIC CO.
138-135 West 21st St., New York

**OUR
PRICE
\$5.50**

**ORDER
NOW**



Zeh Bouck
says:

"MORECROFT is the finest engineering interpretation of Radio's first quarter century we have."

John H. Morecroft
Second Edition—Revised and Enlarged

**Principles of Radio
Communication**

BY JOHN H. MORECROFT

Again Mr. Bouck says: "No radio book has ever been of greater utility to the engineer and student than this classic—the only reliable reference of its kind six years ago and today the most astounding collection of answers to technical questions from the analysis of radio frequency phenomena in terms of complex formulae to why a particular amplifier howls."

\$7.50

JOHN WILEY & SONS, Inc.
440 Fourth Ave., New York

Please send me Morecroft's RADIO COMMUNICATION for free examination. Within ten days after its receipt, I will either return the book or send you \$7.50.

Name

Address

Firm

RB 12-28

Radio
Dealers ...

Send us your order for
copies of

Radio Broadcast's
Data Sheets

Retail, \$1.00
Liberal Trade Discount

Prompt deliveries in any quantity
from stock on hand at the office of
your local News Company.

American News Company
131 Varick Street
New York

STATEMENT OF THE OWNERSHIP, MANAGEMENT, CIRCULATION, ETC., required by the Act of Congress of August 24, 1912, of RADIO BROADCAST, published monthly at Garden City, New York for October 1, 1928. State of New York, County of Nassau.

Before me, a Notary Public in and for the State and County aforesaid, personally appeared John J. Hessian, who, having been duly sworn, according to law, deposes and says that he is the treasurer of Doubleday, Doran & Co., Inc., owners of Radio Broadcast and that the following is, to the best of his knowledge and belief, a true statement of the ownership, management (and if a daily paper, the circulation), etc., of the aforesaid publication for the date shown in the above caption, required by the Act of August 24, 1912, embodied in section 411, Postal Laws and Regulations, printed on the reverse of this form, to wit:

- That the names and addresses of the publisher, editor, managing editor, and business managers are: *Publisher*, Doubleday, Doran & Co., Inc., Garden City, N. Y.; *Editor*, Willis Wing, Garden City, N. Y.; *Business Managers*, Doubleday, Doran & Co., Inc. Garden City, N. Y.
- That the owner is: (If owned by a corporation, its name and address must be stated and also immediately thereunder the names and addresses of stockholders owning or holding one per cent. or more of total amount of stock. If not owned by a corporation, the names and addresses of the individual owners must be given. If owned by a firm, company, or other unincorporated concern, its name and address, as well as those of each individual member, must be given.) F. N. Doubleday, Garden City, N. Y.; Nelson Doubleday, Garden City, N. Y.; S. A. Everitt, Garden City, N. Y.; Russell Doubleday, Garden City, N. Y.; George H. Doran, 244 Madison Avenue, N. Y. C.; George H. Doran, Trustee for M. N. Doran, 244 Madison Avenue, N. Y. C.; John J. Hessian, Garden City, N. Y.; Dorothy D. Babcock, Oyster Bay, N. Y.; Alice De Graff, Oyster Bay, N. Y.; Florence Van Wyck Doubleday, Oyster Bay, N. Y.; F. N. Doubleday or Russell Doubleday, Trustee for Florence Doubleday, Garden City, N. Y.; Janet Doubleday, Glen Cove, N. Y.; W. Herbert Eaton, Garden City, N. Y.; S. A. Everitt or John J. Hessian, Trustee for Josephine Everitt, Garden City, N. Y.; William J. Neal, Garden City, N. Y.; Daniel W. Nye, Garden City, N. Y.; E. French Strother, Garden City, N. Y.; Henry L. Jones, 244 Madison Ave., N. Y. C.; W. J. Etherington, 50 East 42nd St., N. Y. C.; Stanley M. Rinehart, Jr., 1192 Park Ave., N. Y. C.
- That the known bondholders, mortgagees, and other security holders owning or holding 1 per cent. or more of total amount of bonds, mortgages, or other securities are: (If there are none, so state.) NONE.
- That the two paragraphs next above, giving the names of the owners, stockholders, and security holders, if any, contain not only the list of stockholders and security holders as they appear upon the books of the company but also, in cases where the stockholder or security holder appears upon the books of the company as trustee or in any other fiduciary relation, the name of the person or corporation for whom such trustee is acting, is given; also that the said two paragraphs contain statements embracing affiant's full knowledge and belief as to the circumstances and conditions under which stockholders and security holders who do not appear upon the books of the company as trustees, hold stock and securities in a capacity other than that of a bona fide owner; and this affiant has no reason to believe that any other person, association, or corporation has any interest direct or indirect in the said stock, bonds, or other securities than as so stated by him.
- That the average number of copies of each issue of this publication sold or distributed, through the mails or otherwise, to paid subscribers during the six months preceding the date shown above is..... (This information is required from daily publications only.)
(Signed) DOUBLEDAY, DORAN & COMPANY, Inc.
By John J. Hessian, *Treasurer*.

Sworn to and subscribed before me this 7th day of September, 1928.

[SEAL] (Signed) Frank O'Sullivan
Notary Public Queens County No. 1501
Certificate filed in Nassau County
Term expires March 30, 1930

SM

This Is the Type of Kit that **GRAYMORE** Heartily Recommends and Can Ship from Stock

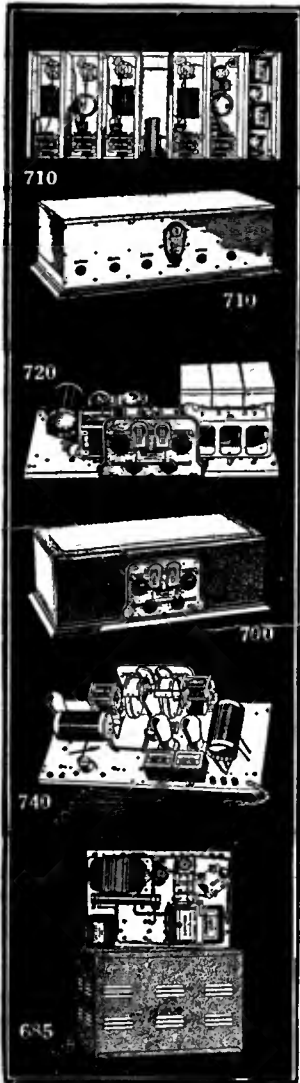

710 Sargent-Rayment Seven
Designed by two famous engineers to give the very extreme of results now possible in broadcast reception, irrespective of cost, the S-M 710 Sargent-Rayment Seven sets an entirely new standard. Exhausting the tremendous distance possibilities of 4-screen-grid R.F. stages—bringing in a station on every 10-kilocycle channel right around its single-control dial (with five auxiliary vernier knobs)—equipped with the unequalled S-M Clough system audio amplifier—yet the 710 is only \$175 custom-built complete, or \$130 for kit including aluminum cabinet.

720 Screen Grid Six
The new S-M 720 embodies in the most perfect form the revolution that screen-grid tubes have brought about in long-distance reception. Three of these tubes in the R.F. stages, with shielded S-M coils, bring in distant stations on the next 10 kc. channel to powerful locals! The new S-M 255 and 256 transformers set a far higher standard of tone quality than ever known before. Custom-built complete in 700 cabinet, \$102.00; complete kit, with pierced metal chassis and antique brass escutcheon but without cabinet, \$72.50.

700 Shielding Cabinet
Beautiful two-tone brown moire finish, with walnut finish wood base, \$9.25.

740 Coast-to-Coast Four
A time-tested and famous circuit—one R.F. stage, regenerative detector (non-radiating) and two A.F. stages—combined with immeasurably finer coils, the high efficiency of the screen-grid tube, all the gain of smooth-working regeneration, and new S-M Clough-system audios, make the 740 the greatest value in the fifty-dollar class. WIRED in 700 cabinet: 740 (for D.C. tubes) \$75; 740AC (A.C. tubes) \$78. Kit less cabinet: 740, \$51; 740AC, \$53.

680 Series Unipacs
Perfect reproduction and hum-free light-socket operation have made S-M Unipacs famous. There are four types: two single-stage, and two two-stage models, using 210 or 250 tubes singly and in push-pull. Unipacs are available in kit or wired form—some supplying ABC power to receiver—at \$81.50 to \$117. Also 685 Public-Address—WIRED, \$160; KIT, \$125.

Round-the-World Short Wave Sets

--and that means exactly what it says. As for instance:

**RADIO STATION
CFBO
SAINT JOHN, N. B.
CANADA**

Silver-Marshall Inc., Chicago, Ill.

Dear Sirs:—

About two months ago I purchased one of your Round the World Four Short Wave Kits . . .

The first day I had it was on a Sunday and from 12 Noon our time until 12 Midnight I never was without music. This set brought in KDKA, WGY, 5SW Chelmsford England and PCCJ Holland all with Loud Speaker Volume and good modulation.

Since then I have used same in St. John here for rebroadcasting thru our station CFBO.

As I am writing this only to-day I have been able to bring the first two Worlds Series Baseball games and rebroadcast them complete from start to finish.

Please remember that we do not get any daylight reception here at all from either U.S. or Canadian Stations on the B.C.L. band, 200 to 600 Meters.

In closing I can only say that I built over twelve different short wave sets and yet to find the equal of the Round the World Four. 5SW comes in every evening and 50% of the time with loud speaker volume.

Yours very truly
F. D. Thorne
Supt. C F B O

S-M "Round-the-World" Sets Are Available as Follows

COMPLETE KIT

Everything necessary to build the complete four tube r.f. regenerative (non-radiating) short-wave set, including aluminum cabinet and two S-M Clough audio transformers.
730 Complete Kit.....\$51.00 730 Set, Wired.....\$66.00

ADAPTER KIT

Complete with aluminum cabinet, less the two audio stages. Used with an adapter plug, it converts any broadcast receiver for short-wave use. Ideal for Television.
731 Adapter Kit.....\$36.00 731 Adapter, Wired.....\$46.00

ESSENTIAL KIT

Contains the two tuning and tickler condensers, four wound plug-in coils, coil socket, and three r.f. chokes, with full instructions for building a 1, 2, 3, or 4 tube set.
732 Essential Kit.....\$16.50

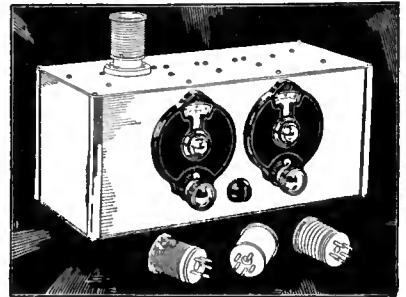

Headquarters for S-M Parts and Kits

WE are one of Silver-Marshall's largest jobbers, and can fill promptly your mail orders for S-M, as well as for other high quality merchandise. Send coupon for our new catalog. Best discounts to dealers.

Graymore Radio Corporation

142 Liberty St.

New York, N. Y.

Prompt shipments on all items of the S-M line, including the new 678PD Phonograph Amplifier and power supplies and transformers of all types.

GRAYMORE RADIO CORP. RB1
142 Liberty St., New York, N. Y.

Please send your big new catalog of highest-quality radio parts and kits.

Name.....

Address.....

Town.....State.....